

2002-2003



**HONDA**

**SERVICE MANUAL**

**CR250R**

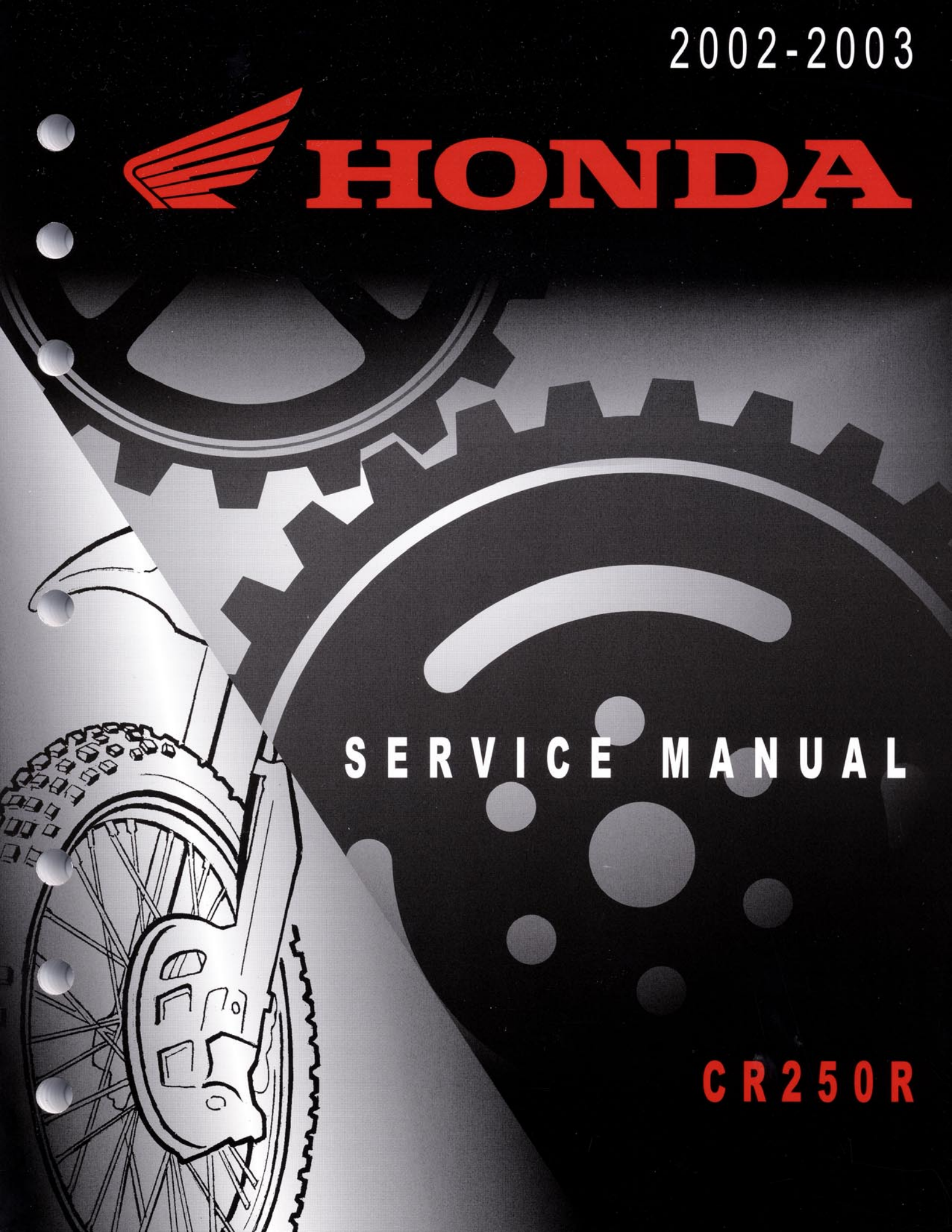

## **A Few Words About Safety Service Information**

The service and repair information contained in this manual is intended for use by qualified, professional technicians. Attempting service or repairs without the proper training, tools, and equipment could cause injury to you or others. It could also damage the vehicle or create an unsafe condition.

This manual describes the proper methods and procedures for performing service, maintenance, and repairs. Some procedures require the use of specially designed tools and dedicated equipment. Any person who intends to use a replacement part, service procedure or a tool that is not recommended by Honda, must determine the risks to their personal safety and the safe operation of the vehicle.

If you need to replace a part, use genuine Honda parts with the correct part number or an equivalent part. We strongly recommend that you do not use replacement parts of inferior quality.

### **For Your Customer's Safety**

Proper service and maintenance are essential to the customer's safety and the reliability of the vehicle. Any error or oversight while servicing a vehicle can result in faulty operation, damage to the vehicle, or injury to others.

### **For Your Safety**

Because this manual is intended for the professional service technician, we do not provide warnings about many basic shop safety practices (e.g., hot parts – wear gloves). If you have not received shop safety training or do not feel confident about your knowledge of safe servicing practices, we recommended that you do not attempt to perform the procedures described in this manual.

Some of the most important general service safety precautions are given below. However, we cannot warn you of every conceivable hazard that can arise in performing service and repair procedures. Only you can decide whether or not you should perform a given task.

### **Important Safety Precautions**

Make sure you have a clear understanding of all basic shop safety practices and that you are wearing appropriate clothing and using safety equipment. When performing any service task, be especially careful of the following:

- Read all of the instructions before you begin, and make sure you have the tools, the replacement or repair parts, and the skills required to perform the tasks safely and completely.
- Protect your eyes by using proper safety glasses, goggles or face shields any time you hammer, drill, grind, pry or work around pressurized air or liquids, and springs or other stored-energy components. If there is any doubt, put on eye protection.
- Use other protective wear when necessary, for example gloves or safety shoes. Handling hot or sharp parts can cause severe burns or cuts. Before you grab something that looks like it can hurt you, stop and put on gloves.
- Protect yourself and others whenever you have the vehicle up in the air. Any time you lift the vehicle, either with a hoist or a jack, make sure it is always securely supported. Use jack stands.

Make sure the engine is off before you begin any servicing procedures, unless the instruction tells you to do otherwise. This will help eliminate several potential hazards:

- Carbon monoxide poisoning from engine exhaust: Be sure there is adequate ventilation whenever you run the engine.
- Burns from hot parts or coolant: Let the engine and exhaust system cool before working in those areas.
- Injury from moving parts: If the instruction tells you to run the engine, be sure your hands, fingers and clothing are out of the way.

Gasoline vapors and hydrogen gases from batteries are explosive. To reduce the possibility of a fire or explosion, be careful when working around gasoline or batteries.

- Use only a nonflammable solvent, not gasoline, to clean parts.
- Never drain or store gasoline in an open container.
- Keep all cigarettes, sparks and flames away from the battery and all fuel-related parts.

### **⚠ WARNING**

Improper service or repairs can create an unsafe condition that can cause your customer or others to be seriously hurt or killed.

Follow the procedures and precautions in this manual and other service materials carefully.

### **⚠ WARNING**

Failure to properly follow instructions and precautions can cause you to be seriously hurt or killed.

Follow the procedures and precautions in this manual carefully.

# HOW TO USE THIS MANUAL

This service manual describes the service procedures for the CR250R.

Follow the Maintenance Schedule (Section 3) recommendations to ensure that the vehicle is in peak operating condition.

Performing the first scheduled maintenance is very important. It compensates for the initial wear that occurs during the break-in period.

Sections 1 and 3 apply to the whole motorcycle. Section 2 illustrates procedures for removal/installation of components that may be required to perform service described in the following sections.

Section 4 through 15 describe parts of the motorcycle, grouped according to location.

Find the section you want on this page, then turn to the table of contents on the first page of the section.

Most sections start with an assembly or system illustration, service information and troubleshooting for the section. The subsequent pages give detailed procedures.

If you don't know the source of the trouble, go to section 17 Troubleshooting.

Your safety, and the safety of others, is very important. To help you make informed decisions we have provided safety messages and other information throughout this manual. Of course, it is not practical or possible to warn you about all the hazards associated with servicing this vehicle. You must use your own good judgement.

You will find important safety information in a variety of forms including:

- Safety Labels – on the vehicle
- Safety Messages – preceded by a safety alert symbol  and one of three signal words, DANGER, WARNING, or CAUTION.

These signal words mean:

**▲ DANGER** You WILL be KILLED or SERIOUSLY HURT if you don't follow instructions.

**▲ WARNING** You CAN be KILLED or SERIOUSLY HURT if you don't follow instructions.

**▲ CAUTION** You CAN be HURT if you don't follow instructions.

- Instructions – how to service this vehicle correctly and safely.

As you read this manual, you will find information that is preceded by a  symbol. The purpose of this message is to help prevent damage to your vehicle, other property, or the environment.

**ALL INFORMATION, ILLUSTRATIONS, DIRECTIONS AND SPECIFICATIONS INCLUDED IN THIS PUBLICATION ARE BASED ON THE LATEST PRODUCT INFORMATION AVAILABLE AT THE TIME OF APPROVAL FOR PRINTING. HONDA MOTOR CO., LTD. RESERVES THE RIGHT TO MAKE CHANGES AT ANY TIME WITHOUT NOTICE AND WITHOUT INCURRING ANY OBLIGATION WHATSOEVER. NO PART OF THIS PUBLICATION MAY BE REPRODUCED WITHOUT WRITTEN PERMISSION. THIS MANUAL IS WRITTEN FOR PERSONS WHO HAVE ACQUIRED BASIC KNOWLEDGE OF MAINTENANCE ON HONDA MOTORCYCLES, MOTOR SCOOTERS OR ATVS.**











HONDA MOTOR CO., LTD.  
SERVICE PUBLICATION OFFICE

# CONTENTS

	<b>GENERAL INFORMATION</b>	<b>1</b>
	<b>FRAME/BODY PANELS/EXHAUST SYSTEM</b>	<b>2</b>
	<b>MAINTENANCE</b>	<b>3</b>
<b>ENGINE AND DRIVE TRAIN</b>	<b>FUEL SYSTEM</b>	<b>4</b>
	<b>COOLING SYSTEM</b>	<b>5</b>
	<b>ENGINE REMOVAL/INSTALLATION</b>	<b>6</b>
	<b>CYLINDER HEAD/CYLINDER/PISTON</b>	<b>7</b>
	<b>RC VALVE</b>	<b>8</b>
	<b>CLUTCH/KICKSTARTER/GEARSHIFT LINKAGE</b>	<b>9</b>
	<b>CRANKCASE/CRANKSHAFT/TRANSMISSION</b>	<b>10</b>
<b>CHASSIS</b>	<b>FRONT WHEEL/SUSPENSION/STEERING</b>	<b>11</b>
	<b>REAR WHEEL/SUSPENSION</b>	<b>12</b>
	<b>HYDRAULIC BRAKE</b>	<b>13</b>
<b>ELECTRICAL</b>	<b>IGNITION SYSTEM</b>	<b>14</b>
	<b>WIRING DIAGRAM</b>	<b>15</b>
	<b>TECHNICAL FEATURES</b>	<b>16</b>
	<b>TROUBLESHOOTING</b>	<b>17</b>
	<b>INDEX</b>	<b>18</b>

## SYMBOLS

The symbols used throughout this manual show specific service procedures. If supplementary information is required pertaining to these symbols, it would be explained specifically in the text without the use of the symbols.

	Replace the part(s) with new one(s) before assembly.
	Use the recommended engine oil, unless otherwise specified.
	Use molybdenum oil solution (mixture of the engine oil and molybdenum grease in a ratio of 1 : 1).
	Use multi-purpose grease (lithium based multi-purpose grease NLGI #2 or equivalent).
	Use molybdenum disulfide grease (containing more than 3% molybdenum disulfide, NLGI #2 or equivalent). Example: Molykote® BR-2 plus manufactured by Dow Corning U.S.A. Multi-purpose M-2 manufactured by Mitsubishi Oil, Japan
	Use molybdenum disulfide paste (containing more than 40% molybdenum disulfide, NLGI #2 or equivalent). Example: Molykote® G-n Paste manufactured by Dow Corning U.S.A. Honda Moly 60 (U.S.A. only) Rocol ASP manufactured by Rocol Limited, U.K. Rocol Paste manufactured by Sumico Lubricant, Japan
	Use silicone grease.
	Apply a locking agent. Use a medium strength locking agent unless otherwise specified.
	Apply sealant.
	Use DOT 4 brake fluid. Use the recommended brake fluid unless otherwise specified.
	Use fork or suspension fluid.

# 1. GENERAL INFORMATION

SERVICE RULES	1-1	TOOLS	1-13
MODEL IDENTIFICATION	1-1	LUBRICATION & SEAL POINTS	1-15
SPECIFICATIONS	1-3	CABLE & HARNESS ROUTING	1-17
TORQUE VALUES	1-10	OPTIONAL PARTS	1-21

## SERVICE RULES

1. Use genuine HONDA or HONDA-recommended parts and lubricants or their equivalents. Parts that do not meet HONDA's design specifications may cause damage to the motorcycle.
2. Use the special tools designed for this product to avoid damage and incorrect assembly.
3. Use only metric tools when servicing the motorcycle. Metric bolts, nuts and screws are not interchangeable with English fasteners.
4. Install new gaskets, O-rings, cotter pins, and lock plates when reassembling.
5. When tightening bolts or nuts, begin with the larger diameter or inner bolt first. Then tighten to the specified torque diagonally in incremental steps unless a particular sequence is specified.
6. Clean parts in cleaning solvent upon disassembly. Lubricate any sliding surfaces before reassembly.
7. After reassembly, check all parts for proper installation and operation.
8. Route all electrical wires as shown on pages 1-17 through 1-20, Cable and Harness Routing.

## MODEL IDENTIFICATION



## GENERAL INFORMATION

---

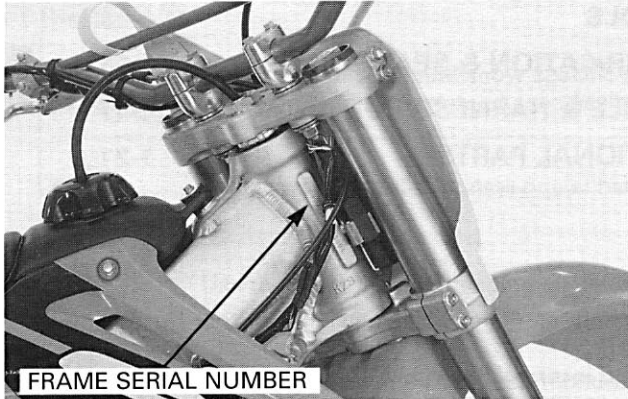

- (1) The frame serial number is stamped on the right side of the steering head.

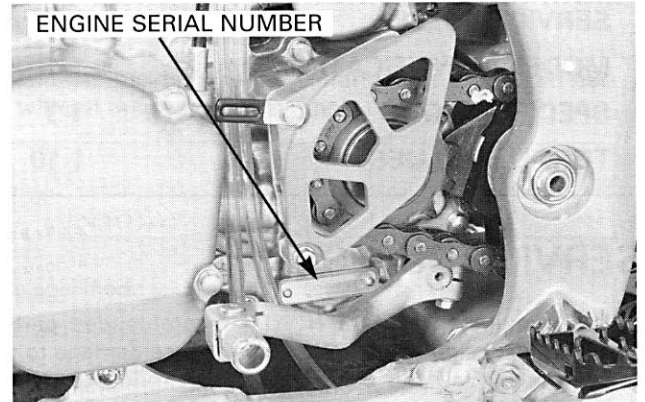

- (2) The engine serial number is stamped on the lower left side of the crankcase.

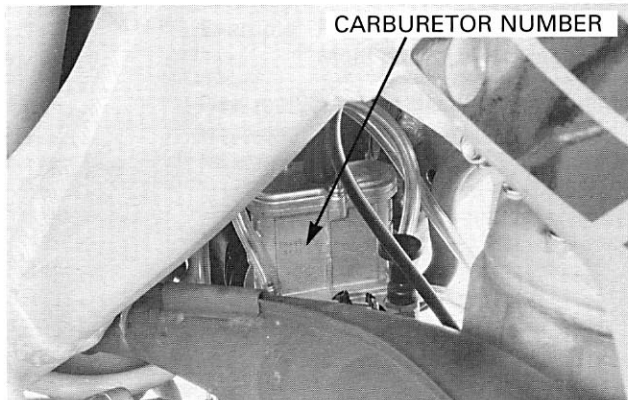

- (3) The carburetor identification number is stamped on the front side of the carburetor body as shown.

**SPECIFICATIONS**

GENERAL	ITEM	SPECIFICATIONS
DIMENSIONS	Overall length Overall width Overall height Wheelbase Seat height Footpeg height Ground clearance Dry weight	2,190 mm (86.2 in) 823 mm (32.4 in) 1,269 mm (50.0 in) 1,491 mm (58.7 in) 950 mm (37.4 in) 436 mm (17.2 in) 346 mm (13.6 in) 96.5 kg (213 lbs)
FRAME	Frame type Front suspension Front suspension axle travel Front suspension cushion stroke Rear suspension Rear wheel travel Rear damper Front tire size Rear tire size Front tire brand Rear tire brand Front brake Front brake swept area Rear brake Rear brake swept area Caster angle Trail length Fuel tank capacity	Twin tube Telescopic fork 281 mm (11.1 in) 315 mm (12.4 in) Swingarm/Pro-link 319 mm (12.6 in) Decarbon type with nitrogen gas filled damper 80/100-21 51M 110/90-19 62M (Dunlop) K490G (Dunlop) K695 Hydraulic single disc 334.5 cm <sup>2</sup> (51.8 in <sup>2</sup> ) Hydraulic single disc 391.1 cm <sup>2</sup> (60.6 in <sup>2</sup> ) 26° 44' 106.7 mm (4.2 in) 7.7 liter (2.0 US gal, 1.7 Imp gal)
ENGINE	Bore and stroke Displacement Compression ratio Lubrication system Cooling system Air filtration Crankshaft type Engine dry weight Cylinder arrangement	66.4 x 72.0 mm (2.61 x 2.83 in) 249.3 cm <sup>3</sup> (15.2 cu-in) 8.5 : 1 Fuel/oil mix Liquid cooled Oiled polyurethane foam Assembly-type 23.0 kg (50.7 lbs) Single cylinder, inlined 9° from vertical
CARBURETOR	Carburetor type Displacement	Piston valve type 38.3 mm (1.50 in)

## GENERAL INFORMATION

---

GENERAL (Cont'd)		
	ITEM	SPECIFICATIONS
DRIVE TRAIN	Clutch system Clutch operation system Transmission Primary reduction Final reduction Gear ratio           1st 2nd 3rd 4th 5th  Gearshift pattern	Multi-plate, wet Cable operated Constant mesh, 5-speeds 3.000 (63/21) 3.692 (48/13) 1.800 (27/15) 1.470 (25/17) 1.210 (23/19) 1.000 (21/21) 0.869 (20/23)  Left foot operated return system, 1 - N - 2 - 3 - 4 - 5
ELECTRICAL	Ignition system	CDI



## GENERAL INFORMATION

<b>LUBRICATION SYSTEM</b>		
ITEM		STANDARD
Recommended engine oil		PRO HONDA HP2 2-stroke oil or equivalent
Fuel/oil mixing ratio		32:1
Transmission oil capacity	After draining	0.65 liter (0.69 US qt, 0.57 Imp qt)
	After disassembly	0.70 liter (0.74 US qt, 0.62 Imp qt)
Recommended transmission oil		Pro Honda HP Trans oil, Pro Honda GN4, HP4 (without molybdenum additives) 4-stroke oil or equivalent motor oil API service classification: SG or higher except oils labeled as energy conserving on the circular API service label  Viscosity: SAE 10W-40 JASO T903: MA

<b>FUEL SYSTEM</b>		
ITEM		SPECIFICATIONS
Carburetor identification number	'02	TMX 11B
	After '02	TMX 11C
Main jet	'02	#380
	After '02	#420
Slow jet	'02	#32.5
	After '02	#30
Jet needle	'02	6BEY30-74
	After '02	6BHY38-73
Jet needle clip position (Standard)		2nd
Pilot screw initial opening		1-1/2 turns out
Float level		15.0 mm (0.59 in)
Throttle grip free play		3 - 5 mm (1/8 - 1/4 in)

<b>COOLING SYSTEM</b>		
ITEM		SPECIFICATIONS
Coolant capacity	At change	1.08 liter (1.14 US qt, 0.95 Imp qt)
	At disassembly	1.15 liter (1.22 US qt, 1.01 Imp qt)
Radiator cap relief pressure		108 - 137 kPa (1.1 - 1.4 kgf/cm <sup>2</sup> , 16 - 20 psi)
Recommended antifreeze		Pro Honda HP coolant or equivalent high quality ethylene glycol antifreeze containing silicate-free corrosion inhibitors
Standard coolant concentration		1:1 mixture with soft water

## GENERAL INFORMATION

Unit: mm (in)

CYLINDER HEAD/CYLINDER/PISTON			STANDARD	SERVICE LIMIT
ITEM				
Cylinder head warpage			—	0.05 (0.002)
Cylinder	I.D.	A	66.398 – 66.405 (2.6141 – 2.6244)	66.460 (2.615)
		B	66.390 – 66.398 (2.6138 – 2.6141)	66.428 (2.615)
	Out-of-round		—	0.05 (0.002)
	Taper		—	0.05 (0.002)
	Warpage		—	0.05 (0.002)
Piston, piston rings	Piston mark direction		“IN” mark facing toward the intake side	—
	Piston O.D.	A	66.330 – 66.338 (2.6114 – 2.6117)	66.28 (2.609)
		B	66.323 – 66.330 (2.6111 – 2.6114)	66.273 (2.609)
	Piston O.D. measurement point		15 – 25 mm (0.59 – 0.98 in) from bottom of skirt	—
	Piston pin bore I.D.		18.007 – 18.013 (0.7089 – 0.7092)	18.02 (0.709)
	Piston pin O.D.		17.994 – 18.000 (0.7084 – 0.7087)	17.98 (0.707)
	Piston-to-piston pin clearance		0.007 – 0.019 (0.0003 – 0.0007)	0.04 (0.0016)
	Piston ring-to-ring groove clearance	Top	0.045 – 0.075 (0.002 – 0.003)	0.095 (0.0037)
Second		0.025 – 0.055 (0.001 – 0.002)	0.075 (0.0029)	
Piston ring end gap		0.40 – 0.55 (0.016 – 0.022)	0.65 (0.026)	
Cylinder-to-piston clearance			0.060 – 0.075 (0.0024 – 0.0029)	0.09 (0.004)
Connecting rod small end I.D.			21.997 – 22.009 (0.8660 – 0.8665)	22.02 (0.867)

Unit: mm (in)

CLUTCH/GEARSHIFT LINKAGE			STANDARD	SERVICE LIMIT
ITEM				
Clutch lever free play			10 – 20 (3/8 – 3/4)	—
Clutch spring free length			45.7 (1.83)	44.7 (1.76)
Clutch outer guide O.D.			27.987 – 28.000 (1.1018 – 1.1024)	27.97 (1.101)
Clutch disc thickness			2.92 – 3.08 (0.114 – 0.121)	2.85 (0.112)
Clutch plate warpage			—	0.20 (0.008)
Kickstarter pinion gear I.D.			22.007 – 22.028 (0.8664 – 0.8672)	22.05 (0.868)
Kickstarter spindle O.D.			21.959 – 21.980 (0.8645 – 0.8654)	21.95 (0.864)
Kickstarter idle gear I.D.			20.020 – 20.041 (0.7882 – 0.7890)	20.07 (0.790)
Kickstarter idle gear bushing	I.D.		17.000 – 17.018 (0.6693 – 0.6700)	17.04 (0.671)
	O.D.		19.979 – 20.000 (0.7866 – 0.7874)	19.96 (0.786)
Countershaft I.D. at kickstarter idle gear			16.966 – 16.984 (0.6680 – 0.6687)	16.95 (0.667)

## GENERAL INFORMATION

Unit: mm (in)

CRANKSHAFT/TRANSMISSION				
ITEM			STANDARD	SERVICE LIMIT
Crankshaft	Side clearance		0.4 – 0.8 (0.02 – 0.03)	0.9 (0.04)
	Radial clearance		0.010 – 0.022 (0.0004 – 0.0009)	0.03 (0.001)
	Runout		—	0.05 (0.002)
Transmission	Gear I.D.	M4	28.007 – 28.028 (1.1026 – 1.1035)	28.05 (1.104)
		M5	25.020 – 25.041 (0.9850 – 0.9859)	25.07 (0.987)
		C1	22.020 – 22.041 (0.8669 – 0.8678)	22.07 (0.869)
		C2	30.020 – 30.041 (1.1819 – 1.1827)	30.07 (1.184)
		C3	25.020 – 25.041 (0.9850 – 0.9859)	25.07 (0.987)
	Gear bushing O.D.	M4	27.959 – 27.980 (1.1007 – 1.1015)	27.94 (1.100)
		C1	21.979 – 22.000 (0.8653 – 0.8661)	21.95 (0.864)
		C2	29.979 – 30.000 (1.1802 – 1.1811)	29.95 (1.179)
	Gear bushing I.D.	C1	19.000 – 19.021 (0.7480 – 0.7489)	19.04 (0.750)
		C2	27.000 – 27.021 (1.0630 – 1.0638)	27.04 (1.064)
	Gear-to-bushing clearance	M4	0.027 – 0.069 (0.0011 – 0.0027)	0.11 (0.004)
		C1	0.020 – 0.062 (0.0008 – 0.0024)	0.12 (0.005)
		C2	0.020 – 0.062 (0.0008 – 0.0024)	0.12 (0.005)
	Mainshaft O.D.	at M5	24.959 – 24.980 (0.9826 – 0.9835)	24.94 (0.982)
	Countershaft O.D.	at C1 bushing	18.959 – 18.980 (0.7464 – 0.7472)	18.94 (0.746)
		at C2 bushing	26.959 – 26.980 (1.0614 – 1.0622)	26.94 (1.061)
		at C3	24.959 – 24.979 (0.9826 – 0.9834)	24.96 (0.983)
	Gear-to-shaft clearance	M5	0.040 – 0.082 (0.0016 – 0.0032)	0.13 (0.005)
		C3	0.041 – 0.082 (0.0016 – 0.0032)	0.11 (0.004)
	Bushing-to-shaft clearance	C1	0.020 – 0.062 (0.0008 – 0.0024)	0.12 (0.005)
		C3	0.020 – 0.062 (0.0008 – 0.0024)	0.12 (0.005)
Shift fork, fork shaft	Fork claw thickness		4.93 – 5.00 (0.194 – 0.197)	4.8 (0.19)
	Shift fork I.D.	C	11.003 – 11.024 (0.4332 – 0.4340)	11.04 (0.435)
		R/L	12.035 – 12.056 (0.4738 – 0.4746)	12.07 (0.475)
	Fork shaft O.D.	C	10.983 – 10.994 (0.4324 – 0.4328)	10.97 (0.432)
		R/L	11.966 – 11.984 (0.4711 – 0.4718)	11.95 (0.470)

## GENERAL INFORMATION

Unit: mm (in)

FRONT WHEEL/SUSPENSION/STEERING			STANDARD	SERVICE LIMIT
ITEM				
Cold tire pressure			100 kPa (1.0 kgf/cm <sup>2</sup> , 15 psi)	—
Axle runout			—	0.20 (0.008)
Wheel rim runout	Radial		—	2.0 (0.08)
	Axial		—	2.0 (0.08)
Wheel hub-to-rim distance			27.25 (1.073)	—
Fork	Spring free length		494 (19.45)	487 (19.17)
	Slider runout		—	0.20 (0.008)
	Recommended fork fluid		Pro Honda HP Fork Oil 5W or equivalent	
	Fluid capacity	'02	409 cm <sup>3</sup> (13.8 US oz, 14.4 Imp oz)	—
After '02		405 cm <sup>3</sup> (13.7 US oz, 14.3 Imp oz)	—	
Compression damping adjuster standard position	'02	13 clicks out from full in	—	
	After '02	14 clicks out from full in	—	
Rebound damping adjuster standard position			15 clicks out from full in	—

Unit: mm (in)

REAR WHEEL/SUSPENSION			STANDARD	SERVICE LIMIT
ITEM				
Cold tire pressure			100 kPa (1.0 kgf/cm <sup>2</sup> , 15 psi)	—
Axle runout			—	0.20 (0.008)
Wheel rim runout	Radial		—	2.0 (0.08)
	Axial		—	2.0 (0.08)
Wheel hub-to-rim distance			47.00(1.850)	—
Drive chain slack			25 – 35 (1.0 – 1.4)	—
Drive chain size/link	DID		520DMA2-114	—
Drive chain slider thickness			—	5 (0.2)
Drive chain tensioner roller O.D.	Upper		—	25 (0.98)
	Lower		—	39 (1.54)
Shock absorber	Damper gas pressure		981 kPa (10.0 kgf/cm <sup>2</sup> , 142 psi)	—
	Damper compressed gas		Nitrogen gas	—
	Damper rod compressed force at 13 mm compressed		20.0 – 24.0 kgf (44.1 – 52.9 lbf)	—
	Spring installed length (standard)		265 (10.43)	—
High speed compression damping adjuster standard position	'02	1•3/4 – 2•1/4 turns out form full in	—	
	After '02	1•11/12 – 2•5/12 turns out form full in	—	
Low speed compression damping adjuster standard position	'02	7 clicks out from full in	—	
	After '02	8 clicks out from full in	—	
Rebound damping adjuster standard position	'02	8 – 11 clicks out from full in	—	
	After '02	4 – 7 clicks out from full in	—	

## GENERAL INFORMATION

Unit: mm (in)

HYDRAULIC BRAKE		STANDARD	SERVICE LIMIT
	ITEM		
Front	Specified brake fluid	DOT 4	—
	Brake pad wear indicator	—	1.0 (0.04)
	Brake disc thickness	3.0 (0.12)	2.5 (0.10)
	Brake disc runout	—	0.15 (0.006)
	Master cylinder I.D.	11.00 (0.433)	—
	Caliper cylinder I.D.	27.00 (1.063)	—
Rear	Specified brake fluid	DOT 4	—
	Brake pad wear indicator	—	1.0 (0.04)
	Brake disc thickness	4.0 (0.16)	3.5 (0.14)
	Brake disc runout	—	0.15 (0.006)
	Master cylinder I.D.	9.52 (0.375)	—
	Master piston O.D.	9.49 (0.373)	—
	Caliper cylinder I.D.	22.65 (0.892)	—
	Caliper piston O.D.	22.60 (0.889)	—

IGNITION SYSTEM		SPECIFICATIONS
	ITEM	
Spark plug	Standard (NGK)	BR8EG
	Standard (DENSO)	W24ESR-V
	Optional (NGK)	BR8EV
	Optional (DENSO)	W24ESR-G
Spark plug gap		0.5 – 0.6 mm (0.020 – 0.024 in)
Ignition coil resistance (at 20°C/68°F)	Primary	0.1 – 0.3 Ω
	Secondary with plug cap	9 – 16 Ω
	Secondary without plug cap	4 – 8 Ω
Ignition coil peak voltage		100 V minimum
Ignition pulse generator resistance (at 20°C/68°F)		180 – 280 Ω
Ignition pulse generator peak voltage		0.7 V minimum
Alternator coil resistance (at 20°C/68°F)		0.5 – 4 Ω
Ignition timing ("F" mark)	'02	18 ± 2° BTDC at 2,000 rpm
	After '02	20 ± 1° BTDC at 4,000 rpm

## GENERAL INFORMATION

### TORQUE VALUES

FASTENER TYPE	TORQUE N·m (kgf·m, lbf·ft)	FASTENER TYPE	TORQUE N·m (kgf·m, lbf·ft)
5 mm hex bolt and nut	5 (0.5, 3.6)	5 mm screw	4 (0.4, 2.9)
6 mm hex bolt and nut	10 (1.0, 7)	6 mm screw	9 (0.9, 6.5)
8 mm hex bolt and nut	22 (2.2, 16)	6 mm flange bolt (8 mm head, small flange)	10 (1.0, 7)
10 mm hex bolt and nut	34 (3.5, 25)	6 mm flange bolt (8 mm head, large flange)	12 (1.2, 9)
12 mm hex bolt and nut	54 (5.5, 40)	6 mm flange bolt (10 mm head) and nut	12 (1.2, 9)
		8 mm flange bolt and nut	26 (2.7, 20)
		10 mm flange bolt and nut	39 (4.0, 29)

- Torque specifications listed below are for important fasteners.
- Others should be tightened to standard torque values listed above.

NOTES: 1. Apply a locking agent to the threads.  
 2. Apply oil to the threads and flange surface.  
 3. Stake.  
 4. U-nut.  
 5. UBS nut.

ENGINE				
ITEM	Q'TY	THREAD DIA. (mm)	TORQUE N·m (kgf·m, lbf·ft)	REMARKS
<b>MAINTENANCE:</b>				
Oil drain bolt	1	12	29 (3.0, 22)	
Spark plug	1	14	18 (1.8, 13)	
Oil check bolt	1	6	10 (1.0, 7)	
<b>FUEL SYSTEM:</b>				
Throttle cable holder	1	10	3 (0.3, 2.2)	
Float pin set screw	1	4	2 (0.2, 1.4)	
Needle jet holder	1	8	3 (0.3, 2.2)	
Main jet	1	5.3	2 (0.2, 1.4)	
Slow jet	1	4	1 (0.1, 0.7)	
Carburetor top screw	1	5	2 (0.2, 1.4)	
Throttle stop screw lock nut	1	5	2 (0.2, 1.4)	
Float chamber screw	1	4	2 (0.2, 1.4)	
Carburetor drain plug	1	12	7 (0.7, 5.1)	
Choke valve	1	—	4 (0.4, 2.9)	
Float valve seat set screw	1	3	1 (0.1, 0.7)	
Insulator bolt	6	6	12 (1.2, 9)	
Reed valve stopper screw	6	5	1 (0.1, 0.7)	
<b>COOLING SYSTEM:</b>				
Water pump impeller	1	7	12 (1.2, 9)	
Water pump cover bolt	2	6	12 (1.2, 9)	
Coolant drain bolt	1	6	10 (1.0, 7)	
<b>CYLINDER HEAD/CYLINDER/PISTON:</b>				
Cylinder stud bolt	6	8	12 (1.2, 9)	
Cylinder head nut	6	8	27 (2.8, 20)	
Cylinder mounting nut	4	10	39 (4.0, 29)	
Exhaust pipe joint nut	3	6	12 (1.2, 9)	
<b>RC VALVE:</b>				
Flap valve shaft nut	1	6	10 (1.0, 7)	
RC valve cover bolt	4	5	10 (1.0, 7)	
RC valve stopper plate socket bolt	1	6	10 (1.0, 7)	

## GENERAL INFORMATION

<b>ENGINE (Cont'd)</b>				
ITEM	Q'TY	THREAD DIA. (mm)	TORQUE N•m (kgf•m, lbf•ft)	REMARKS
<b>CLUTCH/KICKSTARTER/GEARSHIFT LINKAGE:</b>				
Gearshift drum center pin	1	8	22 (2.2, 16)	NOTE 1
Gearshift drum stopper arm bolt	1	6	12 (1.2, 9)	
Clutch center lock nut	1	18	80 (8.2, 59)	
Clutch spring bolt	6	6	10 (1.0, 7)	
Gearshift pedal bolt	1	6	12 (1.2, 9)	
Kickstarter pedal bolt	1	8	38 (3.9, 28)	
<b>CRANKCASE/CRANKSHAFT/TRANSMISSION:</b>				
Countershaft bearing set plate screw	2	6	10 (1.0, 7)	NOTE 1
Gearshift drum bearing set plate bolt	2	6	10 (1.0, 7)	NOTE 1
Drive sprocket bolt	1	8	26 (2.7, 20)	NOTE 5
Primary drive gear bolt	1	10	64 (6.5, 47)	
<b>ALTERNATOR/STARTER CLUTCH:</b>				
Flywheel nut	1	12	54 (5.5, 40)	
Alternator cover bolt	4	6	10 (1.0, 7)	

<b>FRAME</b>				
ITEM	Q'TY	THREAD DIA. (mm)	TORQUE N•m (kgf•m, lbf•ft)	REMARKS
<b>FRAME BODY PANELS/EXHAUST SYSTEM:</b>				
Seat mounting bolt	2	8	27 (2.8, 20)	
Sub-frame mounting bolt (upper)	1	8	30 (3.1, 22)	
(lower)	2	8	30 (3.1, 22)	
Radiator shroud mounting bolt	2	5	6 (0.6, 4.3)	
Seat bracket screw	1	5	4 (0.4, 2.9)	
Shroud mounting bolt	8	6	6 (0.6, 4.3)	
<b>ENGINE MOUNTING:</b>				
Engine hanger plate nut	2	8	26 (2.7, 20)	
Engine upper mounting nut	1	10	54 (5.5, 40)	
Engine lower mounting nut (front)	1	10	54 (5.5, 40)	
(lower)	1	10	54 (5.5, 40)	
<b>FRONT WHEEL/SUSPENSION/STEERING:</b>				
Front axle nut	1	16	88 (9.0, 65)	
Front axle holder bolt	4	8	20 (2.0, 14)	
Front spoke nipple	36	BC 3.5	3.7 (0.38, 2.7)	
Front rim lock	1	8	12 (1.2, 9)	
Front brake disc nut	6	6	16 (1.6, 12)	
Steering stem nut	1	26	108 (11.0, 80)	
Steering stem adjusting nut	1	30	7 (0.7, 5.1)	
Fork pinch bolt (top)	4	8	22 (2.2, 16)	
(bottom)	4	8	20 (2.0, 14)	
Fork cap	2	39	29 (3.0, 22)	
Fork center bolt	2	22	69 (7.0, 51)	
Fork center lock nut	2	12	22 (2.2, 16)	
Plug bolt	2	5	1.2 (0.12, 0.9)	
Fork damper	2	50	34 (3.5, 25)	
Fork protector mounting bolt	6	6	7 (0.7, 5.1)	NOTE 1
Front brake disc cover bolt	2	6	13 (1.3, 9)	NOTE 1
Brake lever pivot bolt/nut	1/1	6/6	5.9 (0.6, 4.3)	
Handlebar upper holder bolt	4	8	22 (2.2, 16)	
Handlebar lower holder nut	2	10	44 (4.5, 33)	NOTE 4
Clutch lever pivot bolt	1	6	2 (0.2, 1.4)	
Clutch lever pivot nut	1	6	10 (1.0, 7)	
Clutch lever holder bolt	2	6	9 (0.9, 6.5)	
Throttle housing bolt	2	6	9 (0.9, 6.5)	
Throttle housing cover screw	1	4	1.5 (0.15, 1.1)	
Engine stop switch button screw	1	4	1.5 (0.15, 1.1)	

## GENERAL INFORMATION

FRAME (Cont'd)				
ITEM	Q'TY	THREAD DIA. (mm)	TORQUE N·m (kgf·m, lbf·ft)	REMARKS
<b>REAR WHEEL SUSPENSION:</b>				
Rear axle nut	1	22	127 (13.0, 93)	
Rear spoke nipple	32	4.5	3.7 (0.38, 2.7)	
Rear rim lock	1	8	12 (1.2, 9)	
Rear brake disc nut	4	6	16 (1.6, 12)	
Final driven sprocket nut	6	8	32 (3.3, 24)	NOTE 4
Rear wheel bearing retainer	1	50	44 (4.5, 33)	
Swingarm pivot nut	1	16	88 (9.0, 65)	
Shock arm (swingarm side)	1	12	79 (8.1, 59)	NOTE 2, 4
(shock link side)	1	12	79 (8.1, 59)	NOTE 4
Shock link (frame side)	1	12	79 (8.1, 59)	NOTE 4
Shock absorber mounting nut (upper)	1	10	44 (4.5, 33)	NOTE 4
(lower)	1	10	44 (4.5, 33)	NOTE 4
Shock absorber spring lock nut	1	60	44 (4.5, 33)	
Drive chain roller bolt/nut	1	8	12 (1.2, 9)	
Drive chain guide mounting nut	2	6	12 (1.2, 9)	NOTE 4
Drive chain adjusting nut	2	8	27 (2.8, 20)	
Drive chain slider screw	3	5	4 (0.4, 2.9)	
Shock absorber damper rod end nut	1	12	37 (3.8, 27)	NOTE 3
Shock absorber damping adjuster	1	27	29 (3.0, 22)	
Right and left step bolt (upper)	2	12	55 (5.6, 41)	
(lower)	2	10	30 (3.0, 23)	
<b>HYDRAULIC BRAKE:</b>				
Brake hose oil bolt	4	10	34 (3.5, 25)	
Brake lever adjuster lock nut	1	5	5.9 (0.6, 4.3)	
Front brake hose guide bolt	1	6	5.2 (0.53, 3.8)	
Rear brake hose guide screw	2	5	1.2 (0.12, 0.9)	
Front master cylinder reservoir cover screw	2	4	1.0 (0.1, 0.7)	
Front master cylinder holder bolt	2	6	9.9 (1.0, 7)	
Front caliper mounting bolt	2	8	30 (3.1, 22)	NOTE 1
Brake caliper bleed valve	2	8	5.4 (0.55, 4.0)	
Rear brake disc guard mounting bolt	2	6	6.8 (0.7, 5.1)	
Rear master cylinder reservoir cover bolt	2	4	1.0 (0.1, 0.7)	
Rear master cylinder mounting bolt	2	6	13 (1.3, 9)	
Front brake caliper pin bolt	2	8	22 (2.2, 16)	NOTE 1
Brake caliper pad pin	2	10	18 (1.8, 13)	
Brake caliper pad pin plug	1	10	2 (0.2, 1.4)	
Rear caliper pin bolt	1	12	27 (2.8, 20)	
Rear caliper bracket pin bolt	1	8	12 (1.2, 9)	NOTE 1
Brake pedal pivot bolt	1	8	26 (2.7, 20)	
Rear master cylinder joint nut	1	6	6 (0.6, 4.3)	



**TOOLS**

- NOTES: 1. Equivalent commercially available in U.S.A.  
 2. Not available in U.S.A.  
 3. Alternative tool.  
 4. Newly provided tool.  
 5. Newly designed tool.

DESCRIPTION	TOOL NUMBER	REMARKS	REF. SEC.
Spoke nipple wrench, 6.6	070MA-KZ30100	NOTE 4	3, 12
Slider guide attachment	070MO-KZ30100	NOTE 2	12
Analogue tester	07308-0020001 (SANWA)	NOTE 1	14
Carburetor float level gauge	07401-0010000		4
Universal bearing puller	07631-0010000	NOTE 1	10
Pin spanner	07702-0020001	2 required	12
Bearing retainer wrench B	07710-0010200		12
Extension bar	07716-0020500	NOTE 1	11
Gear holder, 2.5	07724-0010100	or 07724-001A100 (U.S.A. only)	10
Clutch center holder	07724-0050002	or 07724-0050001 or equivalent commercially available in U.S.A.	9
Universal holder	07725-0030000		10, 14
Flywheel puller	07733-0010000	or 07933-0010000	14
Attachment, 37 x 40 mm	07746-0010200		10, 11
Attachment, 42 x 47 mm	07746-0010300		10
Attachment, 62 x 68 mm	07746-0010500		10
Attachment, 24 x 26 mm	07746-0010700		12
Attachment, 30 mm I.D.	07746-0030300		11
Pilot, 12 mm	07746-0040200		5
Pilot, 17 mm	07746-0040400		5, 10
Pilot, 20 mm	07746-0040500		11, 12
Pilot, 25 mm	07746-0040600		10, 12
Pilot, 28 mm	07746-0041100		10
Pilot, 19 mm	07746-0041400		12
Bearing remover shaft	07746-0050100		11, 12
Bearing remover head, 20 mm	07746-0050600		11
Bearing remover head, 25 mm	07746-0050800		12
Driver	07749-0010000		5, 10, 11, 12
Snap ring pliers	07914-SA50001		13
Steering stem socket	07916-3710100	or 07702-0020001 or 07916-3710101	11
Bearing remover set, 12 mm	07936-1660001	NOTE 2	5
- remover weight	07741-0010201	or 07936-371020A or 07936-3710200	
- remover, 12 mm	07936-1660101	or 07936-166010A (U.S.A. only)	
- remover head, 12 mm	07936-1660110	NOTE 2	
- remover shaft	07936-1660120	NOTE 2	
Remover handle	07936-3710100		10
Bearing remover, 17 mm	07936-3710300	or 07936-3710200	10
- remover weight	07741-0010201	or 07936-371020A or 07936-3710200	
Crankcase puller	07937-4300001	or 07937-4300000	10
- bolt, 6 mm	07PMC-KZ40100		
Water seal driver	07945-KA30000	07965-415000A (U.S.A. only) or GN-AH-65-415	5
Attachment, 28 x 30 mm	07946-1870100		5, 12
Ball race remover	07946-3710500		11
Driver	07949-3710001		12
Piston base	07958-2500001		11
Crankcase assembly tool set	07965-1660100	or 07965-1660101 or 07965-1660102 (Not available in U.S.A.)	10
- assembly tool shaft	07965-1660200		
- assembly collar	07965-1660300	or 07965-1660301 or 07965-1660302 or 07965-166030A	

## GENERAL INFORMATION

DESCRIPTION	TOOL NUMBER	REMARKS	REF. SEC.
Threaded adapter	07965-KA30000		10
Assembly collar	07946-VM00100		10
Threaded shaft	07965-VM00200	or 07931-ME4010B and 07931-HB3020A (U.S.A. only)	10
Spoke nipple wrench	07JMA-MR60100	NOTE 1	3, 11
Slider guide, 16 mm	07PMG-KZ40100	NOTE 2	12
Bearing race installer	07VMF-KZ30100		11
Installer shaft	07VMF-KZ30200		11
Fork seal driver, 47 mm	07VMD-KZ30100	or 07VMD-KZ3010A	11
Lock nut wrench, 50 mm	07WMA-KZ30100		11
Retainer wrench, 48 x 15 mm	07YMA-KZ40100		12
Pin spanner A	89201-KS6-810	2 required	12
Analogue tester	TH-5H (KOWA)	NOTE 1	14
Peak voltage adapter	07HGJ-0020100	NOTE 2	14

## LUBRICATION & SEAL POINTS

ENGINE		
LOCATION	MATERIAL	REMARKS
Connecting rod big end Connecting rod small end and needle bearing Both crankshaft journal Piston outer surface Piston pin outer surface Piston ring and ring groove Cylinder: Flap valve shaft rotating area Flap valve shaft outer surface Flap valve 6 mm hole inner surface	PRO Honda HP 2-stroke oil or equivalent	
Mainshaft spline and gear spinning area Kickstarter spindle serration Kickstarter spindle pinion gear spinning area Mainshaft and countershaft: Spline areas and gear rolling areas Water pump shaft bearing area Right crankcase outside bearing area (water pump, kickstarter) Gearshift spindle serration Gearshift drum groove Shift fork pawl Shift fork shaft surface	Molybdenum solution (mixture of engine oil and molybdenum grease with the ratio 100 g:70 cc)	
Bearing teeth, rolling and contact area Clutch lifter piece needle bearing area Crankshaft bearings Transmission bearings Transmission gears: Tooth surface, rolling areas and contact areas Clutch lifter	Pro Honda HP Trans oil, Pro Honda GN4, HP4 (without molybdenum additives) 4-stroke oil or equivalent motor oil API service classification: SG or higher except oils labeled as energy conserving on the circular API service label Viscosity: SAE 10W-40 JASO T903: MA	
Oil seal lips Water seal lips	Multi-purpose grease	
Countershaft bearing set plate bolt threads Gearshift drum bearing set plate bolt threads	Honda Anaerobic Thread Lock or equivalent	

## GENERAL INFORMATION

FRAME	LOCATION	MATERIAL	REMARKS
	Throttle cable end Throttle grip sliding surface	Pro Honda HP Trans oil, Pro Honda GN4, HP4 (without molybdenum additives) 4-stroke oil or equivalent motor oil API service classification: SG or higher except oils labeled as energy con- serving on the circular API service label Viscosity: SAE 10W-40 JASO T903: MA	
	Steering stem bearing Wheel bearing dust seal lips Wheel axle and swingarm pivot outer surface Throttle cable roller and collar Rear shock absorber spherical bearing Suspension linkage bearing Swingarm bearing Brake pedal pivot sliding surface Dust seal lips Exhaust chamber mouth piece O-ring	Multi-purpose grease	Apply a thin coat of grease.
	Brake lever pivot bolt sliding surface Brake lever adjusting bolt	Silicone grease	
	Fork protector mounting bolt Front brake caliper mounting bolt Fork center bolt thread Brake disc mounting bolt Rear brake disc guard mounting screw thread Brake caliper pin bolt Brake caliper pin bolt A thread Rear brake master cylinder mounting bolt thread	Honda Anaerobic Thread Lock or equivalent	
	Fork cap O-ring Fork oil seal lips	Pro Honda HP Fork Oil 5W or equivalent	
	Handlebar grip	Honda Bond A or Honda hand Grip Cement (U.S.A. only)	

# CABLE & HARNESS ROUTING

THROTTLE CABLE      ENGINE STOP SWITCH WIRE

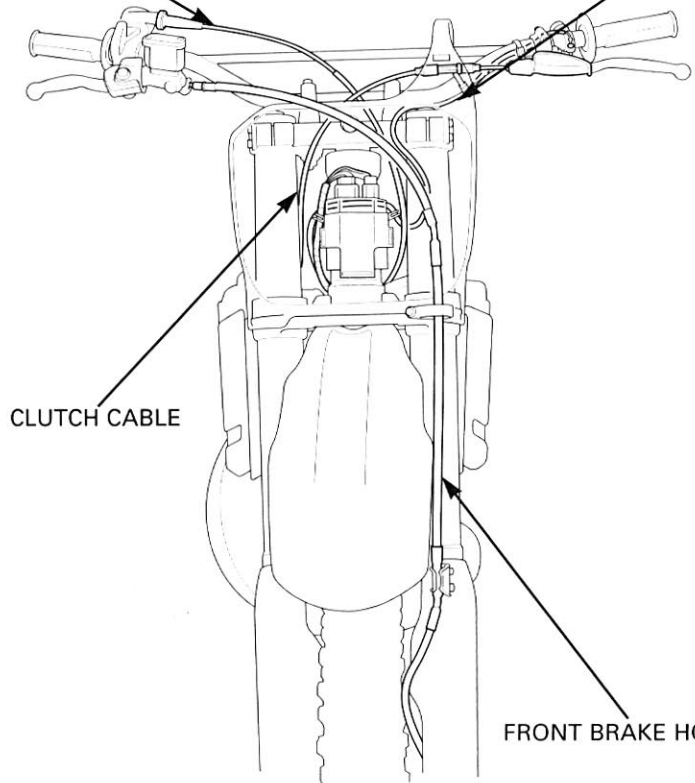

CLUTCH CABLE      ENGINE STOP SWITCH WIRE

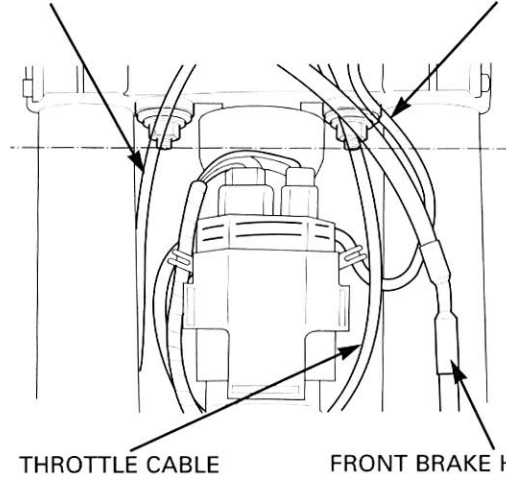

REGULATOR/RECTIFIER      CLUTCH CABLE

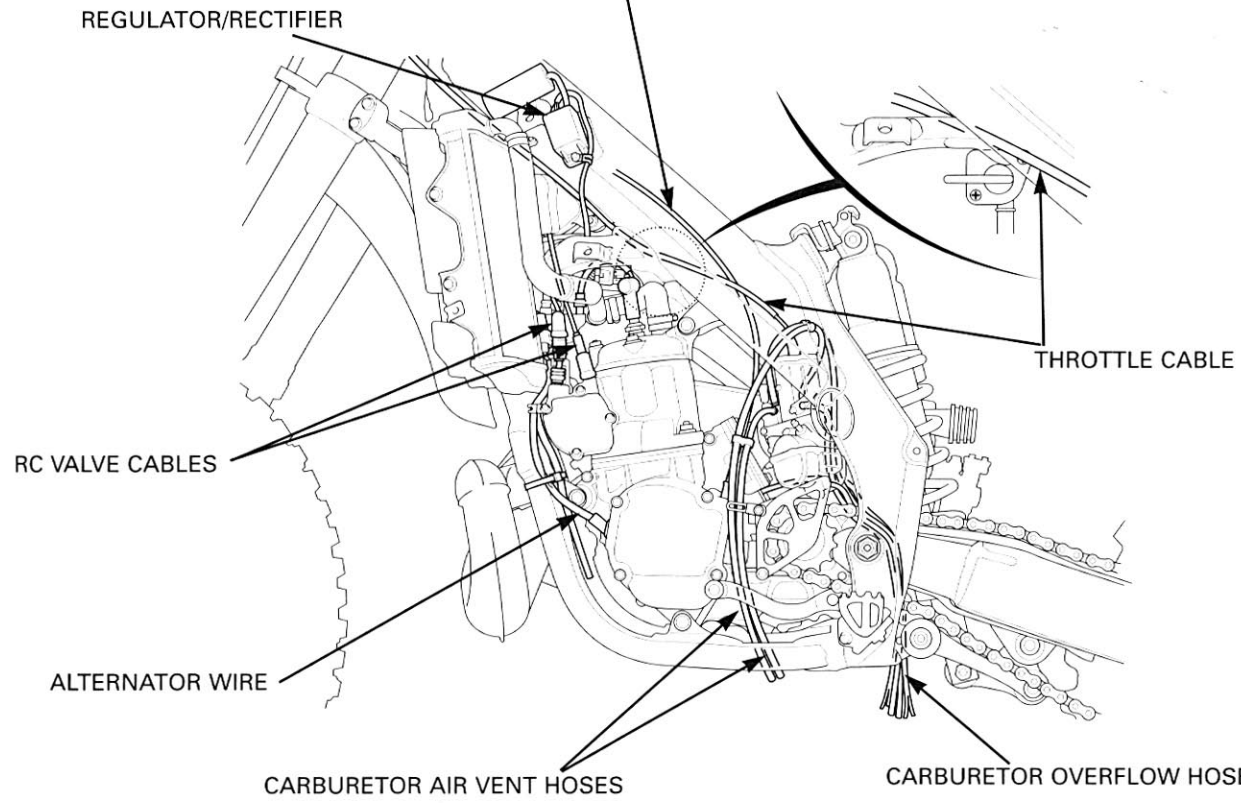

# GENERAL INFORMATION

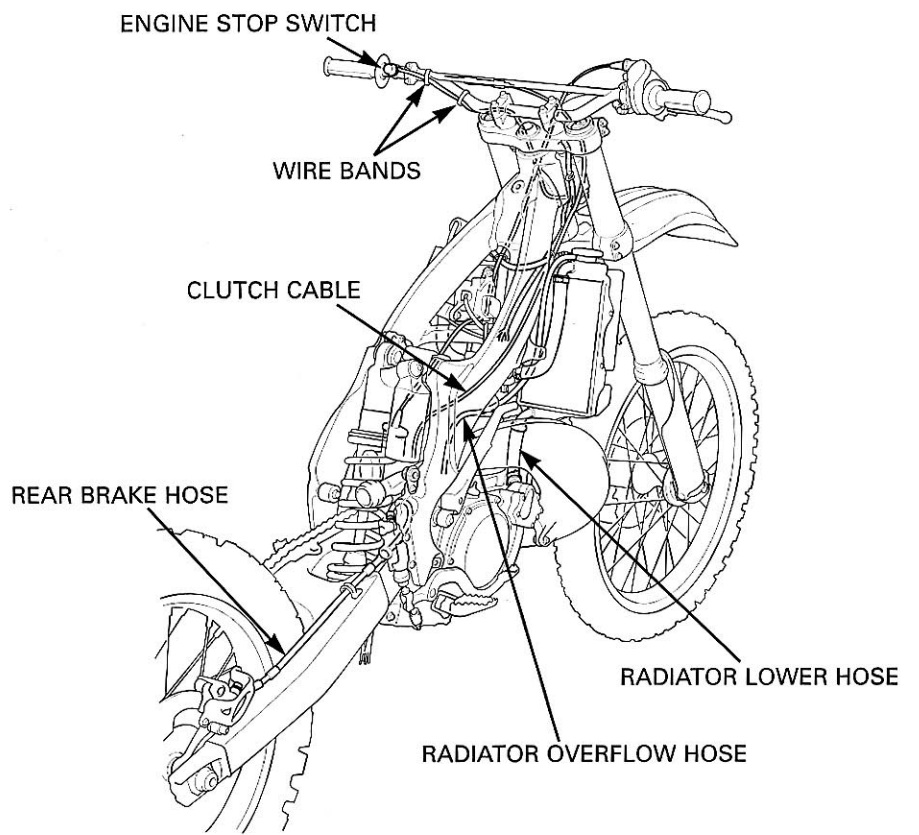
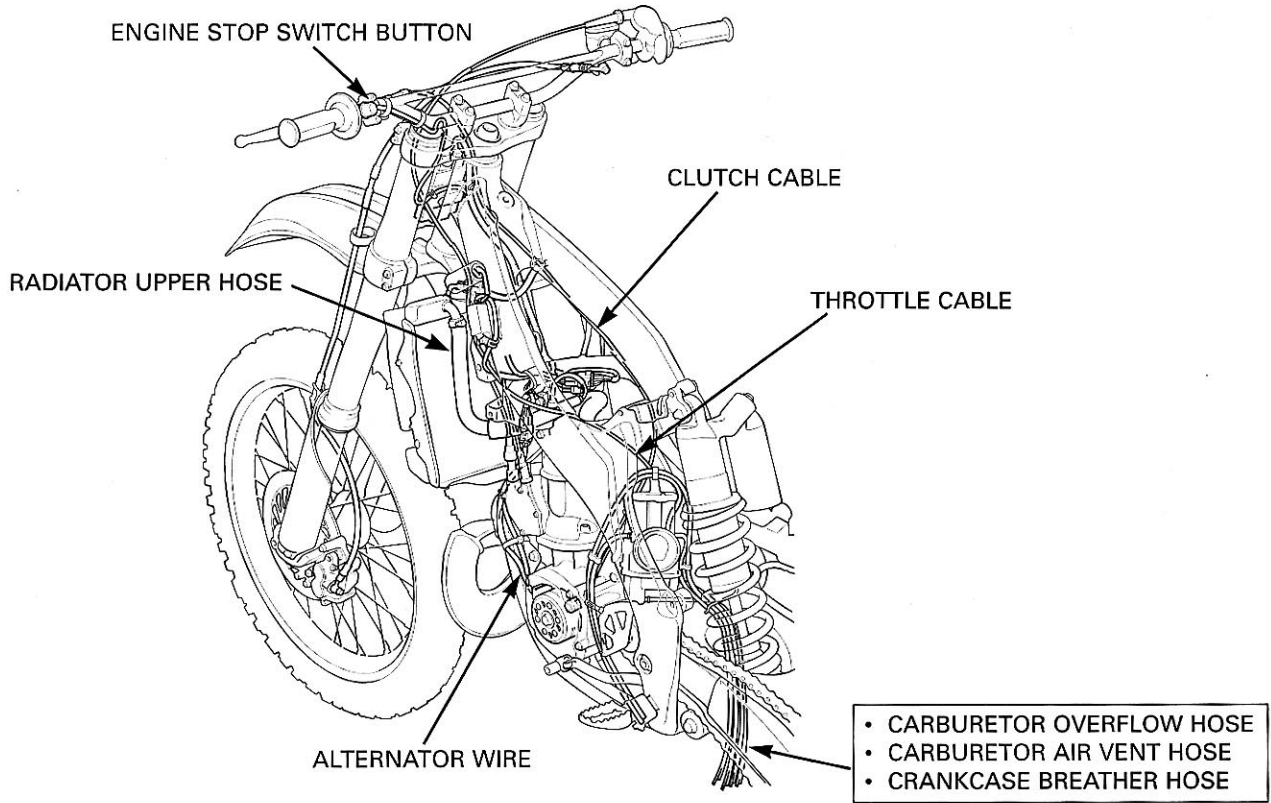

'02:

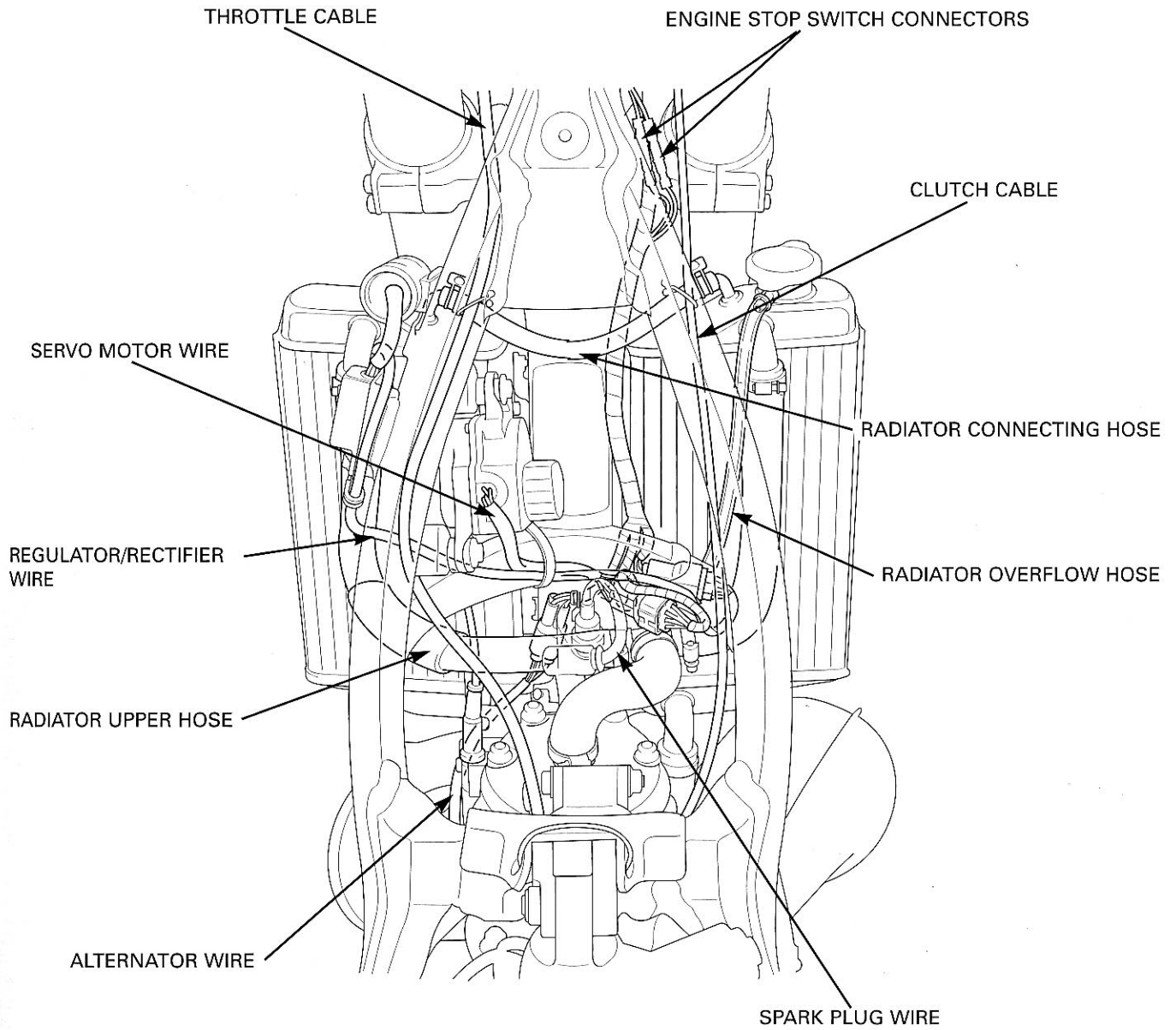

# GENERAL INFORMATION

---

AFTER '02:

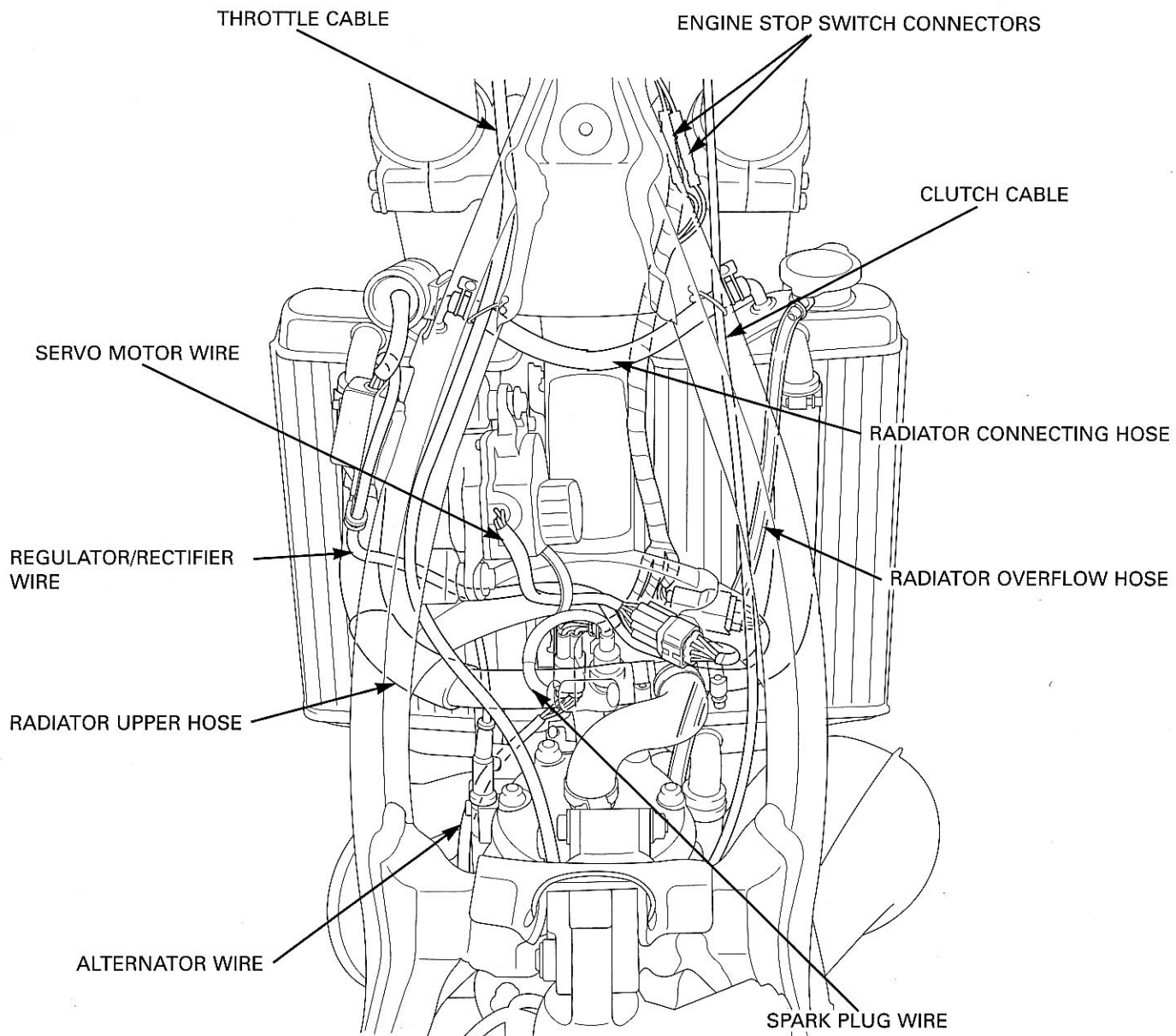

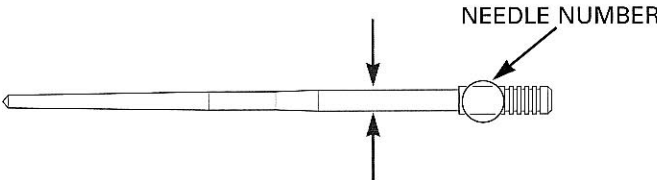

OPTIONAL PARTS

ENGINE	ITEM	REMARKS		
CARBURETOR ('02):	Main jet	Standard Optional	# 380 # 320 - 440 (increments of 10)	
	Jet needle	Standard	6BEY30-74 (ø2.740)	
		Specific flow characteristics at 1/6 to 1/4 throttle.	Jet needle number (Standard series)	Jet needle number (1/2 clip position leaner than standard series Leaner only at 1/8 to 3/4 throttle)
		Rich ↑ General flow characteristics (at 1/16 to 1/4 throttle) ↓ Lean	6BEY30-71 (ø2.710)	6BEY31-71 (ø2.710)
			6BEY30-72 (ø2.720)	6BEY31-72 (ø2.720)
			6BEY30-73 (ø2.730)	6BEY31-73 (ø2.730)
			6BEY30-74 (ø2.740) (Standard needle)	6BEY31-74 (ø2.740)
			6BEY30-75 (ø2.750)	6BEY31-75 (ø2.750)
			6BEY30-76 (ø2.760)	6BEY31-76 (ø2.760)
			6BEY30-77 (ø2.770)	6BEY31-77 (ø2.770)
		Explanation of the jet needle numbers (Example)		
	Jet needle clip standard position		2nd groove	
	Slow jet	Standard Optional	# 32.5 # 27.5 - 37.5 (increments of 2.5)	

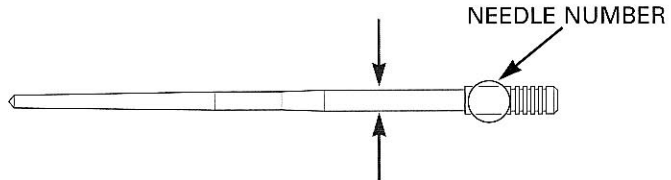
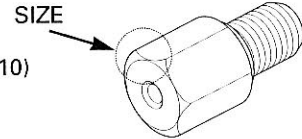



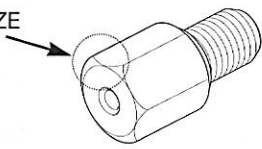
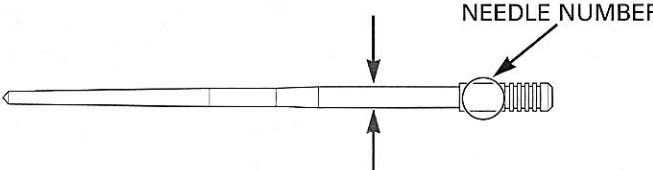

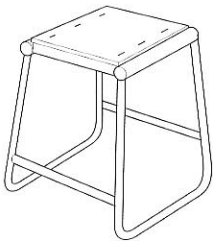
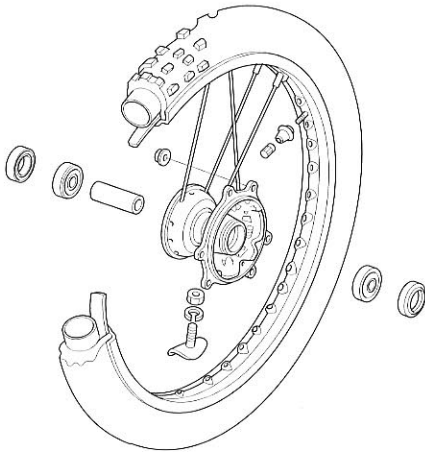

# GENERAL INFORMATION

ENGINE		ITEM	REMARKS	
<b>CARBURETOR (After '02):</b>				
Main jet	Standard Optional	# 420 # 360 - 480 (increments of 10)		
Jet needle	Standard	6BHY38-73 (ø2.730)		
	Specific flow characteristics at 1/6 to 1/4 throttle.	Jet needle number (Standard series)	Jet needle number (1/2 clip position leaner than standard series Leaner only at 1/8 to 3/4 throttle)	
Rich ↑ General flow characteristics (at 1/16 to 1/4 throttle) ↓ Lean		6BHY38-70 (ø2.700)	6BHY39-70 (ø2.700)	
		6BHY38-71 (ø2.710)	6BHY39-71 (ø2.710)	
		6BHY38-72 (ø2.720)	6BHY39-72 (ø2.720)	
		6BHY38-73 (ø2.730) (Standard needle)	6BHY39-73 (ø2.730)	
		6BHY38-74 (ø2.740)	6BHY39-74 (ø2.740)	
		6BHY38-75 (ø2.750)	6BHY39-75 (ø2.750)	
		6BHY38-76 (ø2.760)	6BHY39-76 (ø2.760)	
		Explanation of the jet needle numbers (Example) 		
	Jet needle clip standard position	2nd groove		
Slow jet	Standard Optional	# 30 # 25 - 40 (increments of 2.5)		

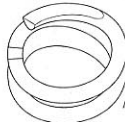



FRAME	ITEM	REMARKS
<b>MAINTENANCE:</b>	Work stand	For maintenance
Pin spanner		Pin spanner A x 2 For shock absorber spring installed length (preload) adjustment (2 required)
<b>DRIVE CHAIN &amp; SPROCKET:</b>		Driven sprocket/chain link
<b>HANDLEBAR LOWER HOLDER:</b>	Standard Optional	no offset 3 mm offset
<b>20 INCH FRONT WHEEL:</b>	<ul style="list-style-type: none"> <li>• Front wheel sub assembly               <ul style="list-style-type: none"> <li>— Rim (20 x 1.85)</li> <li>— Spoke</li> <li>— Hub</li> <li>— Distance collar</li> <li>— Wheel base</li> <li>— Dust seal</li> </ul> </li> <li>• Rim lock (1.85)</li> <li>• Tire (Dunlop D739FA 90/100-20)</li> <li>• Rim band</li> <li>• Inner tube</li> </ul>	
Front wheel assembly, see page 11-6.	<ul style="list-style-type: none"> <li>• Brake disc, disc bolts and side collars using the original parts.</li> <li>• Align the top surface of the top bridge with the top surface of the outer pipe.</li> </ul>	

## GENERAL INFORMATION

FRAME		REMARKS		
<b>FORK ('02):</b>				
Spring				
	<b>ITEM</b>	<b>TYPE</b>	<b>SPRING RATE</b>	<b>OIL CAPACITY</b>
	Light	1 scribe mark 	0.42 kgf/mm (23.52 lbf/in)	Standard 424 cm <sup>3</sup> (14.3 US oz) Maximum 446 cm <sup>3</sup> (15.1 US oz) Minimum 350 cm <sup>3</sup> (11.8 US oz)
	Standard	No mark (factory products) or 3 scribe marks (after-market parts) 	0.44 kgf/mm (24.64 lbf/in)	Standard 419 cm <sup>3</sup> (14.2 US oz) Maximum 441 cm <sup>3</sup> (14.9 US oz) Minimum 345 cm <sup>3</sup> (11.7 US oz)
	Heavy	2 scribe mark 	0.46 kgf/mm (25.76 lbf/in)	Standard 414 cm <sup>3</sup> (14.0 US oz) Maximum 436 cm <sup>3</sup> (14.7 US oz) Minimum 340 cm <sup>3</sup> (11.5 US oz)
<b>SHOCK ABSORBER ('02):</b>				
Spring				
	<b>TYPE</b>	<b>SPRING RATE</b>	<b>IDENTIFICATION MARK</b>	
	Light 	4.8 kgf/mm (268.8 lbf/in)	Black paint	
	Standard 	5.0 kgf/mm (280.0 lbf/in)	No mark (factory products) or White paint (after market parts)	
	Heavy 	5.2 kgf/mm (291.2 lbf/in) 5.4 kgf/mm (302.4 lbf/in)	Blue paint  Green paint	

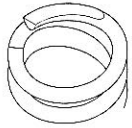
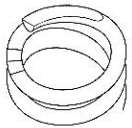
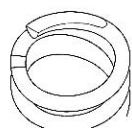
The standard fork and shock springs mounted on the motorcycle when it leaves the factory are not marked. Before replacing the springs, be sure to mark them so they can be distinguished from other optional springs.

**FRAME**

ITEM		REMARKS	
<b>FORK (After '02):</b>			
Spring			
	<b>TYPE</b>	<b>SPRING RATE</b>	<b>OIL CAPACITY</b>
Light	1 scribe mark 	0.42 kgf/mm (23.52 lbf/in)	Standard 410 cm <sup>3</sup> (13.9 US oz) Maximum 428 cm <sup>3</sup> (14.5 US oz) Minimum 332 cm <sup>3</sup> (11.2 US oz)
Standard	No mark (factory products) or 3 scribe marks (after-market parts) 	0.44 kgf/mm (24.64 lbf/in)	Standard 405 cm <sup>3</sup> (13.7 US oz) Maximum 423 cm <sup>3</sup> (14.3 US oz) Minimum 327 cm <sup>3</sup> (11.1 US oz)
Heavy	2 scribe mark 	0.46 kgf/mm (25.76 lbf/in)	Standard 400 cm <sup>3</sup> (13.5 US oz) Maximum 418 cm <sup>3</sup> (14.1 US oz) Minimum 322 cm <sup>3</sup> (10.9 US oz)
<b>SHOCK ABSORBER (After '02):</b>			
Spring			
	<b>TYPE</b>	<b>SPRING RATE</b>	<b>IDENTIFICATION MARK</b>
Light		4.9 kgf/mm (274.4 lbf/in)	Black paint
Standard		5.1 kgf/mm (285.6 lbf/in)	No mark (factory products) or White paint (after market parts)
Heavy		5.3 kgf/mm (296.8 lbf/in) 5.5 kgf/mm (308.0 lbf/in)	Blue paint  Red paint

The standard fork and shock springs mounted on the motorcycle when it leaves the factory are not marked. Before replacing the springs, be sure to mark them so they can be distinguished from other optional springs.

# 2. FRAME/BODY PANELS/EXHAUST SYSTEM

SERVICE INFORMATION	2-1	NUMBER PLATE	2-3
TROUBLESHOOTING	2-1	SUB-FRAME	2-3
SEAT	2-2	FUEL TANK	2-4
SIDE COVERS	2-2	EXHAUST PIPE	2-5
RADIATOR SHROUD	2-3		

## SERVICE INFORMATION

### GENERAL

- Work in a well ventilated area. Smoking or allowing flames or sparks in the work area or where gasoline is stored can cause a fire or explosion.
- This section covers removal and installation of the body panels, fuel tank and exhaust system.
- Always replace the exhaust pipe gaskets after removing the exhaust pipe from the engine.
- Always inspect the exhaust system for leaks after installation.

### TORQUE VALUE

Seat mounting bolt		27 N•m (2.8 kgf•m, 20 lbf•ft)
Sub-frame mounting bolt	(upper)	30 N•m (3.1 kgf•m, 22 lbf•ft)
	(lower)	30 N•m (3.1 kgf•m, 22 lbf•ft)
Seat bracket screw		4 N•m (0.4 kgf•m, 2.9 lbf•ft)
Shroud mounting bolt		6 N•m (0.6 kgf•m, 4.3 lbf•ft)

## TROUBLESHOOTING

### Excessive exhaust noise

- Broken exhaust system
- Exhaust gas leak

### Poor performance

- Deformed exhaust system
- Exhaust gas leak
- Clogged muffler

### SEAT

#### REMOVAL

Remove the two bolts, collars and seat.

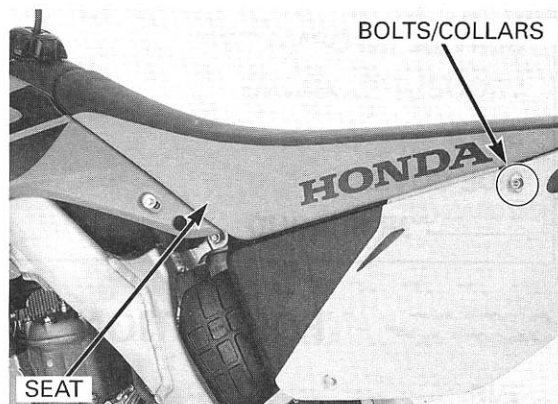

#### INSTALLATION

Align the hook of the seat with the mounting screw on the fuel tank and the seat prong with the sub-frame tab.

Install and tighten the seat mounting bolts to the specified torque.

**TORQUE: 27 N·m (2.8 kgf·m, 20 lbf·ft)**

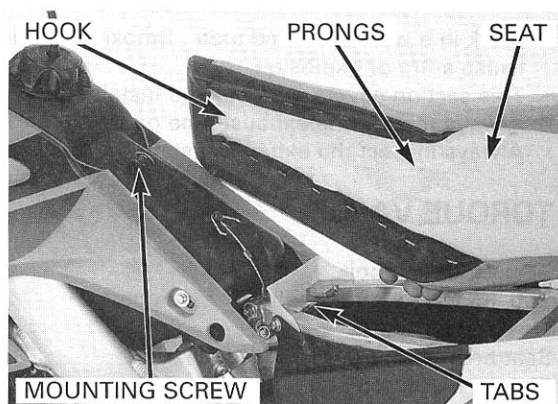

### SIDE COVERS

#### REMOVAL/INSTALLATION

Remove the seat mounting bolt and collar.  
Remove the flange bolt, collar and side cover.

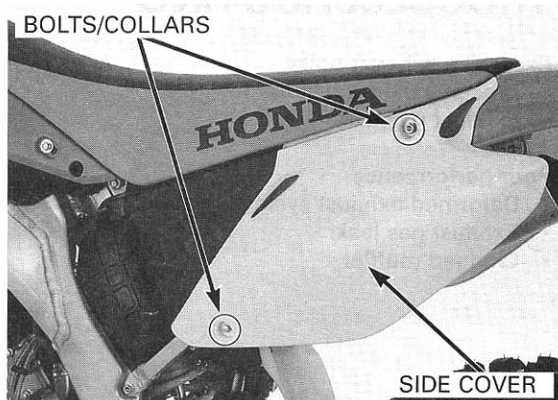

*Be careful not to damage the tabs.*

Install the side cover in the reverse order of removal.

Tighten the seat mounting bolts to the specified torque.

**TORQUE: 27 N·m (2.8 kgf·m, 20 lbf·ft)**

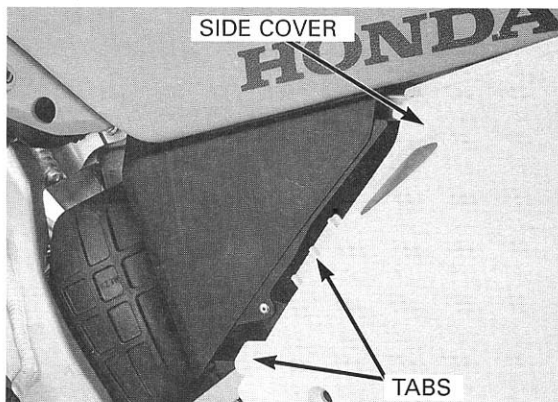

## RADIATOR SHROUD

### REMOVAL/INSTALLATION

Remove the bolt, collars and radiator shroud.

Installation is in the reverse order of removal.  
Tighten the bolts to the specified torque.

**TORQUE: 6 N·m (0.6 kgf·m, 4 lbf·ft)**

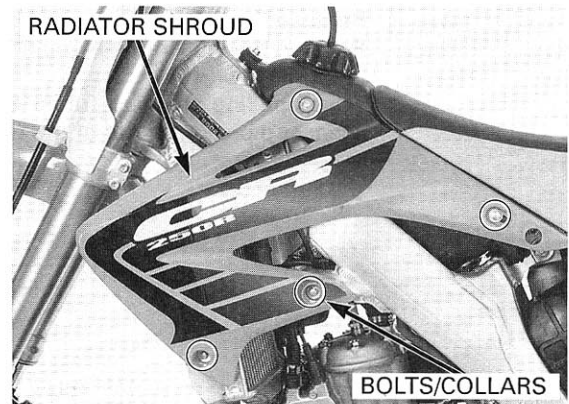

## NUMBER PLATE

### REMOVAL/INSTALLATION

Remove the number plate tab from the handlebar.  
Remove the bolt, collar and number plate.

Install the number plate aligning its hole and tab on  
the steering stem.

Installation is in the reverse order of removal.

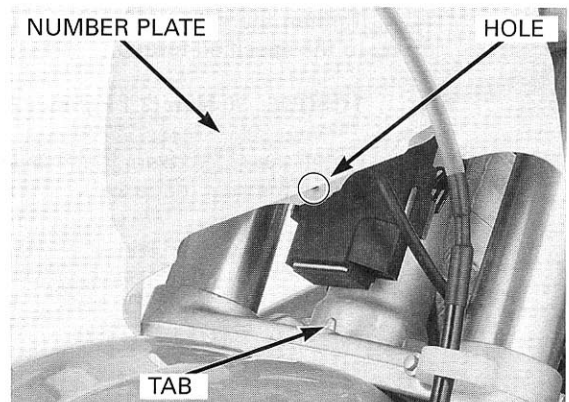
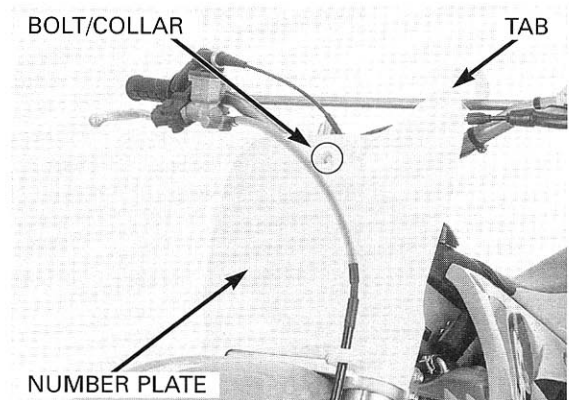

## SUB-FRAME

### REMOVAL

Remove the seat (page 2-2).  
Remove the side covers (page 2-2).

Loosen the air filter connecting boot band screw.

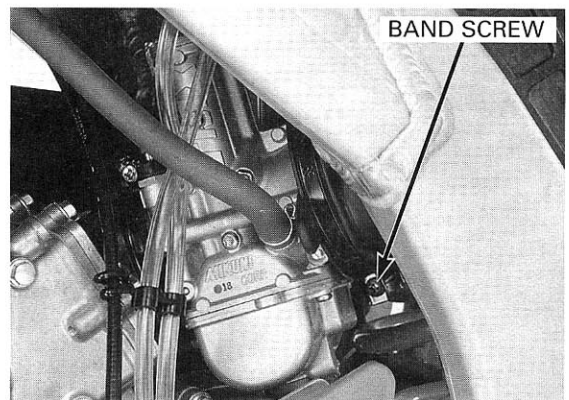



## FRAME/BODY PANELS/EXHAUST SYSTEM

Remove the three sub-frame mounting bolts.  
Remove the sub-frame by pulling it straight back.

When pulling the sub-frame back, make sure the silencer pipe comes out of the rubber seal.

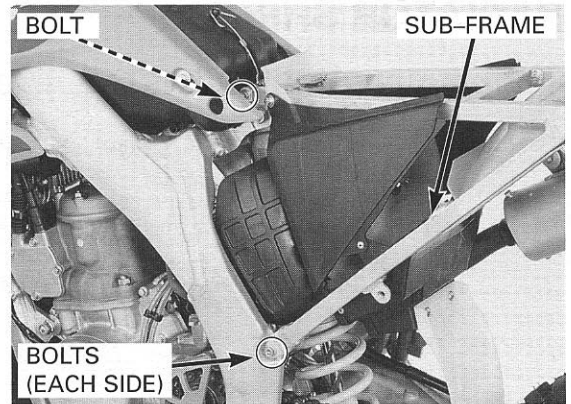

### INSTALLATION

Align the upper and lower ends of the sub-frame to the main-frame.

Install the bolts but do not tighten them.

Connect the expansion chamber to the silencer pipe (using the sealing rubber) and connect the air filter to the carburetor.

Tighten the connecting boot band screw.

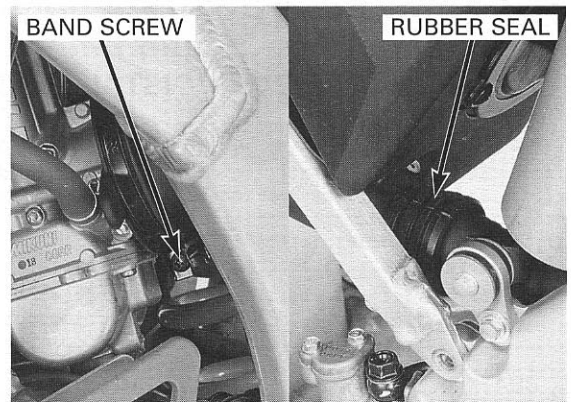

Tighten the sub-frame mounting bolts (upper/lower) to the specified torque.

**TORQUE: 30 N·m (3.1 kgf·m, 22 lbf·ft)**

Install the side covers (page 2-2).

Install the seat (page 2-2).

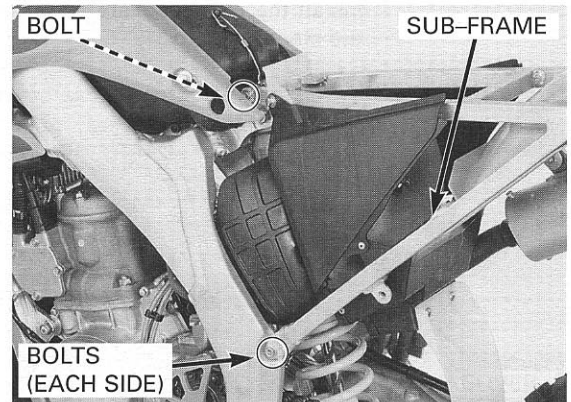

## FUEL TANK

### FUEL FILTER MAINTENANCE

Drain the fuel from the fuel tank into an approved gasoline container.

Disconnect the fuel line from the fuel valve.

Remove the bolts and fuel valve.

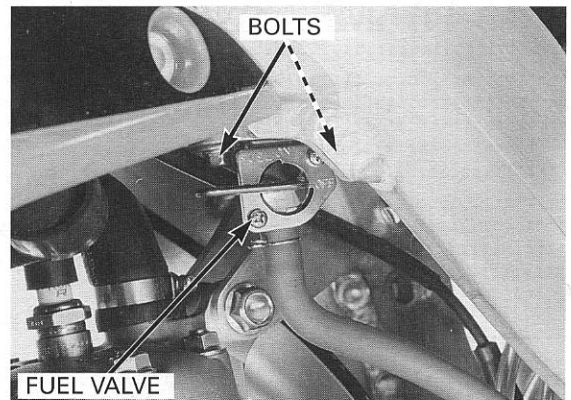

Wash the fuel filter in high flash-point cleaning solvent.

Check that the O-ring is in good condition, install it onto the fuel valve.

*After installation, make sure there are no fuel leaks.*

Install the fuel valve in the reverse order of removal.

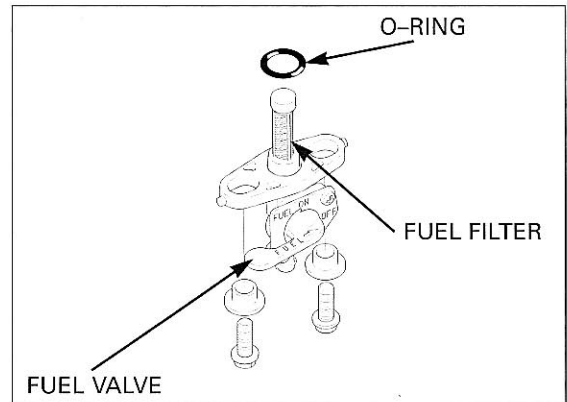

### REMOVAL/INSTALLATION

Remove the seat (page 2-2).  
Remove the radiator shrouds (page 2-3).

Turn the fuel valve to "OFF", and disconnect the fuel line.

Remove the fuel tank mounting bolts, unhook the band and remove the fuel tank.

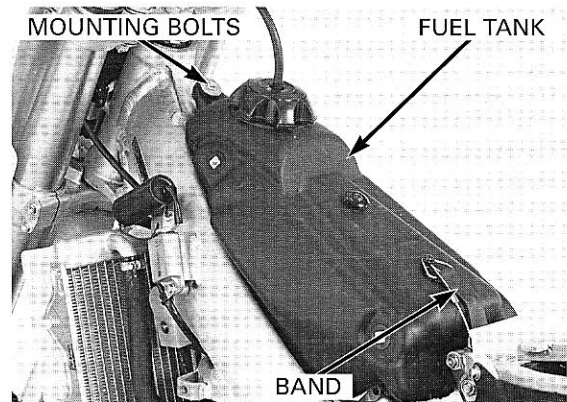

*After installation, make sure there are no fuel leaks.*

Installation is in the reverse order of removal.

Install the breather hose into the stem nut as shown.

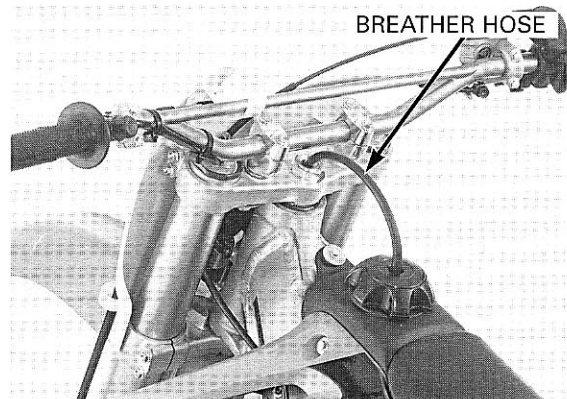

## EXHAUST PIPE

### SILENCER REMOVAL/INSTALLATION

Remove the right side cover (page 2-2).

Remove the silencer case mounting bolts, silencer case and sealing rubber.  
Check the sealing rubber for wear or damage.  
Replace the sealing rubber if necessary.

For glass wool replacement, see page 3-16.

Installation is in the reverse order of removal.

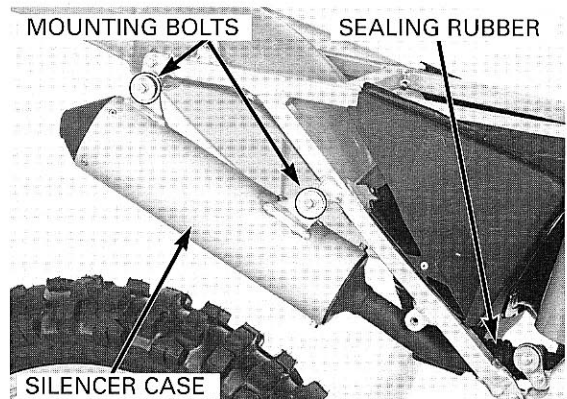

## FRAME/BODY PANELS/EXHAUST SYSTEM

### EXPANSION CHAMBER REMOVAL/INSTALLATION

Remove the seat and right side cover (page 2-2).

Loosen the chamber stay bolts and nut.

Unhook and remove the chamber springs.  
Remove the expansion chamber.

*Always replace  
the expansion  
chamber gasket  
with new ones.*

Installation is in the reverse order of removal.

Install the sealing rubber securely.

Tighten the front chamber stay nut securely.

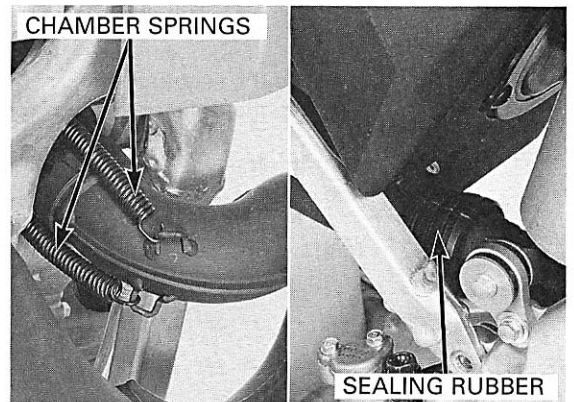
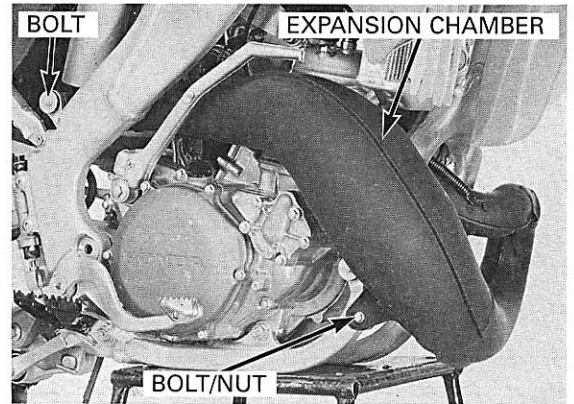

# 3. MAINTENANCE

<b>SERVICE INFORMATION</b>	<b>3-1</b>	<b>DRIVE/DRIVEN SPROCKETS</b>	<b>3-12</b>
<b>MAINTENANCE SCHEDULE</b>	<b>3-3</b>	<b>BRAKE FLUID</b>	<b>3-13</b>
<b>THROTTLE OPERATION</b>	<b>3-5</b>	<b>BRAKE PAD WEAR</b>	<b>3-14</b>
<b>AIR CLEANER</b>	<b>3-5</b>	<b>BRAKE SYSTEM</b>	<b>3-14</b>
<b>SPARK PLUG</b>	<b>3-7</b>	<b>CLUTCH SYSTEM</b>	<b>3-15</b>
<b>RADIATOR COOLANT</b>	<b>3-8</b>	<b>CONTROL CABLES</b>	<b>3-16</b>
<b>COOLING SYSTEM</b>	<b>3-8</b>	<b>EXPANSION CHAMBER/SILENCER</b>	<b>3-16</b>
<b>CYLINDER HEAD DECARBONIZING</b>	<b>3-9</b>	<b>SUSPENSION</b>	<b>3-17</b>
<b>EXHAUST VALVE AND EXHAUST VALVE LINKAGE DECARBONIZING</b>	<b>3-9</b>	<b>SWINGARM/SHOCK LINKAGE</b>	<b>3-18</b>
<b>TRANSMISSION OIL</b>	<b>3-9</b>	<b>NUTS, BOLTS, FASTENER</b>	<b>3-19</b>
<b>DRIVE CHAIN</b>	<b>3-10</b>	<b>WHEELS/TIRES</b>	<b>3-19</b>
<b>DRIVE CHAIN SLIDERS</b>	<b>3-12</b>	<b>STEERING HEAD BEARINGS</b>	<b>3-19</b>
<b>DRIVE CHAIN ROLLERS</b>	<b>3-12</b>		

## SERVICE INFORMATION

### GENERAL

- Place the motorcycle on level ground before starting any work.
- Gasoline is extremely flammable and is explosive under certain conditions.
- Work in a well ventilated area. Smoking or allowing flames or sparks in the work area or where the gasoline is stored can cause a fire or explosion.
- If the engine must be running to do some work, make sure the area is well ventilated. Never run the engine in an enclosed area.
- The exhaust contains poisonous carbon monoxide gas that may cause loss of consciousness and may lead to death. Run the engine in an open area or with an exhaust evacuation system in an enclosed area.

## MAINTENANCE

### SPECIFICATIONS

ITEM		SPECIFICATIONS
Throttle grip free play		3 – 5 mm (1/8 – 1/4 in)
Spark plug	Standard: NGK	BR8EG
	Standard: DENSO	W24ESR-V
	Option: NGK	BR8EV
	Option: DENSO	W24ESR-G
Spark plug gap		0.5 – 0.6 mm (0.020 – 0.024 in)
Transmission oil capacity	At draining	0.65 liter (0.69 US qt, 0.57 Imp qt)
	At disassembly	0.70 liter (0.74 US qt, 0.62 Imp qt)
Recommended transmission oil		Pro Honda HP Trans Oil, Pro Honda GN4, HP4 (without molybdenum additives) 4-stroke oil or equivalent motor oil API service classification: SG or higher except oils labeled as energy conserving on the circular API service label  Viscosity: SAE 10W-40 JASO T903: MA
Clutch lever free play		10 – 20 mm (3/8 – 3/4 in)
Drive chain slack		25 – 35 mm (1.0 – 1.4 in)
Chain tensioner O.D.	Upper	25 mm (0.98 in)
	Lower	39 mm (1.54 in)
Chain slider		5 mm (0.2 in)
Tire size	Front	80/100-21 51M
	Rear	110/90-19 62M
Tire air pressure	Front	100 kPa (1.0 kgf/cm <sup>2</sup> , 15 psi)
	Rear	100 kPa (1.0 kgf/cm <sup>2</sup> , 15 psi)

### TORQUE VALUES

Oil check bolt	10 N•m (1.0 kgf•m, 7 lbf•ft)
Oil drain bolt	29 N•m (3.0 kgf•m, 22 lbf•ft)
Rear axle nut	127 N•m (13.0 kgf•m, 93 lbf•ft)
Drive chain roller bolt	12 N•m (1.2 kgf•m, 9 lbf•ft)
Brake lever adjuster lock nut	5.9 N•m (0.6 kgf•m, 4.3 lbf•ft)
Spoke nipple (Front)	3.7 N•m (0.38 kgf•m, 2.7 lbf•ft)
(Rear)	3.7 N•m (0.38 kgf•m, 2.7 lbf•ft)
Rim lock	12 N•m (1.2 kgf•m, 9 lbf•ft)
Spark plug	18 N•m (1.8 kgf•m, 13 lbf•ft)
Drive chain adjusting nut	27 N•m (2.8 kgf•m, 20 lbf•ft)
Rear master cylinder joint nut	6 N•m (0.6 kgf•m, 4.3 lbf•ft)

# MAINTENANCE SCHEDULE

Perform the Pre-ride inspection in the Owner's Manual at each scheduled maintenance period.

I: Inspect and clean, adjust, lubricate or replace if necessary. C: Clean. R: Replace. A: Adjust. L: Lubricate.

ITEMS	FREQUENCY	NOTE	Each	Every 3	Every 9	REFER
			race or about 2.5 hours	races or about 7.5 hours	races or about 22.5 hours	
THROTTLE OPERATION			I			3-5
AIR CLEANER		NOTE 1	C			3-5
SPARK PLUG			I	R		3-7
RADIATOR COOLANT		NOTE 2	I			3-8
COOLING SYSTEM			I			3-8
CYLINDER HEAD DECARBONIZING				C		3-9
EXHAUST VALVE AND EXHAUST VALVE LINKAGE DECARBONIZING				C		3-9
PISTON AND PISTON RINGS				R		7-9
PISTON PIN AND CONNECTING ROD SMALL END BEARING					R	7-7,8,9
REED VALVE				R		4-16
TRANSMISSION OIL				R		3-9
DRIVE CHAIN			I, L	R		3-10
DRIVE CHAIN SLIDERS			I			3-12
DRIVE CHAIN ROLLERS			I			3-12
DRIVE SPROCKET			I			3-12
DRIVEN SPROCKET			I			3-12
BRAKE FLUID		NOTE 2	I			3-13
BRAKE PAD WEAR			I			3-14
BRAKE SYSTEM			I			3-14
CLUTCH SYSTEM			I			3-15
CONTROL CABLES			I, L			3-16
EXPANSION CHAMBER/SILENCER			I			3-16
SUSPENSION			I			3-17
SWINGARM/SHOCK LINKAGE				L		3-18 12-25,31
FORK OIL	FORK PIPE/SLIDER	NOTE 3		R		11-25
	FORK DAMPER				R	11-18
NUTS, BOLTS, FASTENERS			I			3-19 1-12
WHEELS/TIRES			I			3-19
STEERING HEAD BEARINGS					I	3-29

This maintenance schedule is based upon average riding conditions. Machines subjected to severe use require more frequent servicing.

- NOTES:
1. Clean after every moto for dusty riding conditions.
  2. Replace every 2 years. Replacement requires mechanical skill.
  3. Replace after the first break-in ride.

## MAINTENANCE

### ADDITIONAL ITEMS REQUIRING FREQUENT REPLACEMENT

ENGINE		
ITEM	CAUSE	REMARKS
Cylinder head gasket	Compression leak	Replace whenever disassembled
Clutch disc	Wear or discoloration	
Cylinder base gasket	Leakage	Replace whenever disassembled
Right crankcase cover gasket	Damage	Replace whenever disassembled
RC valve cover gasket	Damage	

FRAME		
ITEM	CAUSE	REMARKS
Front/rear tire	Wear	Minimum cleat height: 8mm (5/16 in)
Front/Rear brake pad	Wear	Minimum thickness: 1 mm (0.04 in)
Sub-frame mounting bolts	Fatigue or damage	
Drive chain guide plate	Wear or damage	
Side cover	Damage	
Front number plate	Damage	
Front/rear fender	Damage	
Clutch lever/holder	Play or damage	
Brake lever	Play or damage	
Handlebar	Bent or cracked	
Throttle housing	Damage	
Grip rubber	Damage	
Gearshift pedal	Damage	
Brake pedal	Damage	
Drive chain adjuster/bolt	Damage	
Air cleaner	Damage	
Exhaust chamber spring/hook	Fatigue or damage	

NOTE: These parts and their possible replacement schedule are based upon average riding conditions. Machines subjected to severe use require more frequent servicing.

## THROTTLE OPERATION

Check for smooth throttle grip full opening and automatic full closing in all steering positions. Check the throttle cables and replace them if they are deteriorated, kinked or damaged. Lubricate the throttle cables, if throttle operation is not smooth.

Measure the free play at the throttle grip flange.

**FREE PLAY: 3 – 5 mm (1/8 – 1/4 in)**

Throttle grip free play can be adjusted at either end of the throttle cable.

Minor adjustments are made with the upper adjuster. Remove the dust cover from the adjuster. Adjust the free play by loosening the lock nut and turning the adjuster.

Tighten the lock nut after making the adjustment. Reinstall the dust cover.

Major adjustments are made with the carburetor end of the cable.

Pull the carburetor rubber cap up. Adjust the free play by loosening the lock nut and turning the adjuster.

After adjustment, tighten the lock nut securely and reinstall the rubber cap. Recheck the throttle operation.

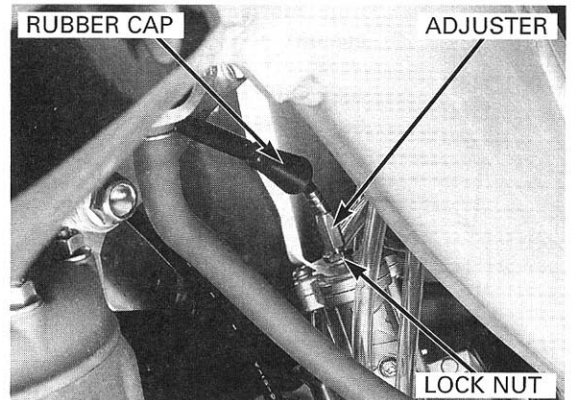
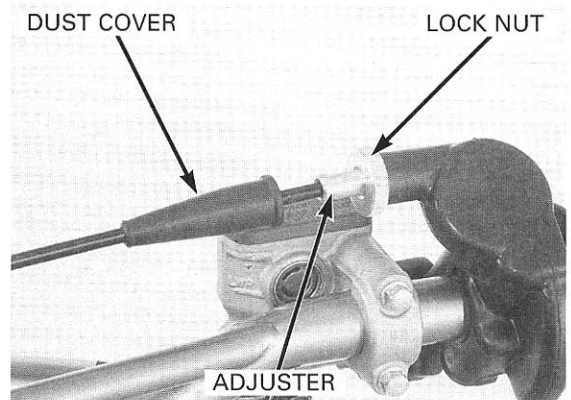
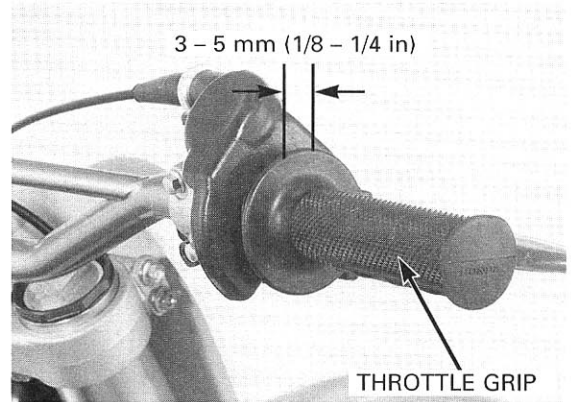

## AIR CLEANER

Remove the seat (page 2-2).

Loosen the air cleaner retaining bolt.

Remove the air cleaner assembly.

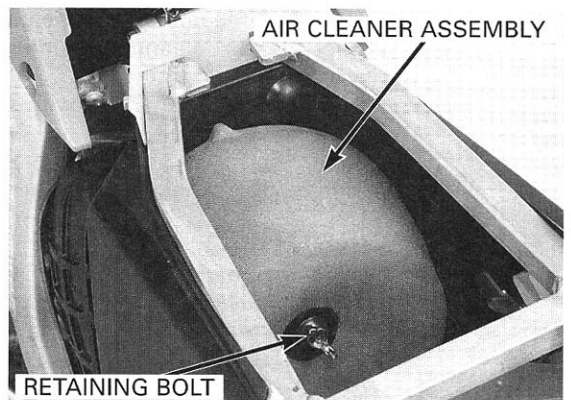



## MAINTENANCE

Remove the air cleaner from the cleaner holder.

*Never use gasoline or low flash point solvents for cleaning the air filter element. A fire or explosion could result.*

Thoroughly wash the air cleaner in clean non-flammable or high flash-point cleaning solvent. Then wash the element again in a solution of hot water and dishwashing liquid soap. Clean the inside of the air cleaner housing.

After cleaning, be sure there is no dirt or sand trapped between the inner and outer layer of the cleaner. Wash again if necessary.

Allow the air cleaner to dry thoroughly. After drying, soak the air cleaner in clean Honda Foam Filter Oil or an equivalent.

Apply air filter oil to the entire surface of the air cleaner and rub it with both hands to saturate the element with oil. Gently squeeze out excess oil. It is important not to over-oil, or under-oil the element.

Apply a thin coat of Honda White Lithium Grease or an equivalent to the sealing surface.

Assemble the air cleaner onto the holder. Set the air cleaner/holder to the housing until the position as shown.

'02: Slip the air cleaner retaining bolt through the assembly.

Align the air cleaner tab with the "Δ" mark on the housing and install it.

Tighten the retaining bolt securely.

After '02: Install the air cleaner/holder to the housing aligning the tab on the holder with the groove on the housing. Slip the air cleaner retaining bolt through the assembly.

Align the air cleaner tab with the "Δ" mark on the housing and install it.

Tighten the retaining bolt securely.

### NOTICE

*If the air cleaner assembly is not installed correctly, dirt and dust may enter the engine resulting in wear of the piston ring and cylinder.*

Install the seat (page 2-2).

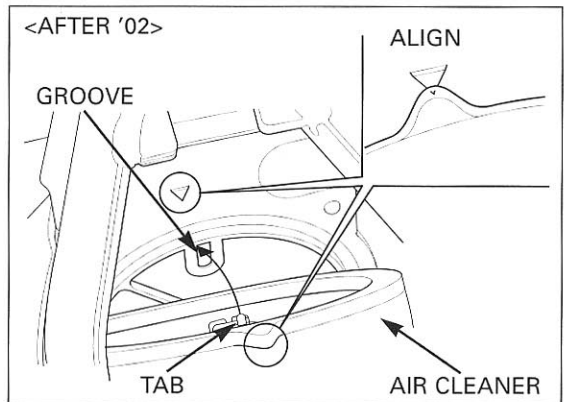
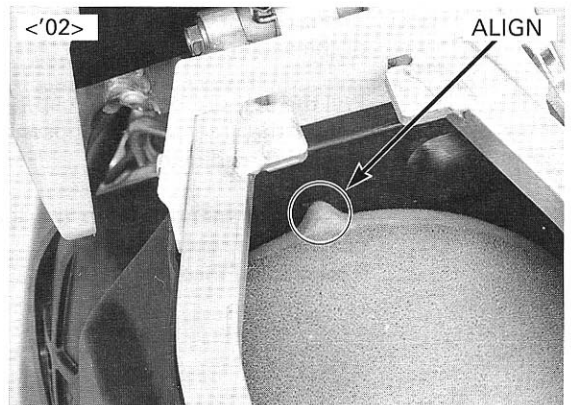
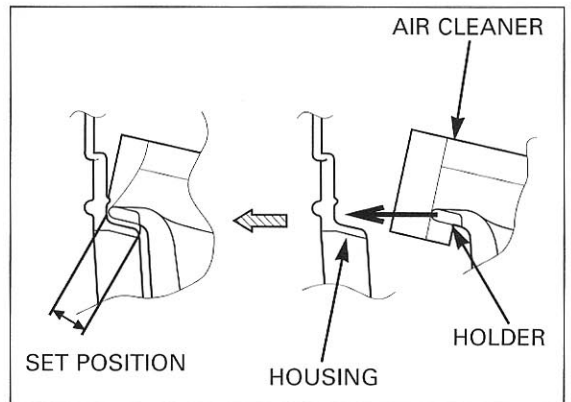
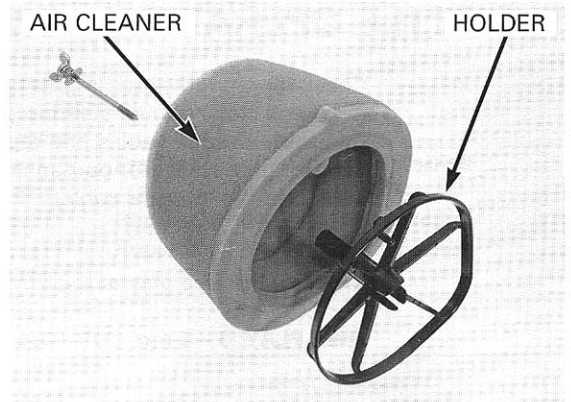

# SPARK PLUG

Disconnect the spark plug cap.

Clean around the spark plug bases with compressed air before removing, and be sure that no debris is allowed to enter the combustion chamber.

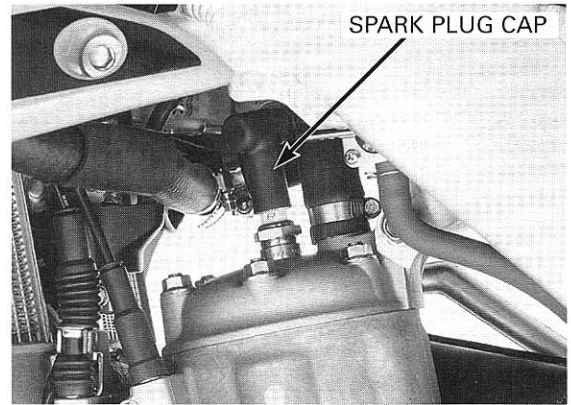

Remove the spark plug and inspect it for damage.

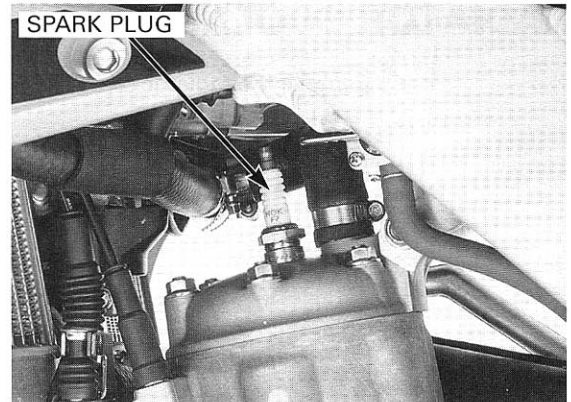

Check the following and replace if necessary (recommended spark plug: page 3-2)

- Insulator for damage
- Electrodes for wear
- Burning condition, coloration;
  - Dark to light brown indicates good condition.
  - Excessive lightness indicates malfunctioning ignition system or lean mixture.
  - Wet or black sooty deposit indicates over-rich mixture.

**RECOMMENDED SPARK PLUG (OR EQUIVALENT)**  
**NGK: Standard [Optional]: BR8EG [BR8EV]**  
**DENSO: Standard [Optional]: W24ESR-V [W24ESR-G]**

If necessary, adjust the gap by carefully bending the side electrode. Then, measure the gap again and reinstall.

**SPARK PLUG GAP: 0.5 – 0.6 mm (0.020 – 0.024 in)**

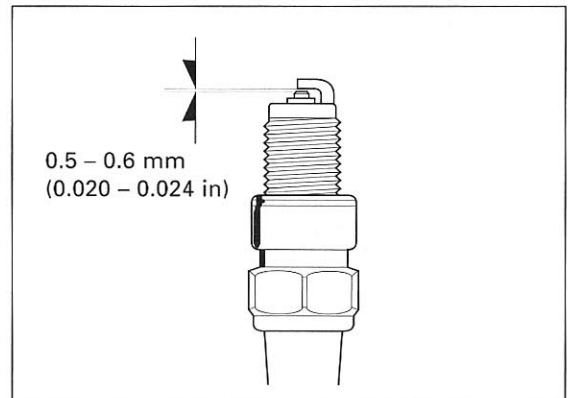
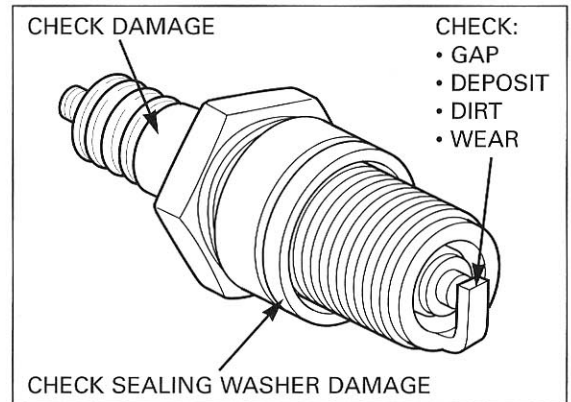

## MAINTENANCE

*To prevent damage to the cylinder head, hand-tighten the spark plug before using a wrench to tighten to the specified torque.*

Reinstall the spark plugs in the cylinder head and hand tighten, then torque to specification.

**TORQUE: 18 N•m (1.8 kgf•m, 13 lbf•ft)**

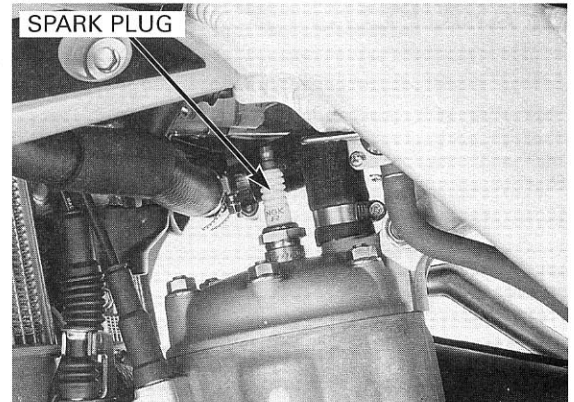

## RADIATOR COOLANT

Remove the radiator cap.

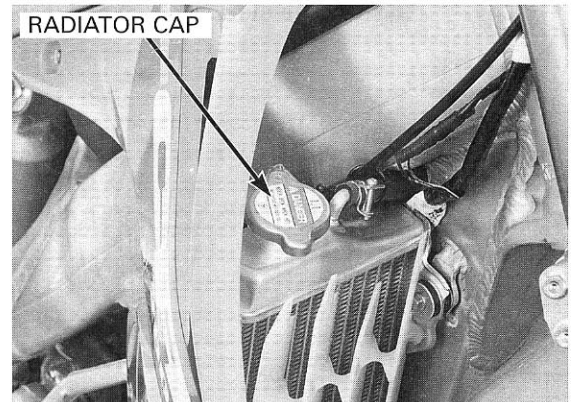

Check the coolant level with the engine cold, it should be up to the filler neck.

Add coolant as required (page 5-4).

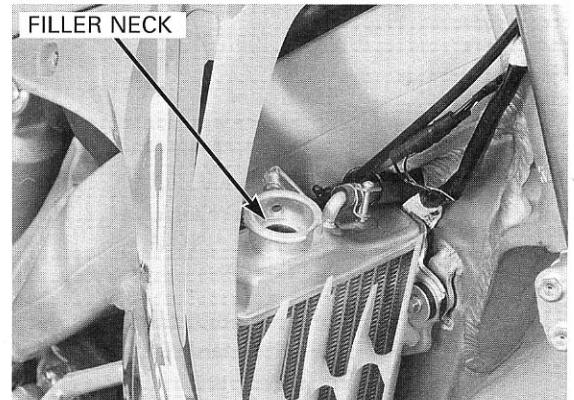

## COOLING SYSTEM

Remove the radiator shrouds (page 2-3).

Check the radiator air passage for clogs or damage. Inspect the hoses for cracks and deterioration.

Use low pressure water and a soft brush to rinse off any dirt that may be stuck in the radiator core. Inspect the hoses for cracks and deterioration. Replace if necessary. Check the tightness of the hose clamps and radiator mounting bolts.

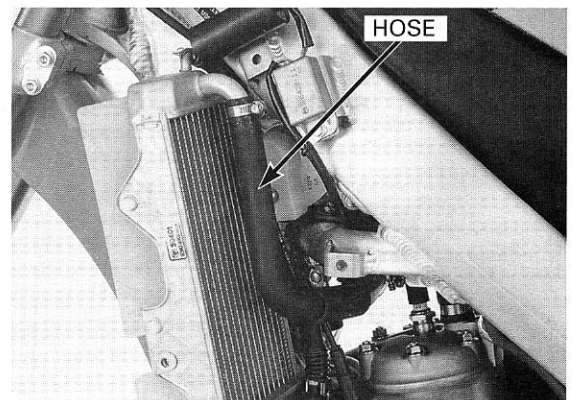

## CYLINDER HEAD DECARBONIZING

Remove the cylinder head (page 7-3).

*Be careful not to damage the cylinder head.*

Clean the head gasket surface of any gasket material. Remove the carbon deposits from the combustion chamber.

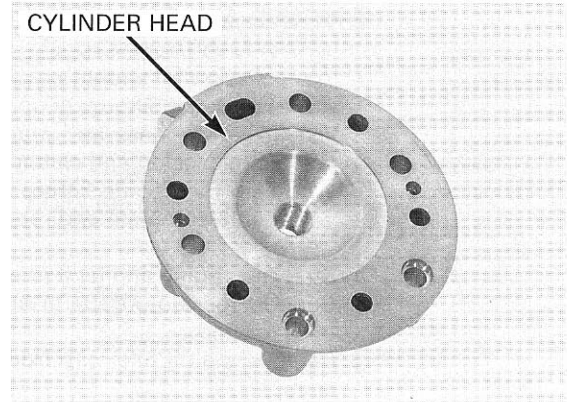

## EXHAUST VALVE AND EXHAUST VALVE LINKAGE DECARBONIZING

Remove the flap valves and flap valve shaft (page 8-4).

*Decarbonize the flap valves and flap valve shaft after every race.*

Remove the carbon deposits from the flap valves and flap valve shaft. Inspect the flap valves and flap valve shaft for wear or damage.

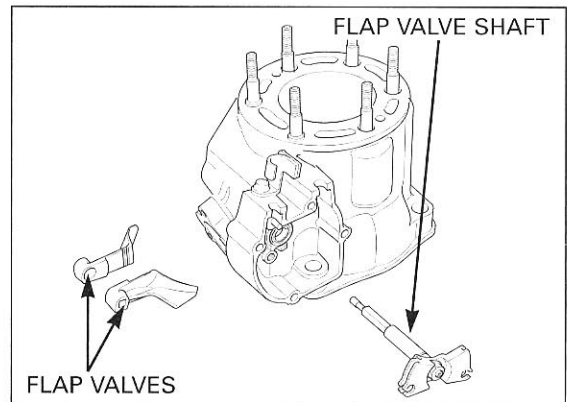

## TRANSMISSION OIL

### OIL LEVEL INSPECTION

1. Start the engine and let it idle for 2 – 3 minutes.
2. Wait 3 minutes after shutting off the engine to allow the oil to properly distribute itself in the clutch and transmission.
3. Support the motorcycle in an upright position on level ground.
4. Remove the oil filler cap and check bolt from the right crankcase cover. A small amount of oil should flow out of the check bolt hole. Allow any excess oil to flow out of the check bolt hole.
5. If no oil flows out of the check bolt hole, add oil slowly through the oil filler hole until oil starts to flow out of the check bolt hole. Install the oil check bolt and filler cap.
6. Repeat steps 1 – 4.
7. After checking the oil level or adding oil, tighten the oil check bolt and filler cap securely.

**TORQUE: 10 N·m (1.0 kgf·m, 7 lbf·ft)**

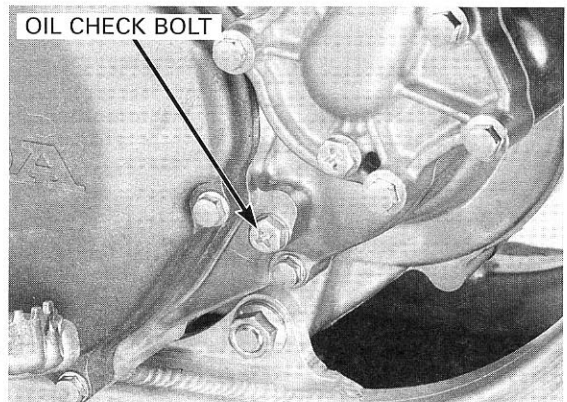
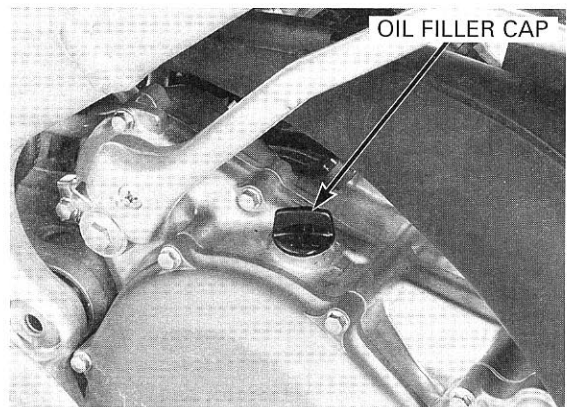

## ENGINE OIL CHANGE

- Transmission oil should be changed at least every three races or 7.5 hours of operation to ensure consistent performance and maximum service life of both transmission and clutch components.
- Warm-up the engine before draining the oil. This will ensure complete and rapid draining.

1. Start the engine and let it idle for 2 – 3 minutes.
2. Support the motorcycle in an upright position on level ground.
3. Remove the oil filler cap from the right crankcase cover.
4. Place an oil pan under the engine to catch the oil, then remove the drain bolt.
5. After the oil has drained completely, install the drain bolt with a new sealing washer.

**TORQUE: 29 N·m (3.0 kgf·m, 22 lbf·ft)**

6. Add the recommended oil.

### OIL CAPACITY:

**0.65 liter (0.69 US qt, 0.57 Imp qt) at draining**

**0.70 liter (0.74 US qt, 0.62 Imp qt) at disassembly**

### RECOMMENDED ENGINE OIL:

**Pro Honda HP Trans oil, Pro Honda GN4, HP4 (without molybdenum additives) 4-stroke oil or equivalent motor oil**

**API service classification: SG or higher except oils labeled as energy conserving on the circular API service label**

**Viscosity: 10W-40**

**JASO T903: MA**

Check the oil level by following steps 1 – 6 in the oil level check procedure (page 3-9).

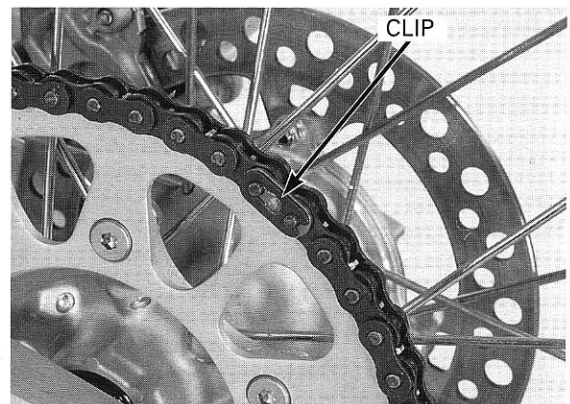
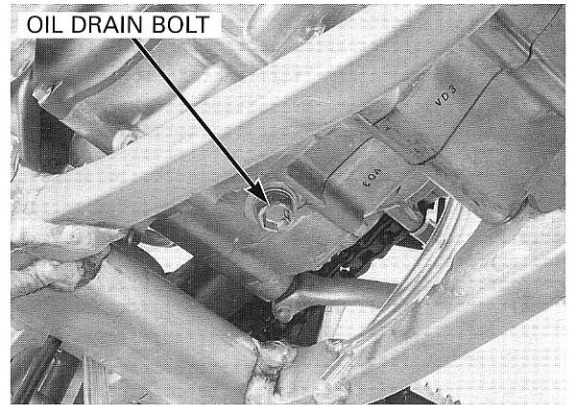

## DRIVE CHAIN

*Never inspect and adjust the drive chain while the engine is running.*

For maximum service life, the drive chain should be cleaned and lubricated after each ride.

Perform the following service with the engine stopped and the transmission in neutral.

Place a workstand under the engine.

Carefully remove the master link clip with pliers. Remove the master link and the drive chain.

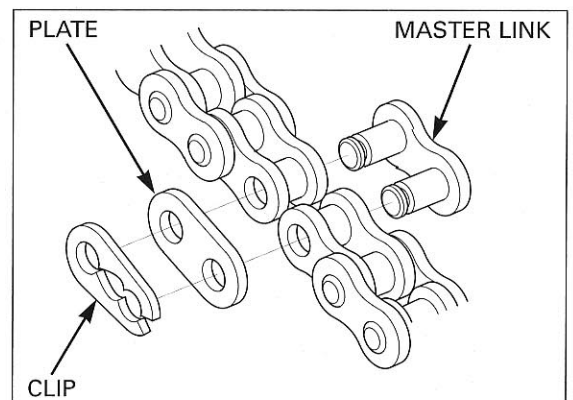

Clean the drive chain in non-flammable or high flash-point solvent and wipe it dry.

Inspect the chain for possible wear or damage; replace any chain that has damaged rollers or loose fitting links.

Reinstall the drive chain and lubricate it with Pro Honda Chain Lube or its equivalent.

Install the open end of the master link opposite the direction of chain travel.

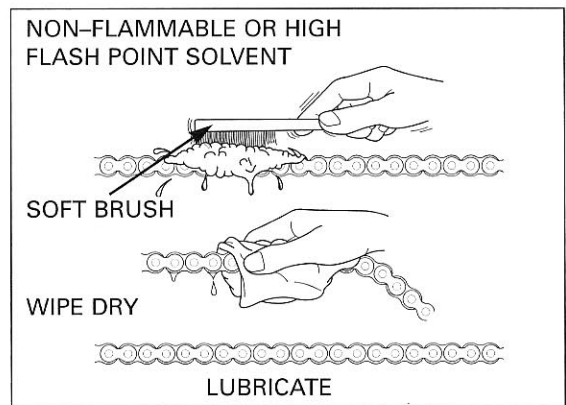

Measure the distance between a span of 17 pins (16 pitches), from pin center to pin center.

**SERVICE LIMIT: 259 mm (10.20 in)**

If the measurement exceeds the service limit, replace the chain.

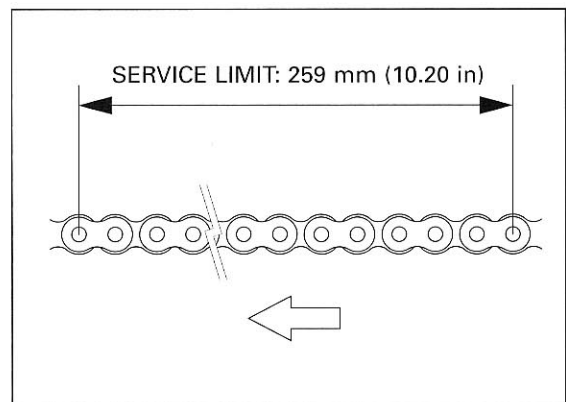

**ADJUSTMENT**

Raise the rear wheel off the ground by placing a work-stand under the engine.

Measure the chain slack, in the upper chain run, midway between the sprockets.

**CHAIN SLACK: 25 – 35 mm (1.0 – 1.4 in)**

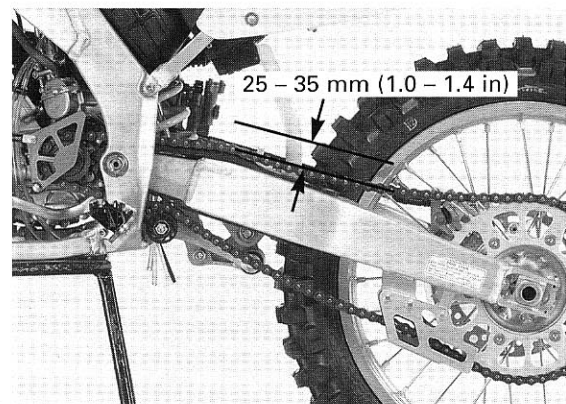

If the chain needs adjustment, loosen the axle nut and adjuster lock nuts, and turn the adjusting bolts.

Check that the chain adjuster index marks are in the same position on each side, then tighten the axle nut to the specified torque.

**TORQUE: 127 N·m (13.0 kgf·m, 93 lbf·ft)**

After torquing the axle nut, seat the adjusting bolts snugly against the axle adjustment plates and tighten the adjuster lock nut to the specified torque.

**TORQUE: 27 N·m (2.8 kgf·m, 20 lbf·ft)**

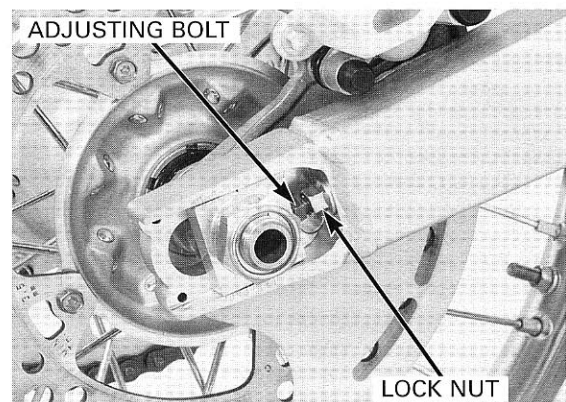

**DRIVE CHAIN SLIDERS**

Inspect the drive chain slider for excessive wear.

**SERVICE LIMIT: 5 mm (0.2 in) from upper surface**

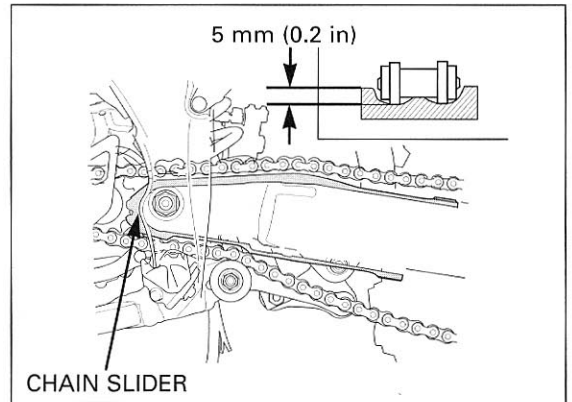

Check the chain guide and chain guide slider for alignment, wear or damage.

Replace the chain guide if it is damaged or worn.

Replace the chain guide slider if the chain visible through the wear inspection window.

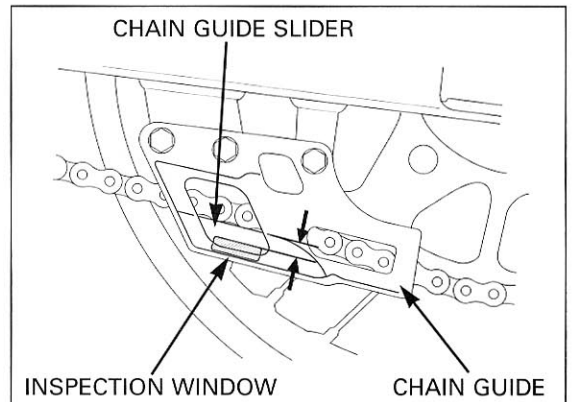

**DRIVE CHAIN ROLLERS**

Inspect the drive chain rollers for excessive wear or binding.

**SERVICE LIMIT: Minimum roller O.D.:**  
**Upper: 25 mm (0.98 in)**  
**Lower: 39 mm (1.54 in)**

Replace the roller if necessary.  
 Install the drive chain rollers as follows:

- Upper: Orange oil seal
- Lower: Black oil seal

Tighten the roller bolt/nut to the specified torque (page 12-30).

**TORQUE: 12 N·m (1.2 kgf·m, 9 lbf·ft)**

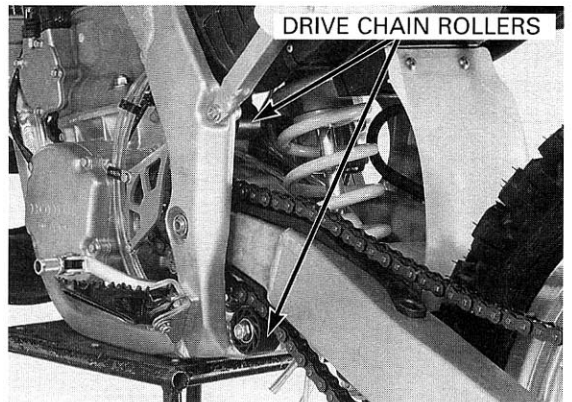

**DRIVE/DRIVEN SPROCKETS**

*Never use a new drive chain on worn sprockets.*

Inspect the drive and driven sprocket teeth for wear or damage, replace if necessary.

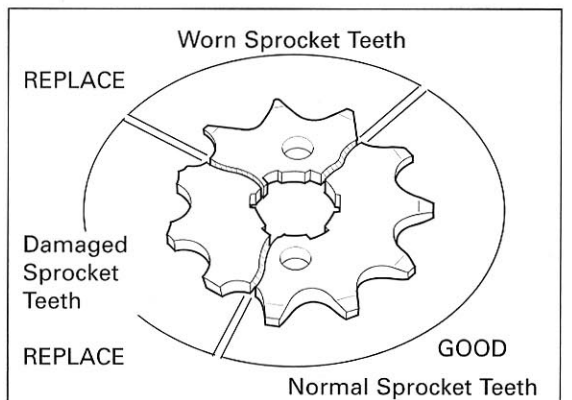

## BRAKE FLUID

### NOTICE

- Do not mix different types of fluid, as they are not compatible with each other.
- Do not allow foreign material to enter the system when filling the reservoir.
- Avoid spilling fluid on painted, plastic or rubber parts. Place a rag over these parts whenever the system is serviced.

### FLUID LEVEL INSPECTION

When the fluid level is low, check the brake pads for wear (see next page). A low fluid level may be due to wear of the brake pads. If the brake pads are worn, the caliper piston is pushed out, and this accounts for a low reservoir level. If the brake pads are not worn and the fluid level is low, check the entire system for leaks (see next page).

#### FRONT BRAKE:

Check the front brake fluid reservoir level through the sight glass.

If the level is near the lower level mark, check the brake pad wear (page 3-14).

#### REAR BRAKE:

Place the motorcycle on a level surface, and support it in an upright position.

Check the rear brake fluid reservoir level.

If the level is near the lower level line, check the brake pad wear (page 3-14).

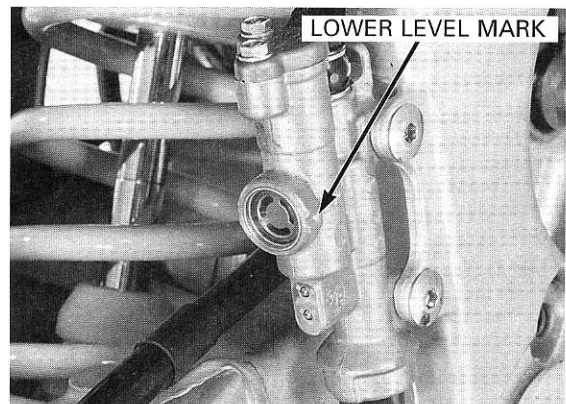
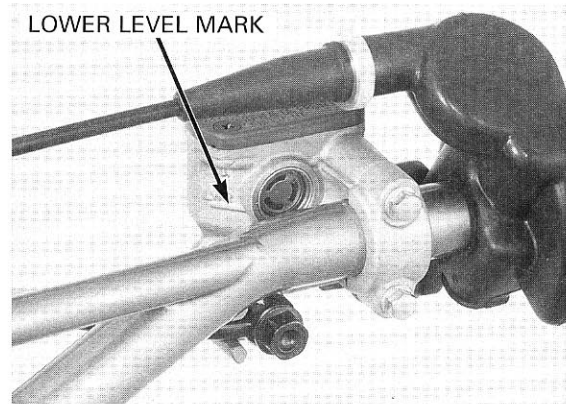

### FLUID FILLING

#### FRONT:

Remove the screws, cover and diaphragm. Fill the reservoir with DOT 4 brake fluid to the upper level mark. Install the diaphragm and cover. Tighten the screws to the specified torque.

**TORQUE: 1.0 N·m (0.1 kgf·m, 0.7 lbf·ft)**

Check the entire system for leaks.

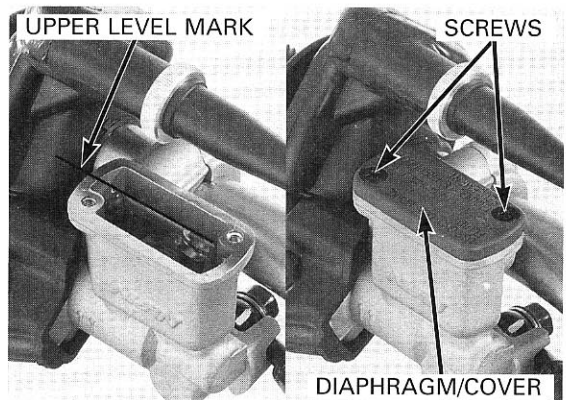



## MAINTENANCE

### REAR:

Remove the bolts, cover and diaphragm.  
Fill the reservoir with DOT 4 brake fluid to the upper level mark.

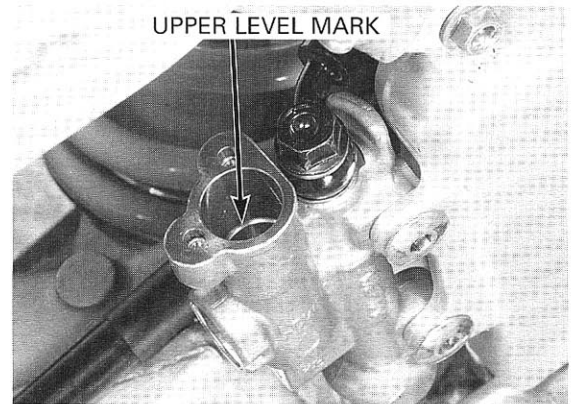

Straighten the diaphragm and install the diaphragm to the rear master cylinder.  
Check the diaphragm installation as shown.  
Install the cover.  
Tighten the bolts to the specified torque.

**TORQUE: 1.0 N•m (0.1 kgf•m, 0.7 lbf•ft)**

Check the entire system for leaks.

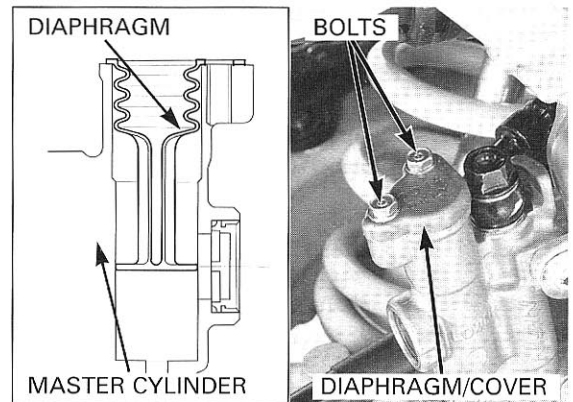

## BRAKE PAD WEAR

Check the brake pad for wear.  
Replace the brake pads if either pad is worn to the bottom of the wear limit groove.

Refer to page 13-7 for brake pad replacement.

## BRAKE SYSTEM

### LEVER POSITION INSPECTION

The brake lever position can be adjusted by loosening the lock nut and turning the adjuster.

Turning the adjuster clockwise moves the brake lever farther away from the grip; turning the adjuster counterclockwise moves the brake lever closer to the grip. After adjustment, hold the adjuster and tighten the lock nut to the specified torque.

**TORQUE: 5.9 N•m (0.6 kgf•m, 4.3 lbf•ft)**

If the brake lever free play exceeds 20 mm (0.8 in), there is air in the system that must be bled. Refer to page 13-4 for brake system bleeding.

Apply grease to the contact faces of the adjuster bolt and piston.

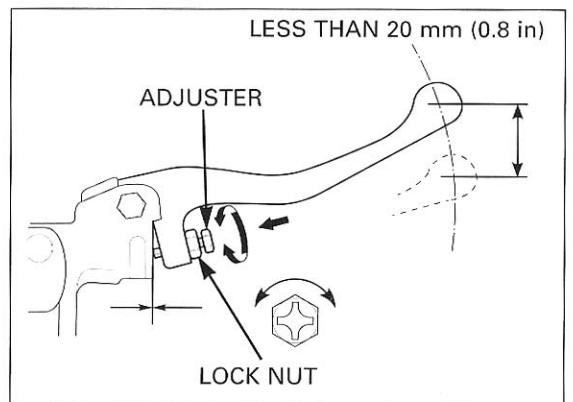
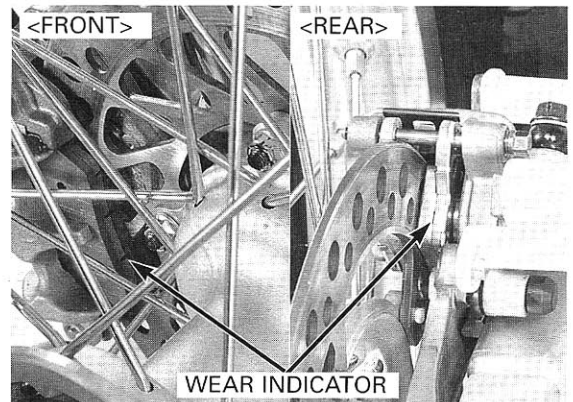

## BRAKE PEDAL HEIGHT

Adjust the brake pedal to the desired height by loosening the lock nut and turning the pedal height adjusting bolt.

Tighten the lock nut to the specified torque.

**TORQUE: 6 N·m (0.6 kgf·m, 4.3 lbf·ft)**

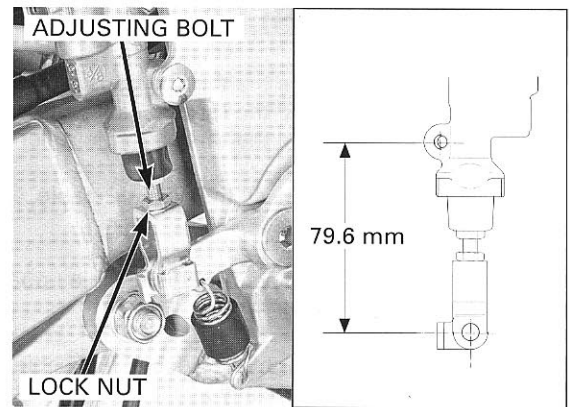

## CLUTCH SYSTEM

Measure the clutch free play at the lever end.

**FREE PLAY: 10 – 20 mm (3/8 – 3/4 in)**

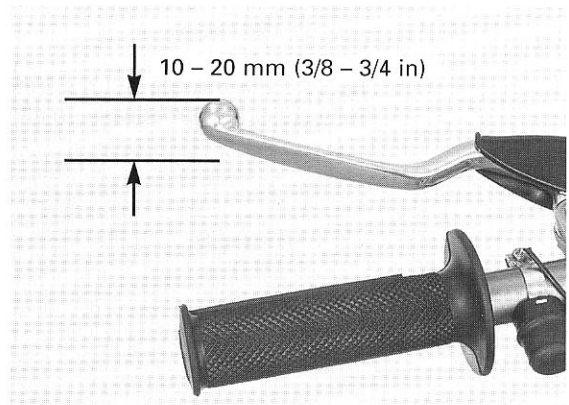

Minor adjustments are made at the adjuster on the lever.

Pull the cover back.  
Loosen the lock nut and turn the adjuster.

Tighten the lock nut.

If the adjuster is threaded out near its limit and correct free play cannot be obtained, turn the adjuster all the way in and then back it out one turn.

Tighten the lock nut, install the dust cover and make a major adjustment, as follows.

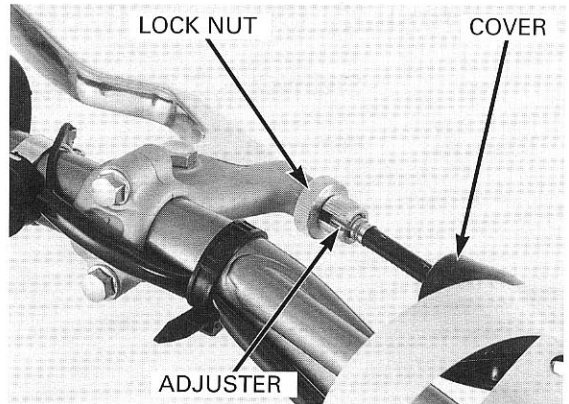

Major adjustments are made with the in-line cable adjuster located behind the number plate.

Loosen the lock nut and turn the adjuster.  
Tighten the lock nut.

If proper free play cannot be obtained using both procedures or the clutch slips during the test ride, disassemble and inspect the clutch (See section 9).

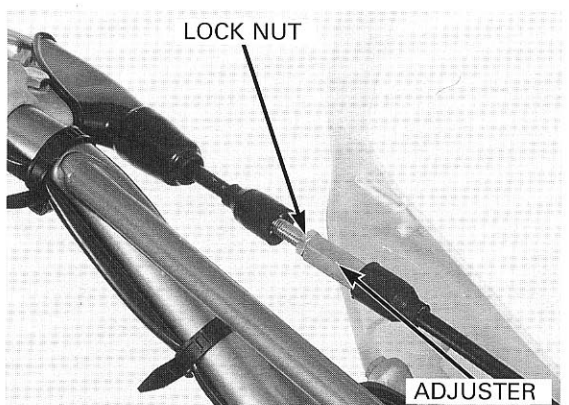

## MAINTENANCE

### CONTROL CABLES

Remove the throttle housing dust cover.  
Remove the throttle cable end cover.  
Remove the throttle cable roller and collar.

Disconnect the throttle cable end from the throttle grip.

Disconnect the clutch cable upper end from the clutch lever.

*It is not necessary to lubricate the cable.*

Thoroughly lubricate the cable pivot points with a commercially available cable lubricant.

If the clutch lever or throttle operation is not smooth, replace the cable.

Be sure the throttle returns freely from fully open to fully closed automatically, in all steering positions.

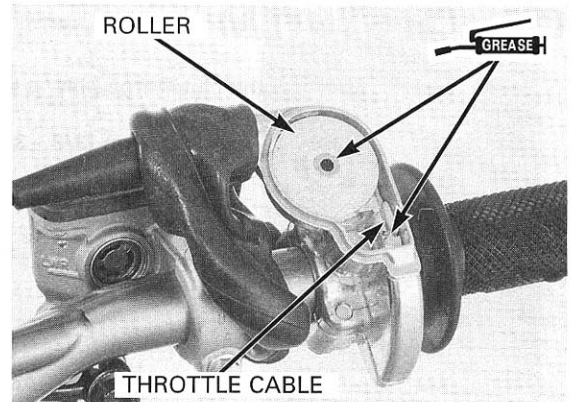
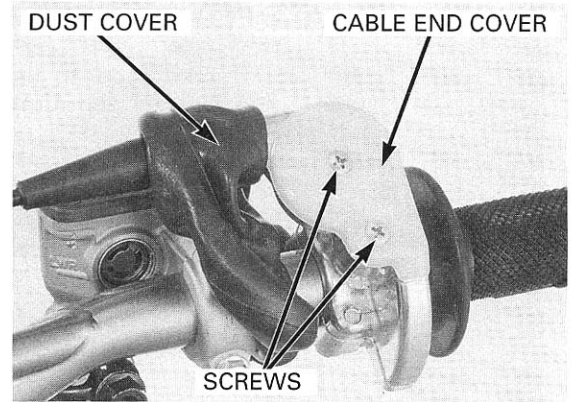

### EXPANSION CHAMBER/SILENCER

#### SILENCER GLASS WOOL REPLACEMENT

Remove the silencer case (page 2-5).

Remove the silencer case bolts.  
Pull out the inner pipe.

*Hold the mounting tab of the silencer case gently in a vise protected with a shop towel.*

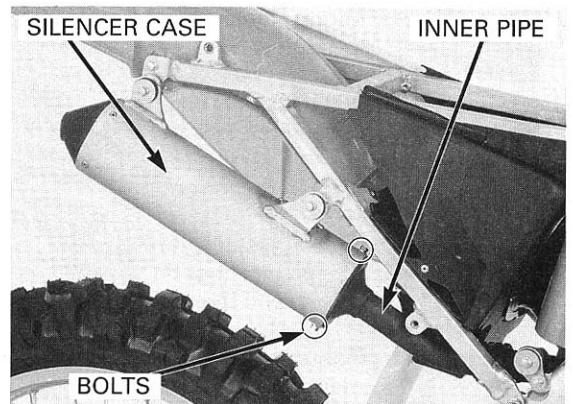

Remove the glass wool packing.

Remove the carbon deposits from the inner pipe using a wire brush.

*Be careful not to damage the glass wool packing.*

Install the new glass wool packing material.

Apply muffler sealant (high-temperature silicone) in the area shown.

Insert the inner pipe and packing into the silencer case and align the bolt hole.

Install and tighten the silencer case bolts.

Wipe off the excess sealant.

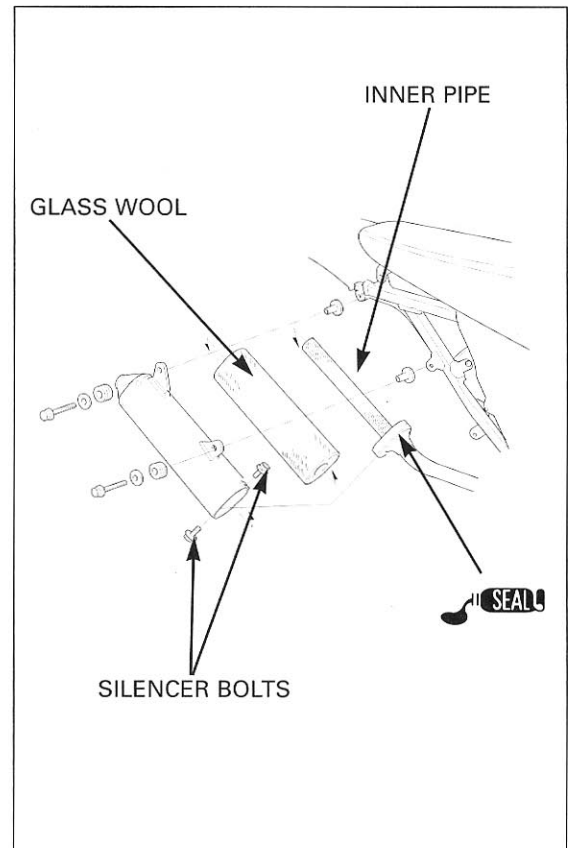

## SUSPENSION

### FRONT SUSPENSION INSPECTION

*Loose, worn or damaged suspension parts impair motorcycle stability and control.*

Check the action of the forks by operating the front brakes and compressing the front suspension several times.

Check the entire assembly for signs of leaks, damage or loose fasteners.

Make sure the fork protectors and dust seals are clean and not packed with mud and dirt.

Remove any dirt that has accumulated on the bottom of the fork seals.

Replace damaged components which cannot be repaired.

Tighten all nuts and bolts.

Refer to section 11 for fork service.

Air pressure acts as a progressive spring and affects the entire range of fork travel.

Air is an unstable gas; it increases in pressure as it is worked (such as in a fork), so the fork action on your CR will get stiffer as the race progresses.

Release built-up air pressure from the fork legs after practice and between heats.

Be sure the fork is fully extended with the front tire off the ground.

Loosen the plug bolts fully, then tighten them.

**TORQUE: 1.2 N·m (0.12 kgf·m, 0.9 lbf·ft)**

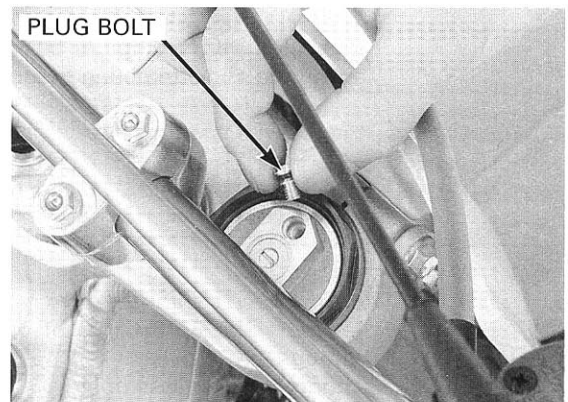

### REAR SUSPENSION INSPECTION

Check the action of the shock absorber by compressing it several times.

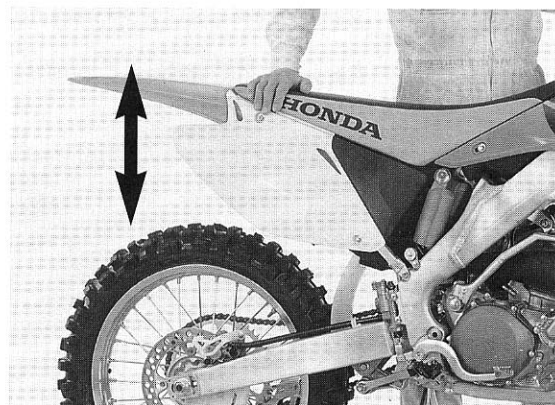

Remove the sub-frame (page 2-3).

Check the entire shock absorber assembly for signs of leaks, damage or loose fasteners. Replace damaged components which cannot be repaired. Tighten all nuts and bolts.

Refer to section 12 for shock absorber service.

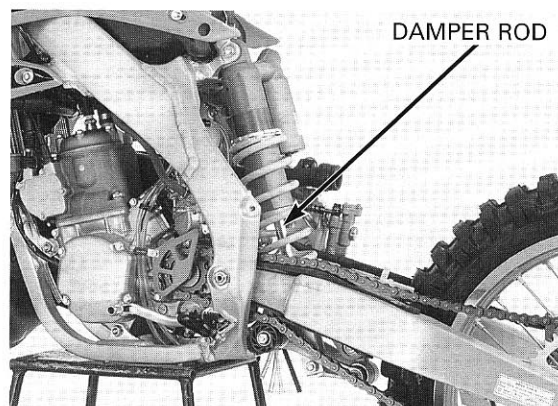

Raise the rear wheel off the ground by placing a workstand under the engine.

Hold the swingarm and move the rear wheel side-ways with force to see if the wheel bearings are worn.



### SWINGARM/SHOCK LINKAGE

Raise the rear wheel off the ground by placing a workstand under the engine.

Check for worn swingarm bearings by grabbing the swingarm and attempting to move it side-to-side.

Replace the bearings if excessively worn (page 12-5).

Check the shock linkage and replace any damaged needle bearings.

Disassemble, clean, inspect the swingarm and shock linkage pivot bearings and related seals every three races or about 7.5 hours of operation (page 12-27 through 12-32).

Lubricate and reassemble.



## NUTS, BOLTS, FASTENERS

Check that all chassis nuts and bolts are tightened to their correct torque values (page 1–10).

Check that all safety clips, hose clamps and cable stays are in place and properly secured.

## WHEELS/TIRES

*Tire pressure should be checked when the tires are cold.*

Check the tires for cuts, embedded nails, or other damage.

Check the front and rear wheels for trueness (refer to section 11 and 12).

Check the cold tire pressure.

### TIRE PRESSURE (FRONT/REAR):

**100 kPa (1.0kgf/cm<sup>2</sup>, 15 psi)**

Inspect the wheel rims and spokes for damage.

Tighten any loose spokes and rim locks to the specified torque.

**TORQUE: SPOKES: 3.7 N·m (0.38 kgf·m, 2.7 lbf·ft)**

**RIM LOCK: 12 N·m (1.2 kgf·m, 9 lbf·ft)**

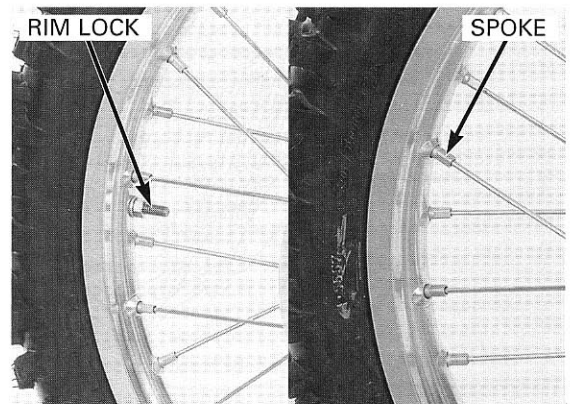
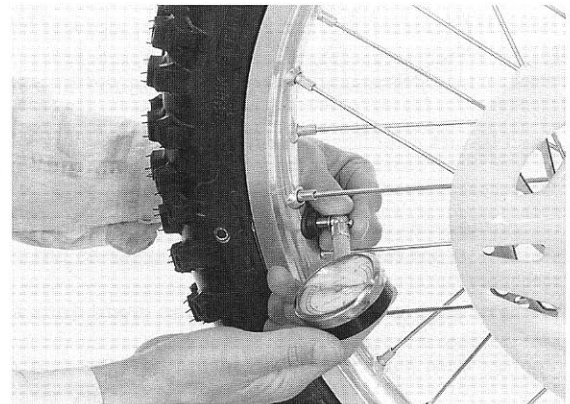

## STEERING HEAD BEARINGS

Raise the front wheel off the ground by placing a workstand under the engine.

*Be sure the control cables do not interfere with handlebar rotation.*

Check that the handlebar moves freely from side to side.

If the handlebar moves unevenly, binds, or has vertical movement, inspect the steering head bearings (section 11).

If excessive play has developed, check the steering stem for cracks.

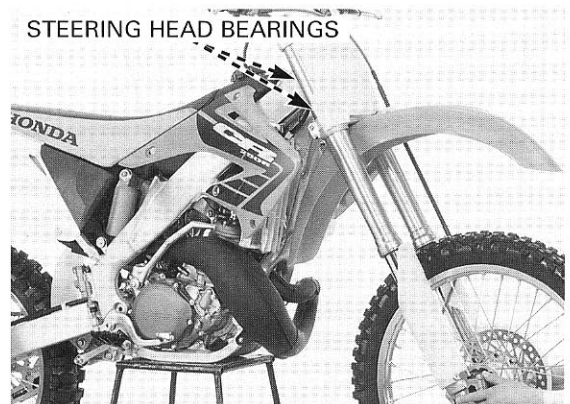

# FUEL SYSTEM

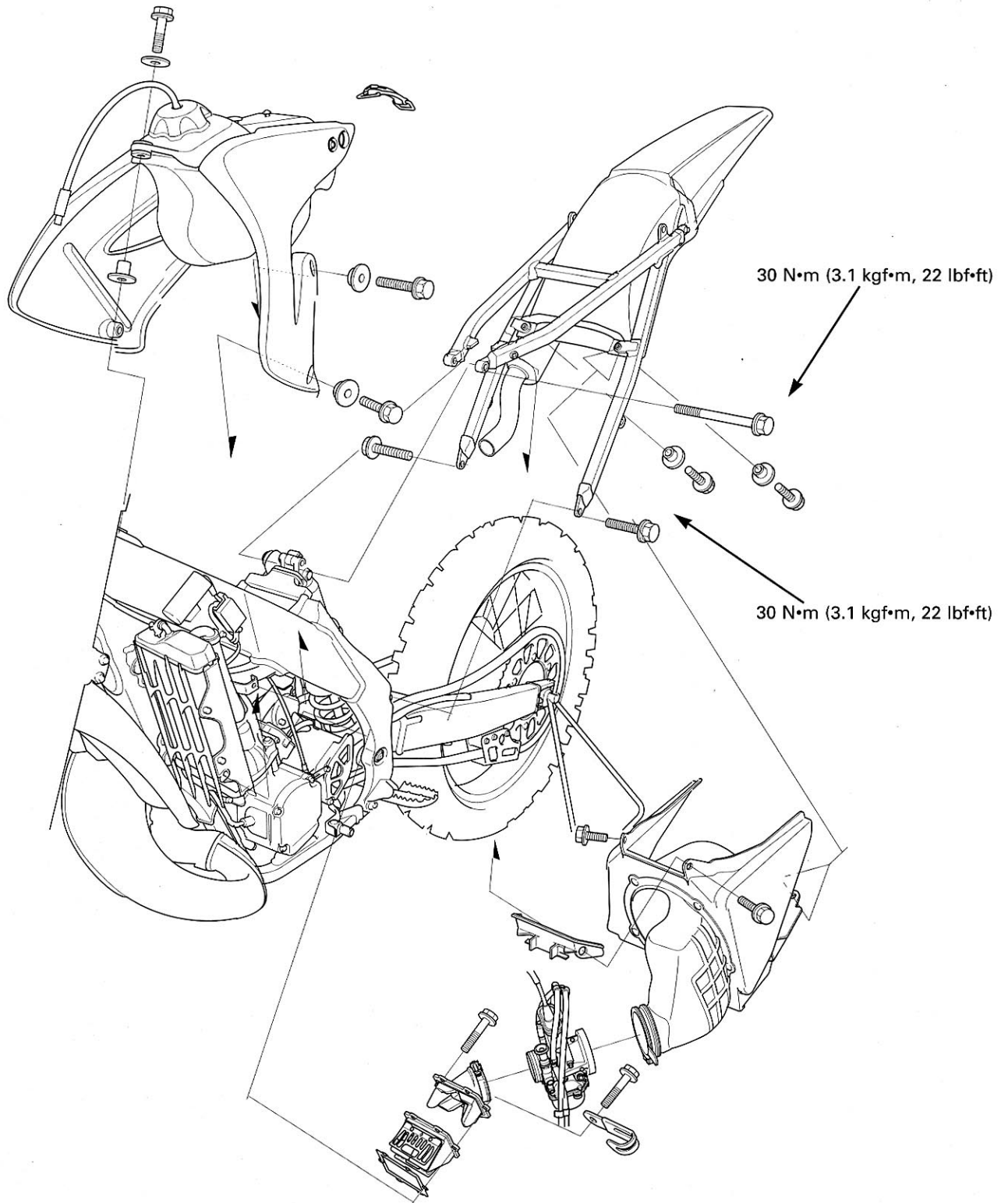

# 4. FUEL SYSTEM

<b>SERVICE INFORMATION</b>	<b>4-1</b>	<b>CARBURETOR ASSEMBLY/ INSTALLATION</b>	<b>4-10</b>
<b>TROUBLESHOOTING</b>	<b>4-2</b>	<b>REED VALVE</b>	<b>4-14</b>
<b>CARBURETOR ADJUSTMENT, MINOR</b>	<b>4-3</b>	<b>AIR CLEANER HOUSING</b>	<b>4-18</b>
<b>CARBURETOR ADJUSTMENT, MAJOR</b>	<b>4-4</b>		
<b>TURNING FOR SPECIAL CONDITIONS</b>	<b>4-6</b>		
<b>CARBURETOR REMOVAL/ DISASSEMBLY</b>	<b>4-7</b>		

## SERVICE INFORMATION

### GENERAL

- Bending or twisting the control cables will impair smooth operation and could cause the cables to stick or bind, resulting in loss of vehicle control.
- Work in a well ventilated area. Smoking or allowing flames or sparks in the work area or where gasoline is stored can cause a fire or explosion.
- Refer to section 2 for fuel tank removal and installation.
- When disassembling fuel system parts, note the location of the O-rings. Replace them with new ones on reassembly.
- Before disassembling the carburetor, place the suitable container under the carburetor drain hose. loosen the bolt and drain the carburetor.
- After removing the carburetor, wrap the intake ports of the engine with a shop towel or cover it with piece of tape to prevent any foreign material from dropping into the engine.
- If the vehicle is to be stored for more than one month, drain the float bowls. Fuel left in the float bowls may cause clogged jets, resulting in hard starting or poor driveability.

### SPECIFICATIONS

ITEM		SPECIFICATIONS
Carburetor identification number	'02	TMX 11B
	After '02	TMX 11C
Main jet	'02	#380
	After '02	#420
Slow jet	'02	#32.5
	After '02	#30
Jet needle	'02	6BEY30-74
	After '02	6BHY38-73
Jet needle clip position (Standard)		2nd
Pilot screw initial opening		1•1/2 turns out
Float level		15.0 mm (0.59 in)
Throttle grip free play		3 – 5 mm (1/8 – 1/4 in)



## FUEL SYSTEM

---

### TORQUE VALUES

Sub-frame mounting bolt (upper)	30 N•m (3.1 kgf•m, 22 lbf•ft)
(lower)	30 N•m (3.1 kgf•m, 22 lbf•ft)
Reed valve stopper screw	1 N•m (0.1 kgf•m, 0.7 lbf•ft)
Throttle cable holder	3 N•m (0.3 kgf•m, 2.2 lbf•ft)
Float pin set screw	2 N•m (0.2 kgf•m, 1.4 lbf•ft)
Needle jet holder	3 N•m (0.3 kgf•m, 2.2 lbf•ft)
Main jet	2 N•m (0.2 kgf•m, 1.4 lbf•ft)
Slow jet	1 N•m (0.1 kgf•m, 0.7 lbf•ft)
Float valve seat set screw	1 N•m (0.1 kgf•m, 0.7 lbf•ft)
Carburetor top screw	2 N•m (0.2 kgf•m, 1.4 lbf•ft)
Throttle stop screw lock nut	2 N•m (0.2 kgf•m, 1.4 lbf•ft)
Float chamber screw	2 N•m (0.2 kgf•m, 1.4 lbf•ft)
Carburetor drain plug	7 N•m (0.7 kgf•m, 5.1 lbf•ft)
Choke valve	4 N•m (0.4 kgf•m, 2.9 lbf•ft)

### TOOLS

Carburetor float level gauge	07401-0010000
------------------------------	---------------

## TROUBLESHOOTING

#### Engine will not start

- Too much fuel getting to the engine
  - Air cleaner clogged
  - Flooded carburetor
- Intake air leak
- Fuel contaminated/deteriorated
- No fuel to carburetor
  - Fuel filter clogged
  - Fuel hose clogged
  - Fuel valve stuck
  - Float level misadjusted
  - Fuel tank breather hose clogged
- Slow circuit clogged
- No spark at plug (faulty spark plug or ignition malfunction)

#### Lean mixture

- Fuel jets clogged
- Fuel tank breather hose clogged
- Fuel filter clogged
- Fuel line restricted
- Float valve faulty
- Float level too low
- Air vent hose clogged
- Advanced ignition timing
- Intake air leak
- Worn crankshaft seal (alternator side)
- Jetting incorrect for altitude/temperature conditions

#### Rich mixture

- Choke valve in "ON" position
- Float valve faulty
- Float level too high
- Air jets clogged
- Air cleaner element contaminated
- Flooded carburetor
- Worn crankshaft seal (clutch side)
- Jetting incorrect for altitude/temperature conditions

#### Engine stalls, hard to start, rough idling

- Fuel line restricted
- Ignition malfunction
- Low cylinder compression
- Fuel mixture too lean/rich
- Fuel contaminated/deteriorated
- Intake air leak
- Float level misadjusted
- Fuel tank breather hose clogged
- Air screw misadjusted
- Slow circuit or starting enrichment circuit clogged

## CARBURETOR ADJUSTMENT, MINOR

### IDLE MIXTURE AND IDLE SPEED

The standard carburetor settings are ideal for the following conditions: 32:1 premix ratio using Honda HP-2 2-stroke oil or its equivalent, sea level altitude, and 20 °C (68 °F) air temperature. If your conditions are different, you may need to adjust the carburetor settings using the tuning information chart (page 4-5).

1. Adjust the carburetor setting using the tuning information chart (page 4-5).

#### STANDARD SETTING ('02):

**FLOAT LEVEL:** 15.0 mm (0.59 in)  
**AIR SCREW INITIAL OPENING:** 1-1/2 turns out  
**SLOW JET:** #32.5  
**MAIN JET:** #380  
**JET NEEDLE:** 6BEY30-74  
**JET NEEDLE CLIP POSITION:** 2nd position

#### STANDARD SETTING (After '02):

**FLOAT LEVEL:** 15.0 mm (0.59 in)  
**AIR SCREW INITIAL OPENING:** 1-1/2 turns out  
**SLOW JET:** #30  
**MAIN JET:** #420  
**JET NEEDLE:** 6BHY38-73  
**JET NEEDLE CLIP POSITION:** 2nd position

2. When the engine is warm enough to run without the choke, push the choke knob down to its "OFF" position.
3. Turn the throttle stop screw to obtain the smoothest idle:
  - To decrease idle speed, turn the screw counterclockwise.
  - To increase idle speed, turn the screw clockwise.
4. Adjust the air screw to obtain the best off-idle performance.
  - If the engine runs rich exiting a corner, turn the air screw counterclockwise to lean the mixture.
  - If the engine runs lean exiting a corner, turn the air screw clockwise to richen the mixture.

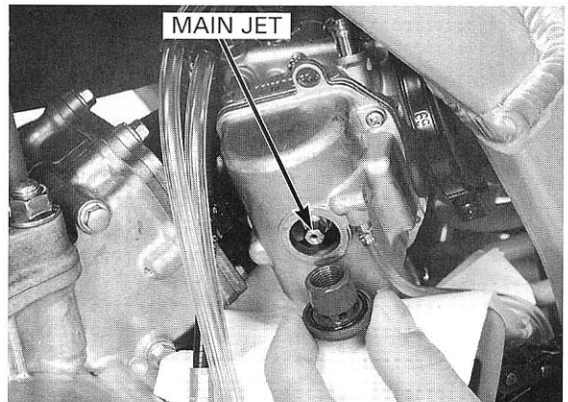
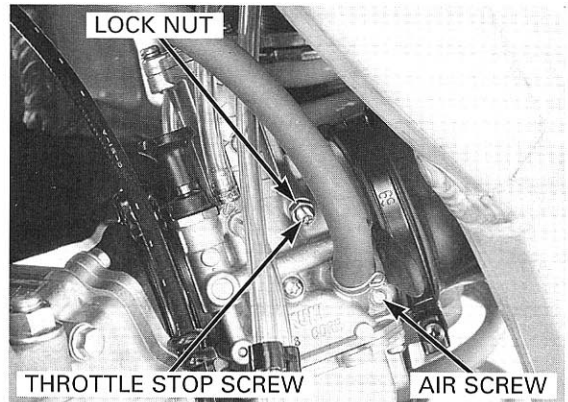
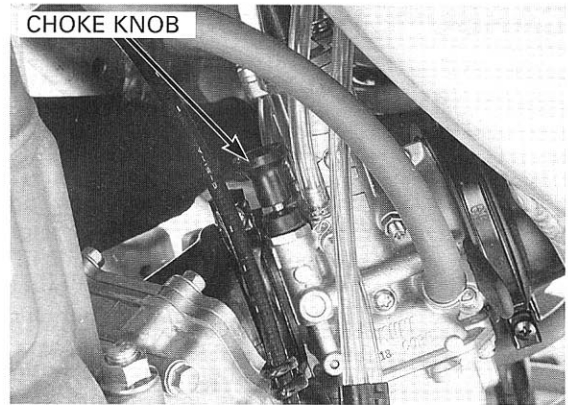

# CARBURETOR ADJUSTMENT, MAJOR FOR TEMPERATURE AND ALTITUDE

1. Warm up the engine.
2. Make two or three laps on a course with the standard setting. Note engine acceleration and other engine conditions in relation to throttle opening. Verify the carburetor by removing the spark plug and reading the firing end.
3. Change the carburetor settings or select suitable carburetor jets, taking into consideration the engine conditions and tuning information chart for temperature and altitude (page 4-5).
4. Turn the fuel valve to "OFF", loosen the carburetor insulator clamp screw and connecting boot clamp screw.
5. Drain the gasoline from the carburetor. Remove the screw, drain plug and float chamber and baffle plate.
6. Change the jets as required and reinstall the float chamber.
7. Remove the jet needle from the throttle valve (page 4-7) and change the jet needle clip position as required.
8. Reinstall the jet needle and carburetor top (page 4-13).
9. Tighten the carburetor insulator clamp screw and connecting boot clamp screw.
10. Adjust the air screw opening as required.

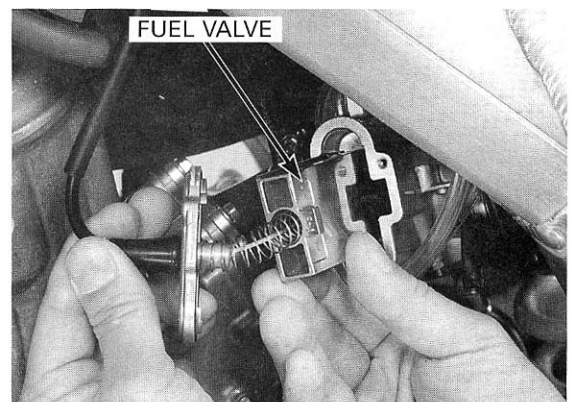
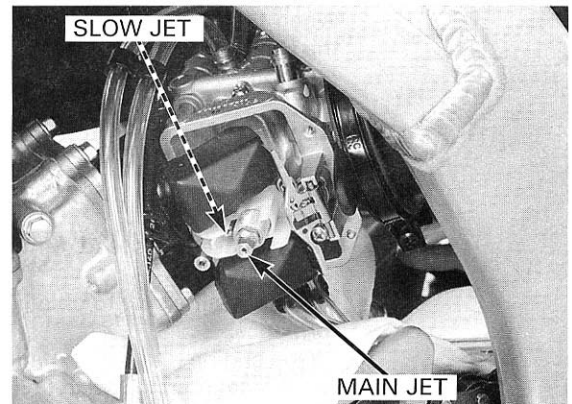
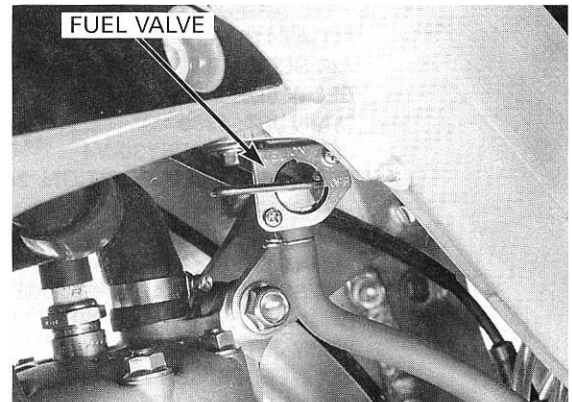
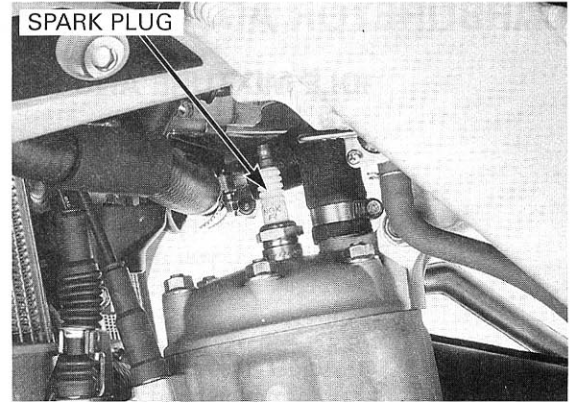

TUNING INFORMATION CHART ('02)

Temperature Altitude	Cent.	-30° ~ -17°	-18° ~ -6°	-7° ~ 5°	4° ~ 16°	15° ~ 27°	26° ~ 38°	37° ~ 49°
	Fahr.	-21° ~ 0°	-1° ~ 20°	19° ~ 40°	39° ~ 60°	59° ~ 80°	79° ~ 100°	99° ~ 120°
3,000 m (10,000 ft)   2,300 m (7,500 ft)	AS: SJ: NC: JN: MJ:	1•1/2 32.5 2nd 6BEY30-74 380	1•3/4 32.5 2nd 6BEY31-74 370	2 32.5 2nd 6BEY31-75 360	2•1/4 32.5 1st 6BEY30-75 350	2•1/2 32.5 1st 6BEY30-75 340	2•1/4 30 1st 6BEY31-76 330	2•1/2 30 1st 6BEY31-76 320
2,299 m (7,499 ft)   1,500 m (5,000 ft)	AS: SJ: NC: JN: MJ:	1•1/4 32.5 2nd 6BEY30-74 390	1•1/2 32.5 2nd 6BEY30-74 380	1•3/4 32.5 2nd 6BEY31-74 370	2 32.5 2nd 6BEY31-75 360	2•1/4 32.5 1st 6BEY30-75 350	2•1/2 32.5 1st 6BEY30-75 340	2•1/4 30 1st 6BEY31-76 330
1,499 m (4,999 ft)   750 m (2,500 ft)	AS: SJ: NC: JN: MJ:	1•1/2 35 3rd 6BEY31-73 400	1•1/4 32.5 2nd 6BEY30-74 390	1•1/2 32.5 2nd 6BEY30-74 380	1•3/4 32.5 2nd 6BEY31-74 370	2 32.5 2nd 6BEY31-75 360	2•1/4 32.5 1st 6BEY30-75 350	2•1/2 32.5 1st 6BEY30-75 340
749 m (2,499 ft)   300 m (1,000 ft)	AS: SJ: NC: JN: MJ:	1•1/4 35 3rd 6BEY30-73 410	1•1/2 35 3rd 6BEY31-73 400	1•1/4 32.5 2nd 6BEY30-74 390	1•1/2 32.5 2nd 6BEY30-74 380	1•3/4 32.5 2nd 6BEY31-74 370	2 32.5 2nd 6BEY31-75 360	2•1/4 32.5 1st 6BEY30-75 350
299 m (999 ft)   Sea level	AS: SJ: NC: JN: MJ:	1 35 3rd 6BEY30-72 420	1•1/4 35 3rd 6BEY30-73 410	1•1/2 35 3rd 6BEY31-73 400	1•1/4 32.5 2nd 6BEY31-73 390	STANDARD 1•1/2 32.5 2nd 6BEY30-74 380	JETTING 1•3/4 32.5 2nd 6BEY31-74 370	2 32.5 2nd 6BEY31-75 360

TUNING INFORMATION CHART (After '02)

Temperature Altitude	Cent.	-30° ~ -17°	-18° ~ -6°	-7° ~ 5°	4° ~ 16°	15° ~ 27°	26° ~ 38°	37° ~ 49°
	Fahr.	-21° ~ 0°	-1° ~ 20°	19° ~ 40°	39° ~ 60°	59° ~ 80°	79° ~ 100°	99° ~ 120°
3,000 m (10,000 ft)   2,300 m (7,500 ft)	AS: SJ: NC: JN: MJ:	1•1/2 30 2nd 6BHY38-73 420	1•3/4 30 2nd 6BHY38-73 410	2 30 2nd 6BHY38-74 400	2•1/4 30 1st 6BHY38-74 390	2•1/2 30 1st 6BHY38-74 380	2•1/4 27.5 1st 6BHY39-75 370	2•1/2 27.5 1st 6BHY39-75 360
2,299 m (7,499 ft)   1,500 m (5,000 ft)	AS: SJ: NC: JN: MJ:	1•1/2 32.5 2nd 6BHY38-73 430	1•1/2 30 2nd 6BHY38-73 420	1•3/4 30 2nd 6BHY38-73 410	2 30 2nd 6BHY38-74 400	2•1/4 30 1st 6BHY38-74 390	2•1/2 30 1st 6BHY38-74 380	2•1/4 27.5 1st 6BHY39-75 370
1,499 m (4,999 ft)   750 m (2,500 ft)	AS: SJ: NC: JN: MJ:	1•1/2 35 3rd 6BHY39-72 440	1•1/2 32.5 2nd 6BHY38-73 430	1•1/2 30 2nd 6BHY38-73 420	1•3/4 30 2nd 6BHY38-73 410	2 30 2nd 6BHY38-74 400	2•1/4 30 1st 6BHY38-74 390	2•1/2 30 1st 6BHY38-74 380
749 m (2,499 ft)   300 m (1,000 ft)	AS: SJ: NC: JN: MJ:	1•1/4 35 3rd 6BHY38-72 450	1•1/2 35 3rd 6BHY39-72 440	1•1/2 32.5 2nd 6BHY38-73 430	1•1/2 30 2nd 6BHY38-73 420	1•3/4 30 2nd 6BHY38-73 410	2 30 2nd 6BHY38-74 400	2•1/4 30 1st 6BHY38-74 390
299 m (999 ft)   Sea level	AS: SJ: NC: JN: MJ:	1 35 3rd 6BHY38-71 460	1•1/4 35 3rd 6BHY38-72 450	1•1/2 35 3rd 6BHY39-72 440	1•1/2 32.5 2nd 6BHY38-73 430	STANDARD 1•1/2 30 2nd 6BHY38-73 420	JETTING 1•3/4 30 2nd 6BHY38-73 410	2 30 2nd 6BHY38-74 400

Legend.

- AS: Air Screw opening from fully seated
- SJ: Slow Jet
- NC: Needle Clip position
- MJ: Main Jet
- JN: Jet Needle

## FUEL SYSTEM

---

- If you use the chart correctly, it should not be necessary adjust more than one jet size richer or leaner to fine tune your CR. If a very large adjustment is required, there may be something wrong elsewhere. Check for worn crankshaft seals, air leaks, blocked exhaust or fuel system, or dirty air cleaner element.
- The tuning information chart will get you very close to the ideal setting. However, because of differences in pressure and humidity, you may need to fine tune the carburetor for race day condition.
- Just off idle:
  - Engine stumbles/hesitates (rich): turn out the air screw 1/4 turn.
  - Engine surges (lean): turn in the air screw 1/4 turn.
- The minimum to maximum range of air screw adjustment is 1 to 3 turns out from the lightly seated position.
  - If you exceed 3 turns out, the next smaller slow jet is needed.
  - If you are under 1 turn out, the next larger slow jet is needed.
- On the top end:
  - Engine stumbles/hesitates (rich): go to next smaller main jet.
  - Engine surges (lean): go to next larger main jet.
- To prevent engine damage, always adjust the main jet (top end) before adjusting the jet needle (mid-range).
- In the mid-range:
  - Engine stumbles/hesitates (rich): lower the jet needle by raising the needle clip one position.
  - Engine surges (lean): raise the jet needle by lowering the needle clip one position.

## TUNING FOR SPECIAL CONDITIONS

Once you have adjusted the carburetor for temperature and altitude, it should not need major readjustment unless the race conditions change drastically. Exclusive of the tuning information chart, there are some unique atmospheric conditions that may require additional adjustments. See below:

### Main jet:

- Go richer on the main jet, by one number, when the track has a very long straightaway, steep climbs, a high percentage of sand, or the track is muddy.
- Go leaner on the main jet, by one number, when it is very humid or raining, or if it is hotter than 45 °C (113 °F).

### Jet needles:

- Under normal circumstances, the standard jet needle can be adjusted to fit most situations. However, a peculiar condition may require replacement of the standard jet needle. But before replacing the standard needle, complete all the carburetor adjustments (page 4–3 through 6). If mid-range performance is still not satisfactory, try one of the optional jet needles. See page 1–20.

## CARBURETOR REMOVAL/ DISASSEMBLY

### REMOVAL

Disconnect the fuel hose.  
Turn the handlebar to the left fully.  
Loosen the carburetor insulator band screw and connecting boot band screw, and lean the carburetor to the left.

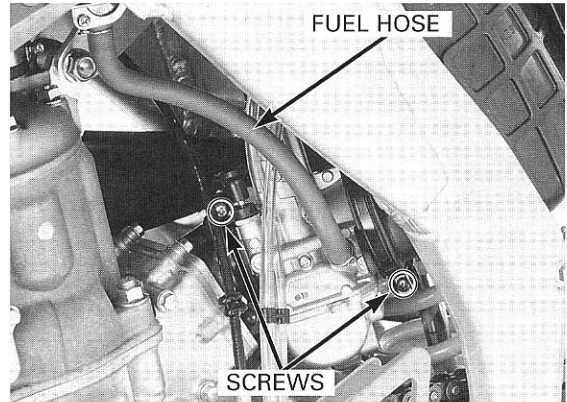

Remove the screws and carburetor top, then pull out the throttle valve.

Remove the carburetor.

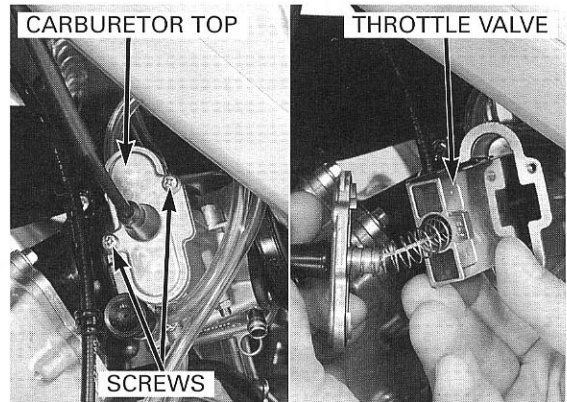

### DISASSEMBLY

Compress the spring and remove the collar from the throttle valve.

Compress the spring and remove the throttle cable from the carburetor holder.

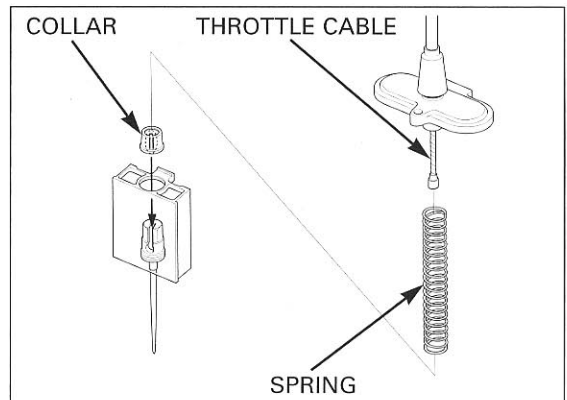

Remove the throttle cable holder and jet needle from the throttle valve.

Check the jet needle for stepped wear or damage.  
Check the throttle valve for damage.

Replace these parts if necessary.

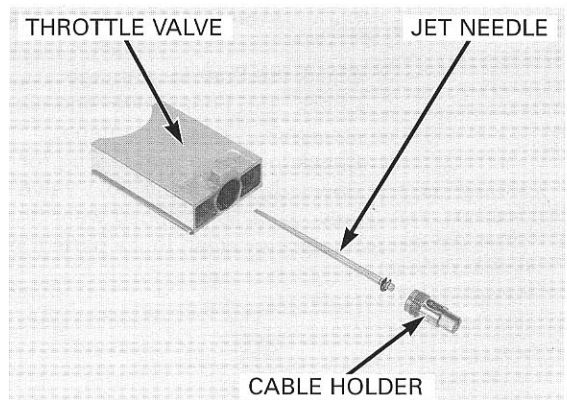

## FUEL SYSTEM

Disconnect the air vent hoses and overflow hose.

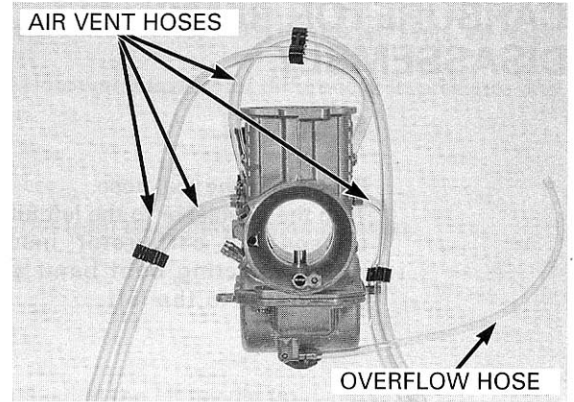

Remove the carburetor drain plug and screw.  
Remove the float chamber and O-ring.

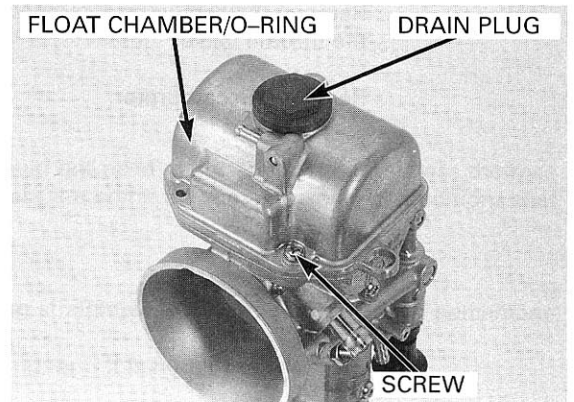

Remove the float pin set screw and float pin.  
Remove the float and float valve.

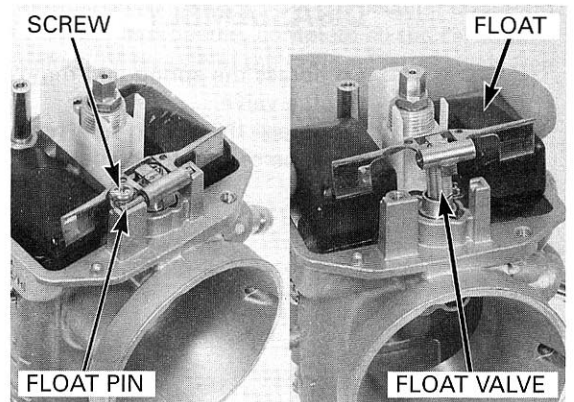

Remove the valve seat set screw and valve seat.

Check the float for damage.  
Check the float valve and valve seat for scoring, scratches, clogs or damage.  
Check the valve seat O-ring for wear or damage.  
Check the tip of the float valve where it contacts the valve seat, for stepped wear or contamination.  
Replace or clean these parts if necessary.

*A worn or contaminated valve does not seat properly and will eventually flood the carburetor.*

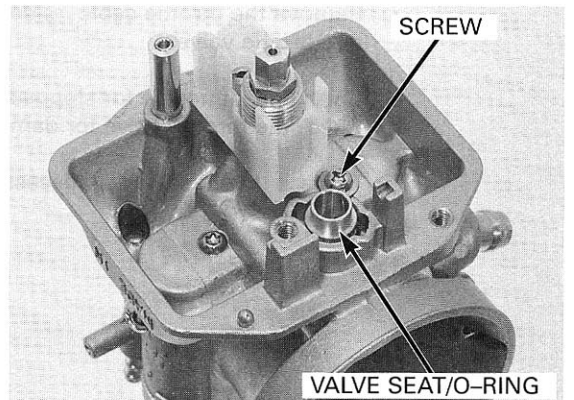

Remove the baffle plate, main jet, needle jet holder and slow jet.

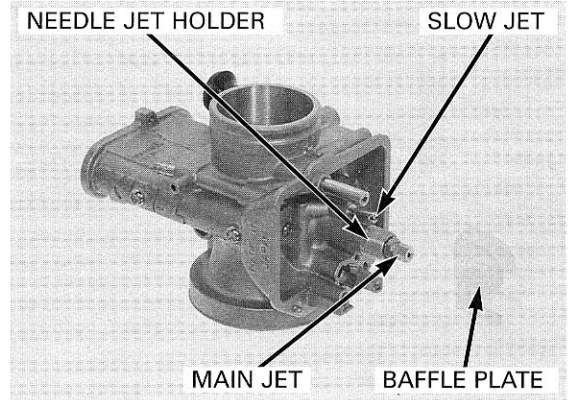

*Before removing the air screw, record the number of turns in until it seats lightly, so it can be returned to its original position.*

Remove the air screw and throttle stop screw.

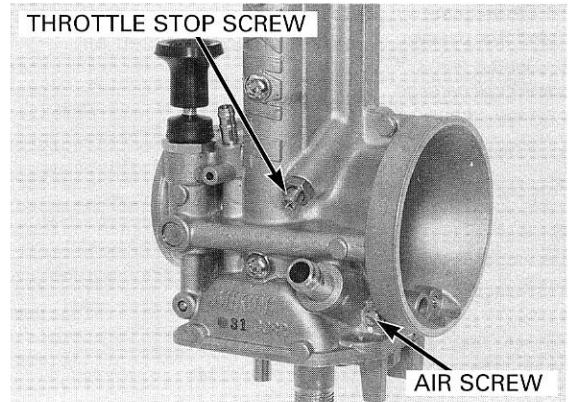

Check each jet for wear or damage.  
Clean the jets with non-flammable or high flash-point solvent and blow open with compressed air.

Check the air screw for stepped wear or damage.  
Check the spring for damage.  
Replace these parts if necessary.

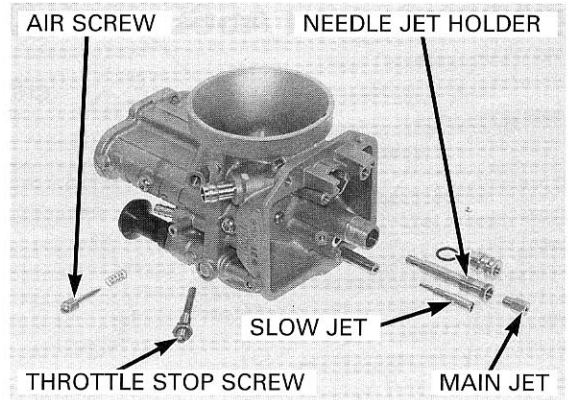

Unscrew the lock nut and remove the choke knob.

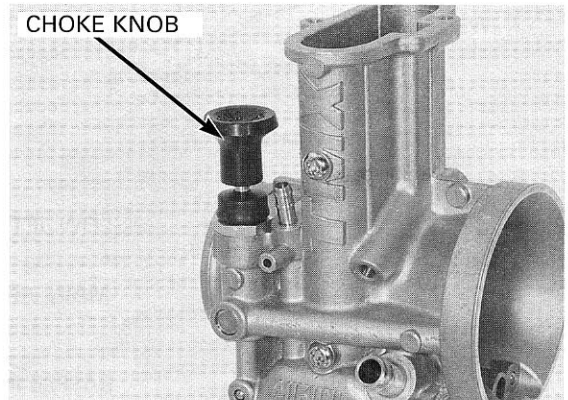



# FUEL SYSTEM

Check the valve seat for damage or stepped wear.



*Cleaning the air and fuel passage with a piece of wire will damage the carburetor body.*

Blow open all air and fuel passages in the carburetor body with compressed air.

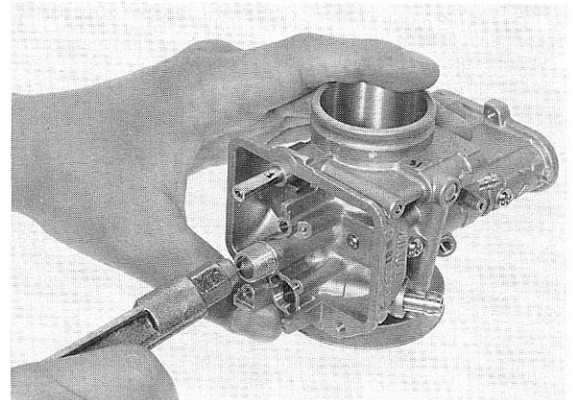

## CARBURETOR ASSEMBLY/INSTALLATION

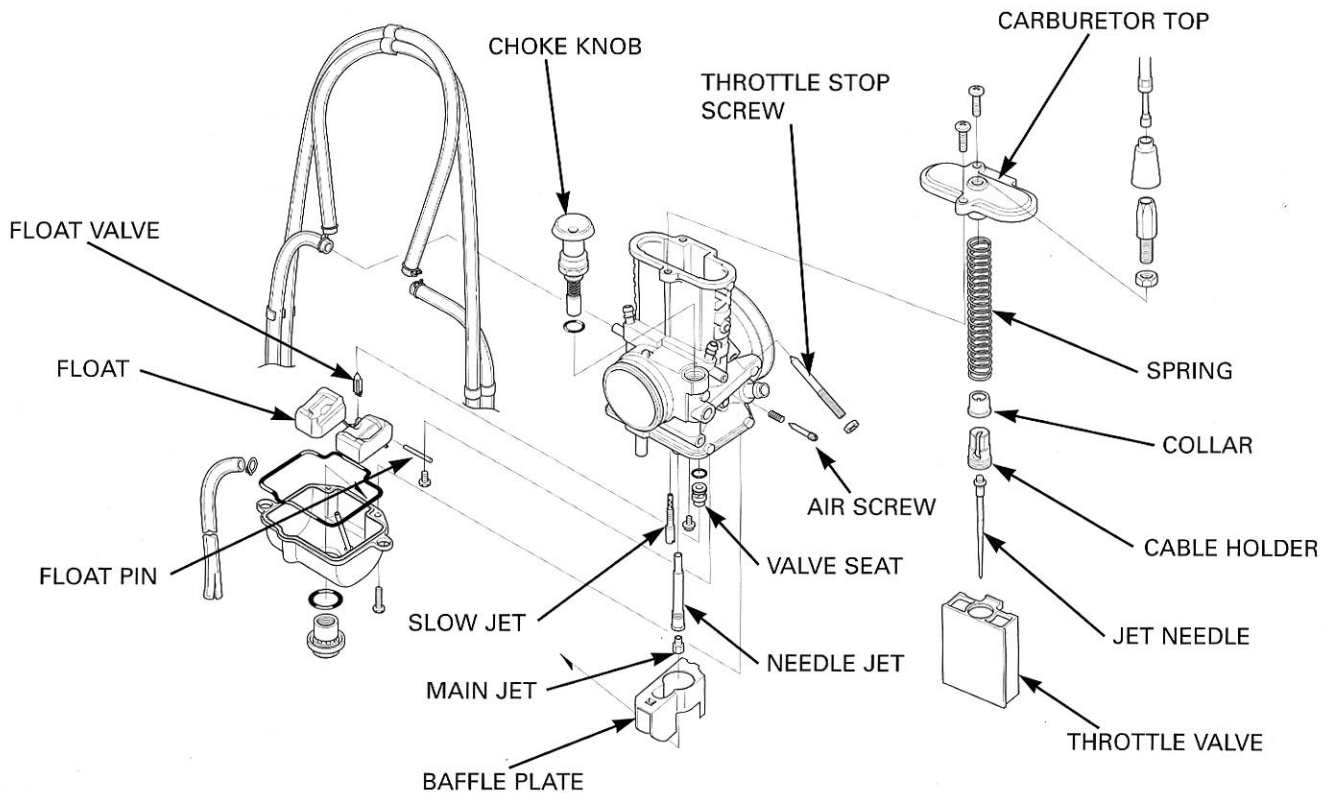

**ASSEMBLY**

Install the choke knob and tighten the lock nut to the specified torque.

**TORQUE: 4 N·m (0.4 kgf·m, 2.9 lbf·ft)**

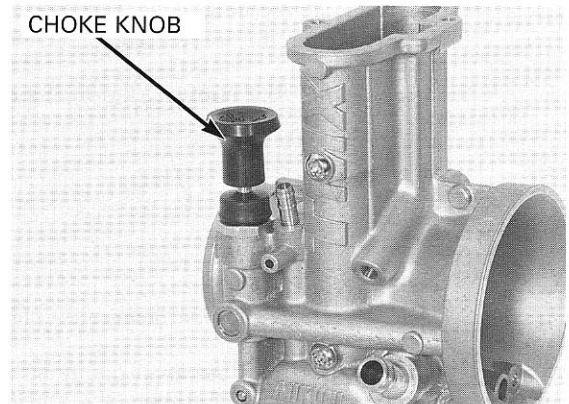

CHOKE KNOB

*Install the air screw and return it to its original position as noted during removal.*

Install the air screw and throttle stop screw.

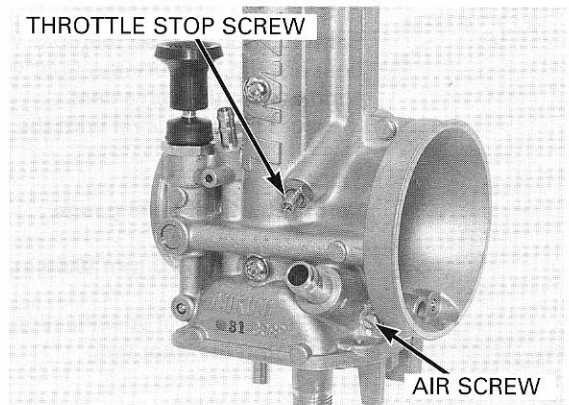

THROTTLE STOP SCREW

AIR SCREW

Install the slow jet, needle jet holder, main jet and baffle plate.

**TORQUE:**

- SLOW JET:** 1 N·m (0.1 kgf·m, 0.7 lbf·ft)
- NEEDLE JET HOLDER:** 3 N·m (0.3 kgf·m, 2.2 lbf·ft)
- MAIN JET** 2 N·m (0.2 kgf·m, 1.4 lbf·ft)

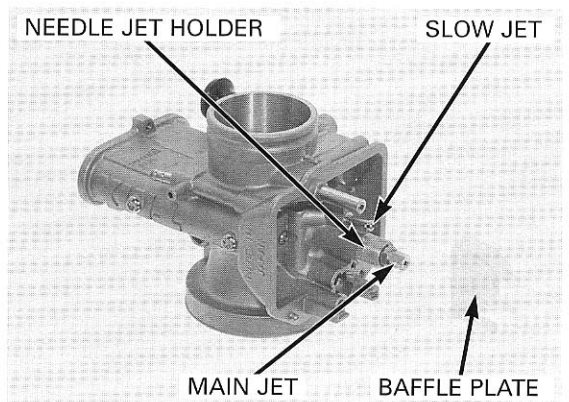

NEEDLE JET HOLDER

SLOW JET

MAIN JET

BAFFLE PLATE

Install the float valve seat and O-ring. Tighten the screw to the specified torque.

**TORQUE: 1 N·m (0.1 kgf·m, 0.7 lbf·ft)**

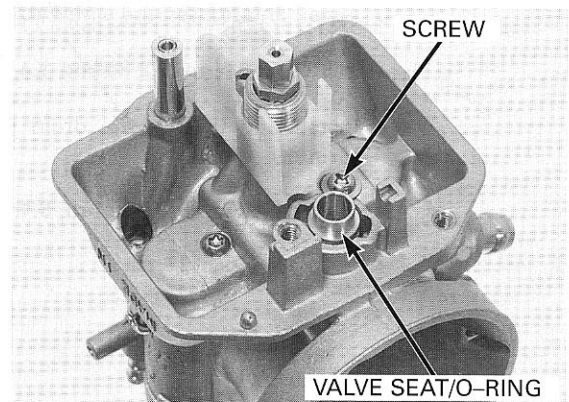

SCREW

VALVE SEAT/O-RING

## FUEL SYSTEM

Install the float valve, float and float pin.  
Tighten the screw to the specified torque.

**TORQUE: 2 N•m (0.2 kgf•m, 1.4 lbf•ft)**

- Check the float level after checking the float valve and float.
- Set the float level gauge so it is perpendicular to the float chamber face and in-line with the main jet.

Set the carburetor so the float valve just contacts the float arm lip. Be sure the float valve tip is securely in contact with the valve seat.  
Measure the float level with the float level gauge.

**TOOL:**

**Carburetor float level gauge 07401-0010000**

**FLOAT LEVEL: 15.0 mm (0.59 in)**

If the level is out of specification, adjust the float level by bending the float tang.

Install a new O-ring to the float chamber.  
Install the float chamber to the carburetor.

Install and tighten the screw to the specified torque.

**TORQUE: 2 N•m (0.2 kgf•m, 1.4 lbf•ft)**

Install and tighten the drain plug to the specified torque.

**TORQUE: 7 N•m (0.7 kgf•m, 5.1 lbf•ft)**

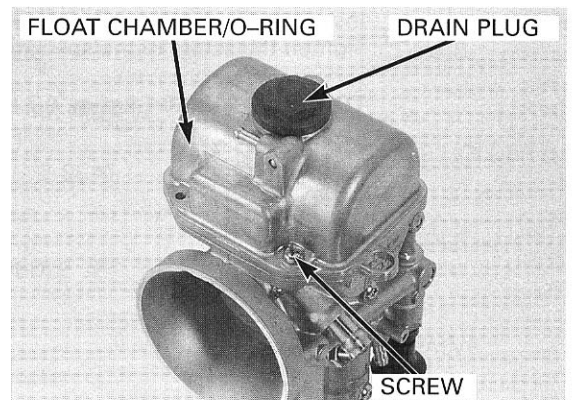
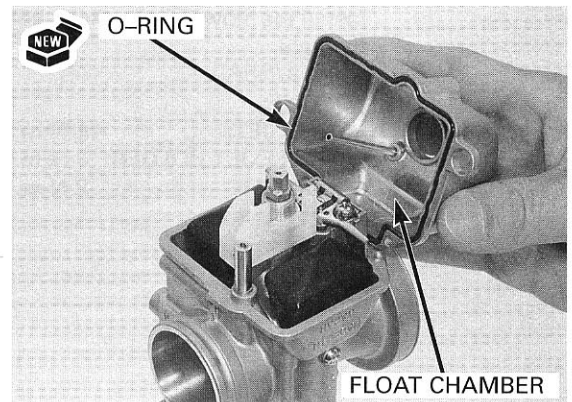
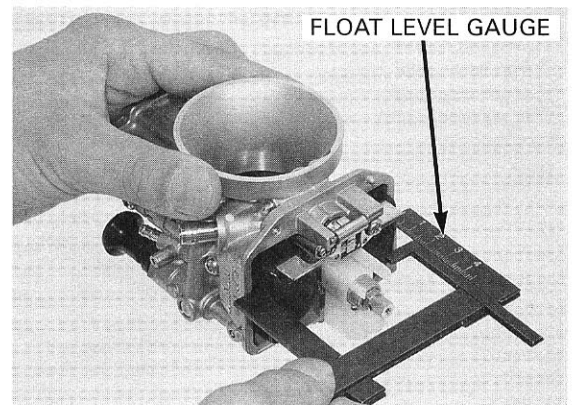
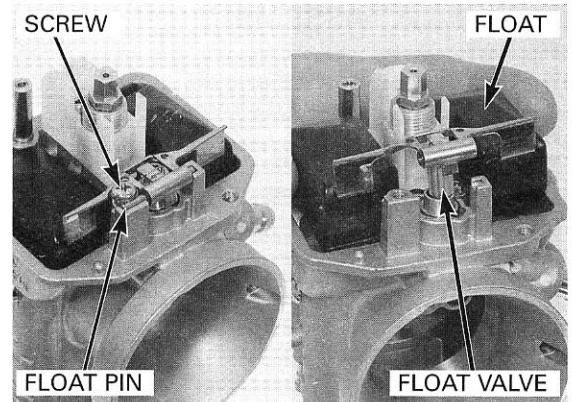

Connect the air vent hoses and overflow hose.

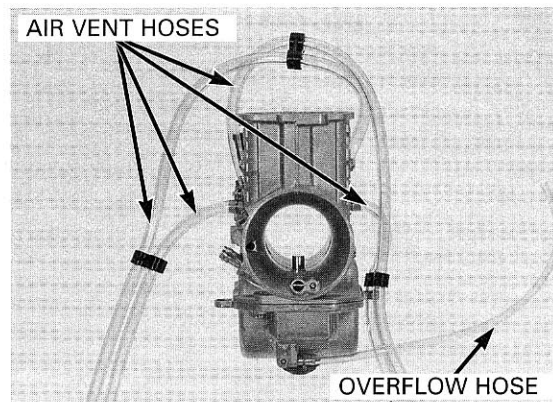

Install the jet needle clip to the jet needle.

**STANDARD CLIP POSITION: 2nd groove**

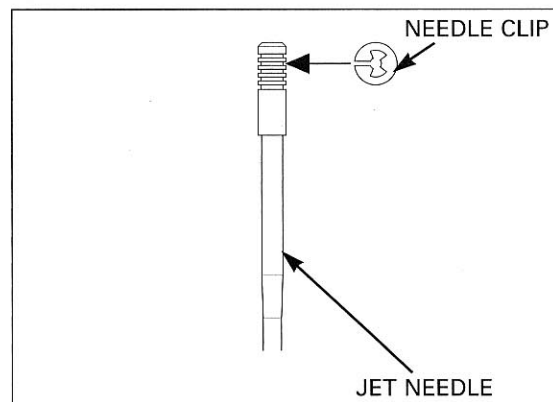

Install the jet needle into the throttle valve.  
Install the cable holder into the throttle valve then tighten the cable holder to the specified torque.

**TORQUE: 3 N·m (0.3 kgf·m, 2.2 lbf·ft)**

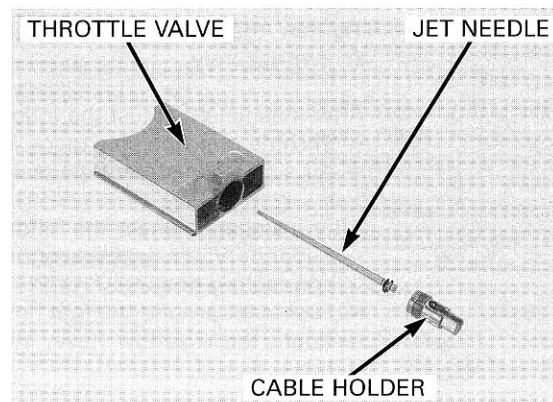

Guide the throttle cable through the throttle valve spring and collar.

Compress the throttle valve spring and insert the throttle cable into the cable holder.

Install the collar by aligning the tab of the collar with the cut-out in the cable holder.

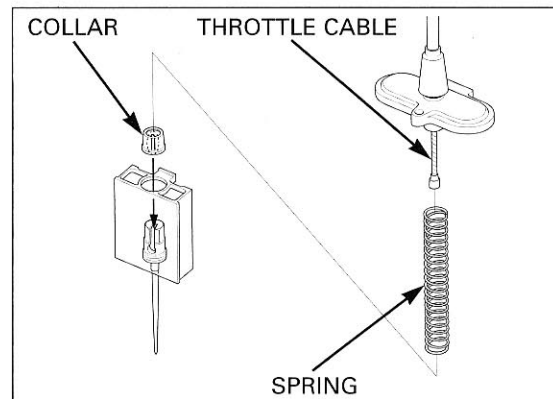

## FUEL SYSTEM

### INSTALLATION

Loosely install the carburetor.  
Move the carburetor to the left and slide the throttle valve assembly into the carburetor with the cut-out and tab side facing the air cleaner.

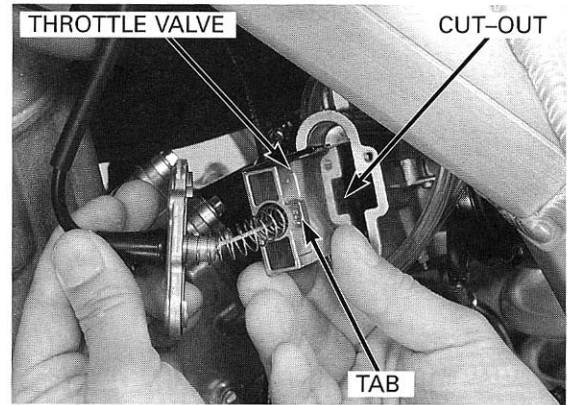

Install the carburetor top cover and tighten the screws to the specified torque.

**TORQUE: 2 N·m (0.2 kgf·m, 1.4 lbf·ft)**

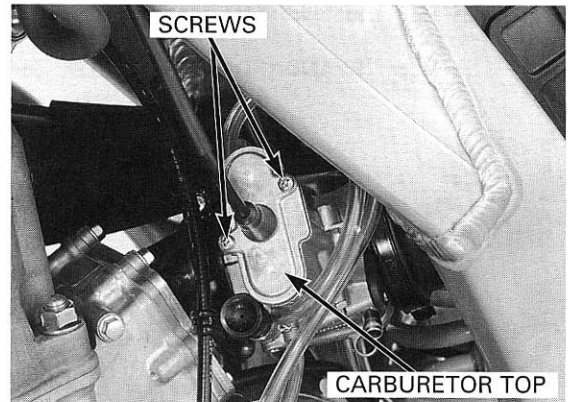

Align the lug on the carburetor with the groove in the carburetor insulator.  
Tighten the insulator and connecting boot band screws securely.

After installation adjust the following:

- Throttle grip free play (page 3-5)
- Air screw adjustment (page 4-3)

After installation check the following:

- Secondary air leaks around the insulator and connecting hose
- Fuel leaks around the fuel hose and carburetor
- Route the overflow hose, air vent hose and fuel hose

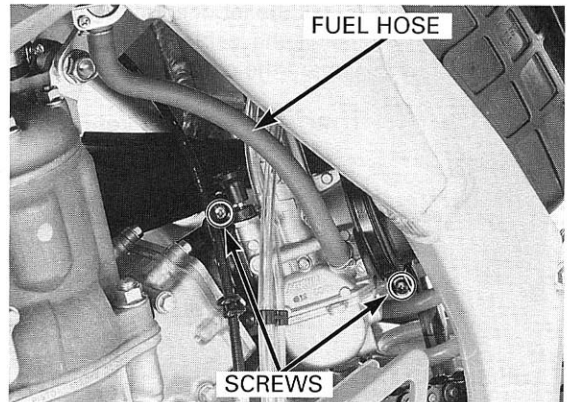

## REED VALVE

### REMOVAL

Remove the carburetor (page 4-7).

Remove the bolts, clutch cable clamp and insulator.

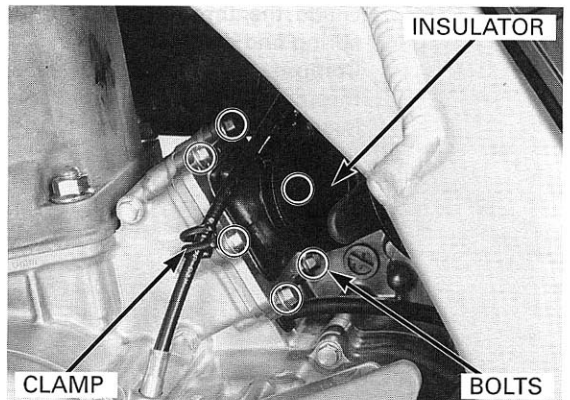

Remove the reed valve and gasket.

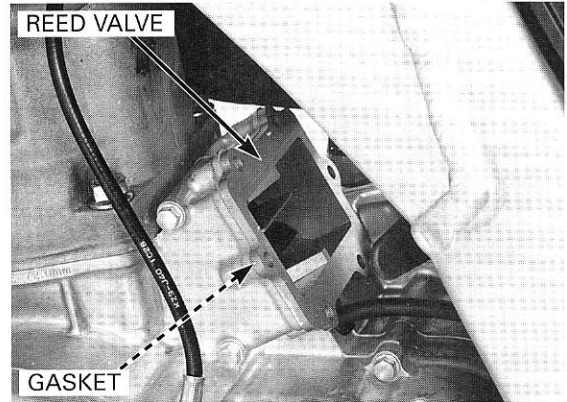

Check the reed valve for fatigue or damage and replace the reed valve if necessary.

Check the reed valve stopper for cracks, damage and clearance from the reed, and replace the reed valve stopper if necessary.

**DISASSEMBLY/ASSEMBLY ('02)**

Remove the following:

- Screws
- Reed valve stoppers
- Spacers
- Upper sub reed valve
- Lower sub reed valve
- Upper reed valve
- Lower reed valve

Replace the reed valve after three races or about 7.5 hours.

During installation, do not mix the upper sub reed valve, upper reed valve and lower sub reed valve, lower reed valve. Make sure they are installed in their original location.

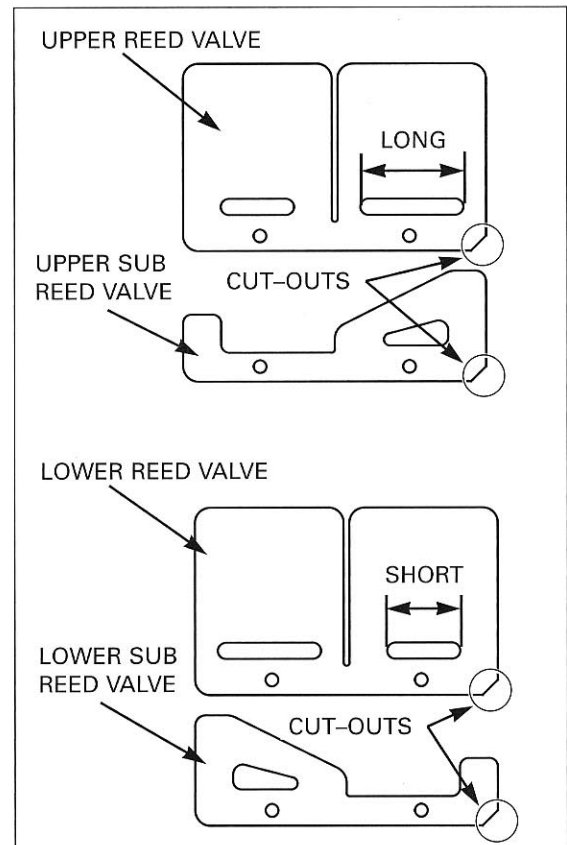
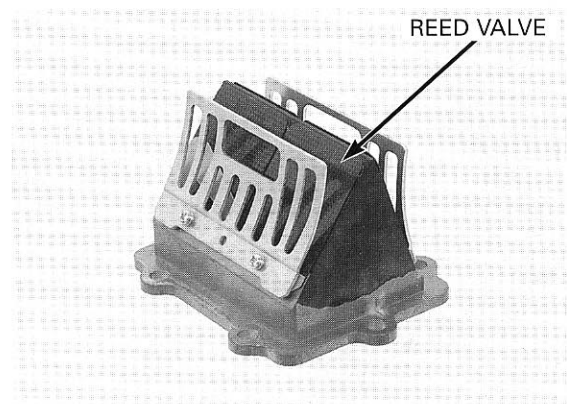

## FUEL SYSTEM

Install the reed valve and reed valve stopper aligning the cut-out in the reed valve and the cut-out in the reed valve stopper.

*Do not apply locking agent to the reed valve.*

Clean the screw threads.

Apply a small amount of locking agent to the tip of the screw threads.

Tighten the screws to the specified torque.

**TORQUE: 1 N•m (0.1 kgf•m, 0.7 lbf•ft)**

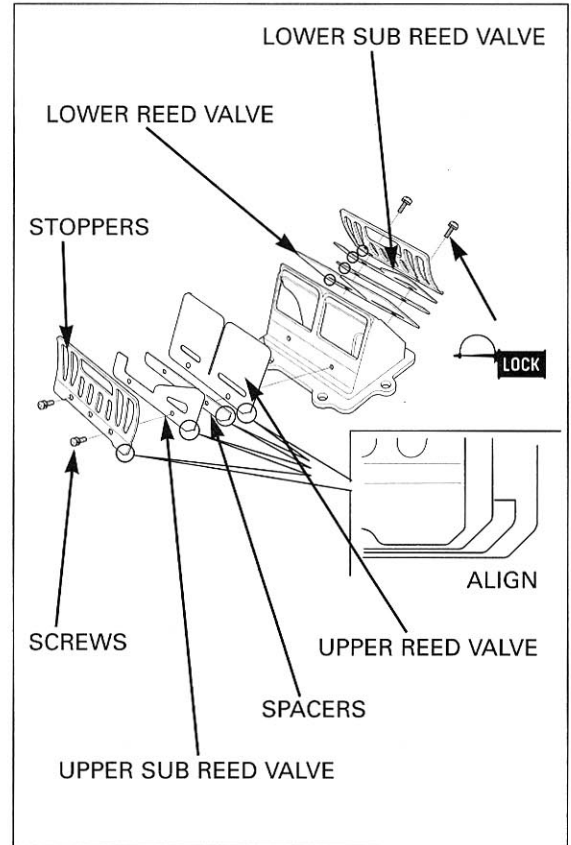

After installation, check for reed valve clearance.

**CLEARANCE: 0.2 mm (0.01 in)**

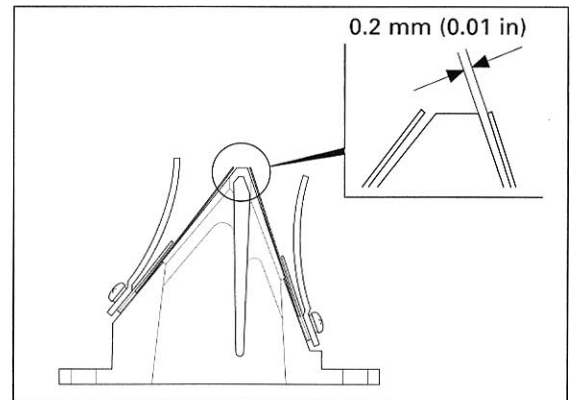

### DISASSEMBLY/ASSEMBLY (After '02)

Remove the following:

- Screws
- Reed valve stoppers
- Reed valves

Replace the reed valve after three races or about 7.5 hours.

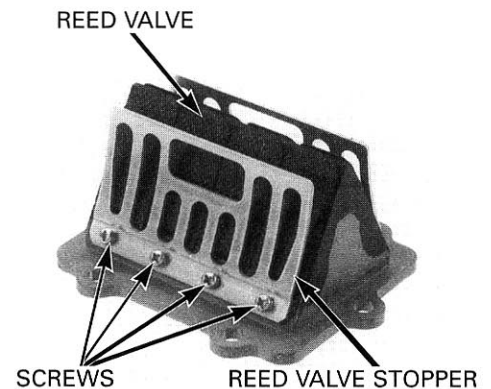

Install the reed valve and reed valve stopper aligning the cut-out in the reed valve and the cut-out in the reed valve stopper.

Clean the screw threads.  
Apply a small amount of locking agent to the tip of the screw threads.  
Tighten the screws to the specified torque.

**TORQUE: 1 N·m (0.1 kgf·m, 0.7 lbf·ft)**

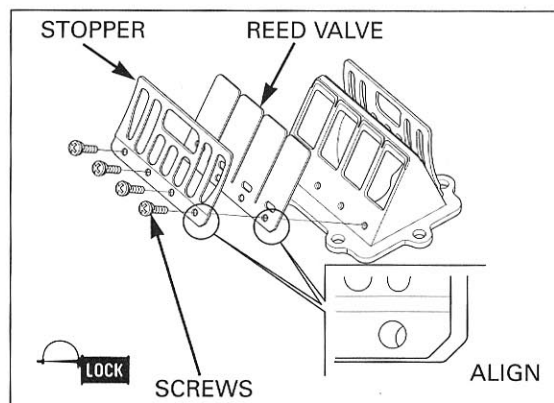

After installation, check for reed valve clearance.

**CLEARANCE: 0.2 mm (0.01 in)**

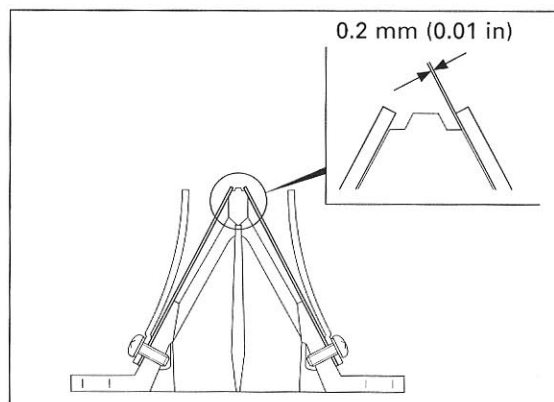

### INSTALLATION ('02)

Install the new gasket to the crankcase.  
Install the reed valve to the crankcase with its up side facing up.

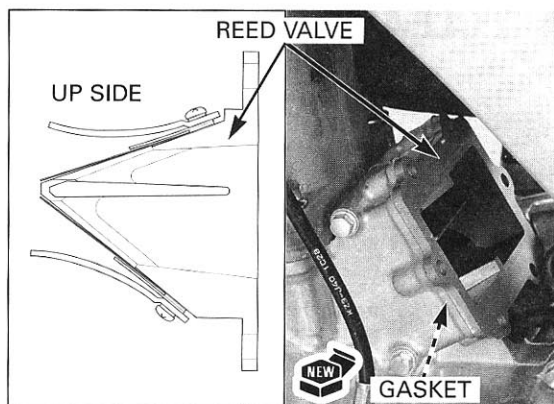

Install the insulator, clutch cable holder and bolts.  
Tighten the bolts securely.

Install the carburetor (page 4-14).

After installation check the following:  
— Secondary air leaks around the insulator and connecting boot  
— Fuel leaks around the fuel hose and carburetor

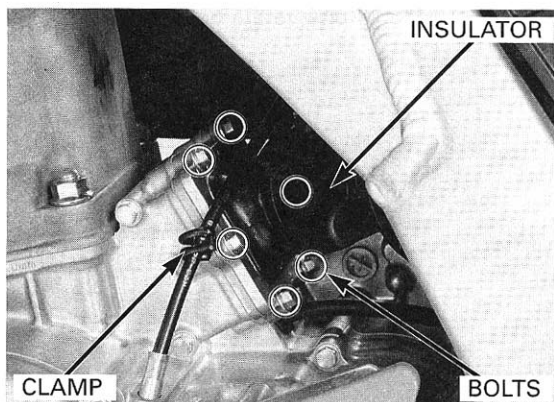



## FUEL SYSTEM

### INSTALLATION (After '02)

Install the new gasket to the crankcase.  
Install the reed valve to the crankcase as shown.

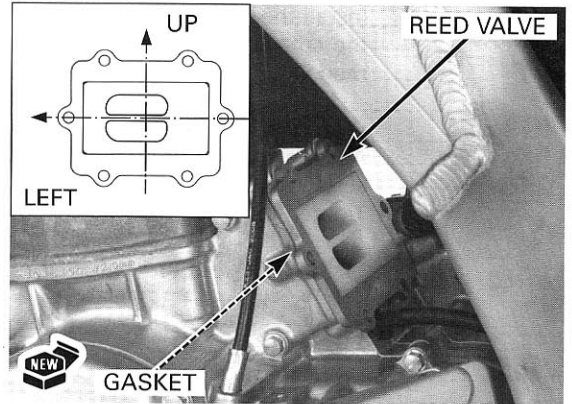

Install the insulator, clutch cable holder and bolts.  
Tighten the bolts securely.

Install the carburetor (page 4-14).

After installation check the following:

- Secondary air leaks around the insulator and connecting boot
- Fuel leaks around the fuel hose and carburetor

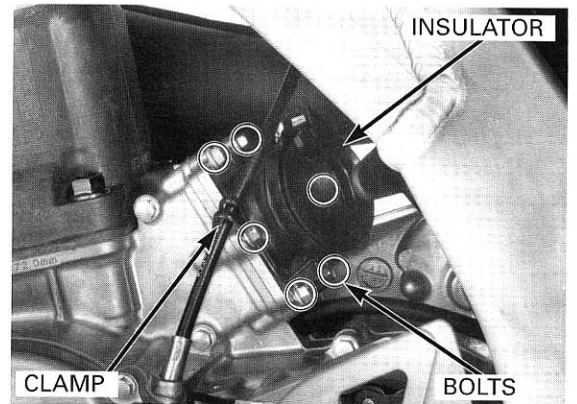

## AIR CLEANER HOUSING

### REMOVAL

Remove the sub-frame (page 2-3).

Remove the screws and mud guard.

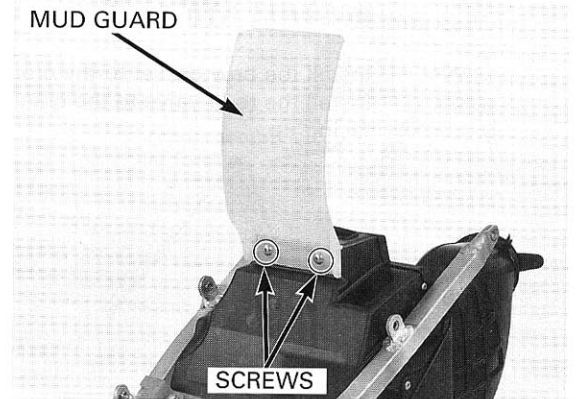

Remove the bolts.

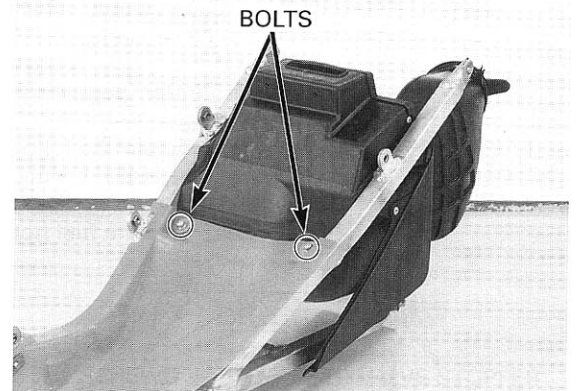

Remove the bolts and air cleaner housing from the sub-frame.

Remove the air cleaner element (page 3-5).  
Check the carburetor connecting hose to see if it is sealing properly at the air cleaner housing.  
Check the air cleaner housing for damage.

Remove the carburetor connecting hose from the air cleaner housing and seal thoroughly if any sign of inadequate sealing is detected.

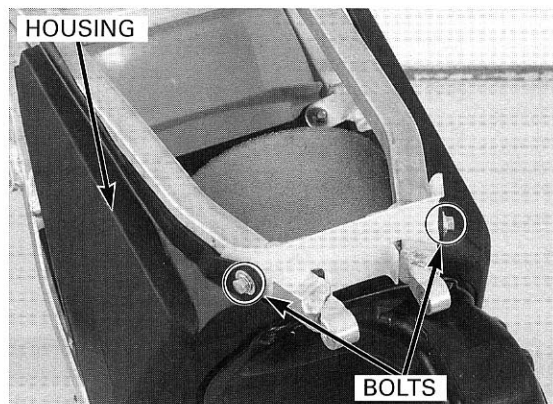

### INSTALLATION

Air cleaner housing installation is in the reverse order of removal.

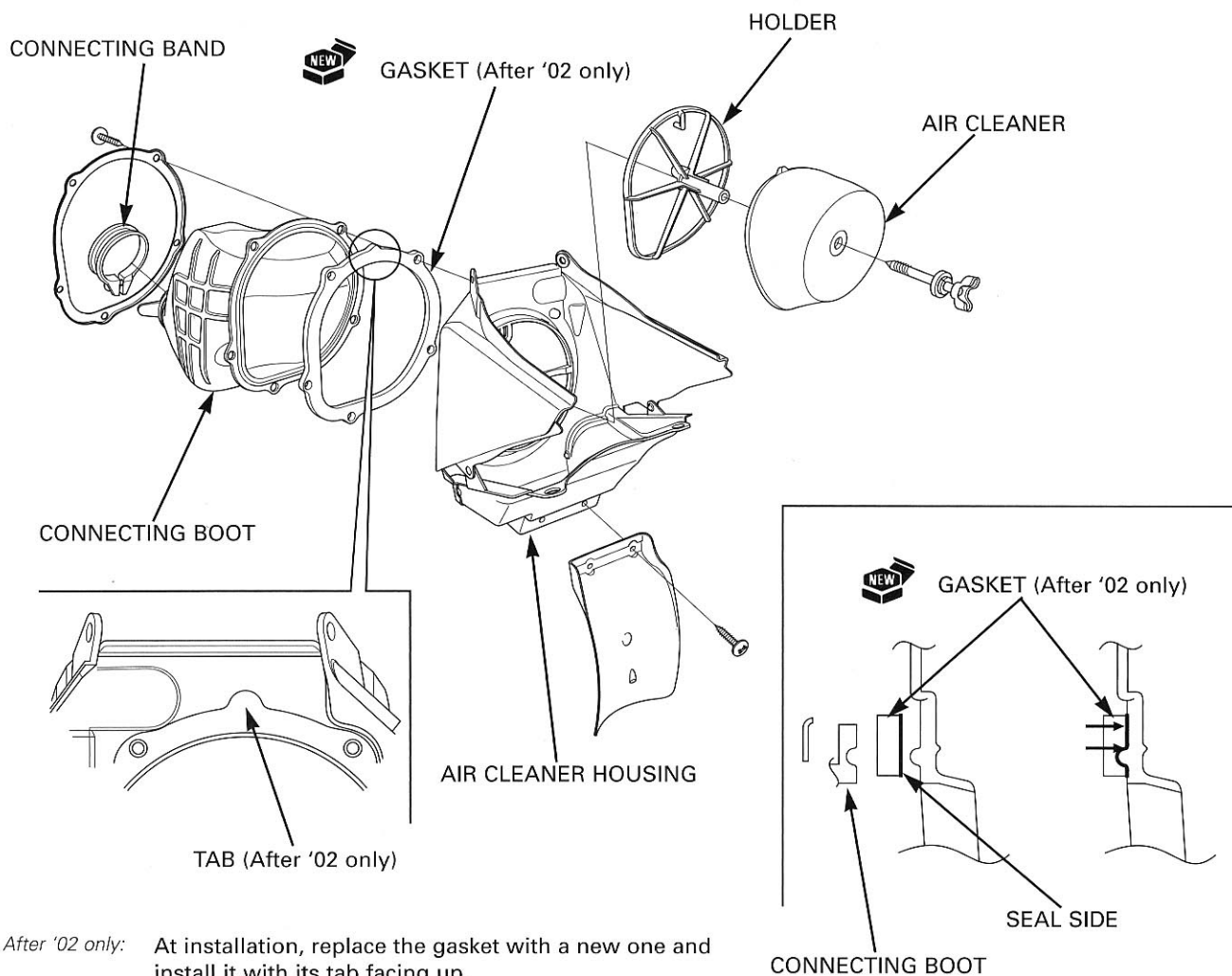

*After '02 only:* At installation, replace the gasket with a new one and install it with its tab facing up.

**COOLING SYSTEM**

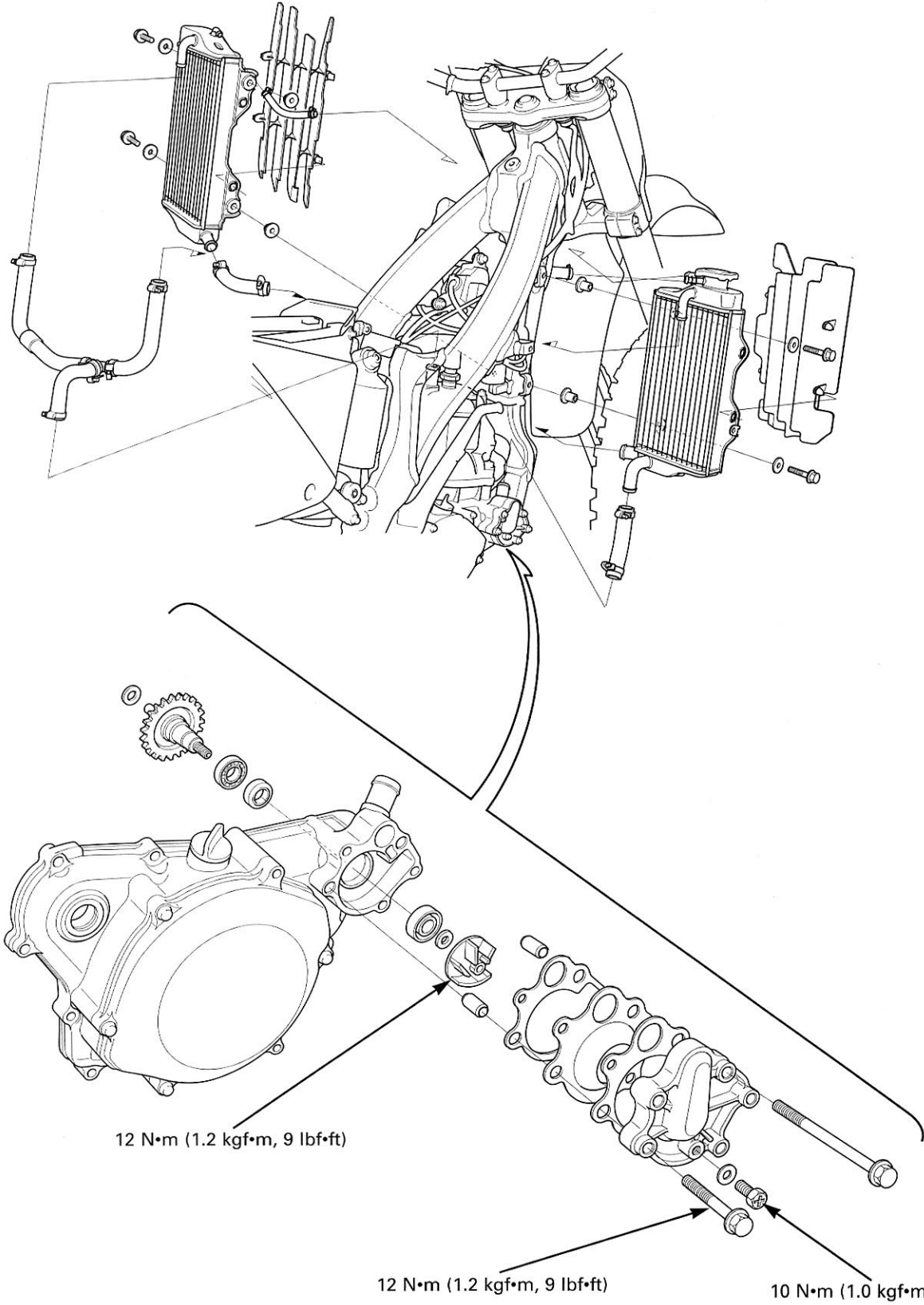

# 5. COOLING SYSTEM

SERVICE INFORMATION	5-1	COOLANT REPLACEMENT	5-4
TROUBLESHOOTING	5-2	RADIATOR	5-5
COOLING SYSTEM TESTING	5-3	WATER PUMP	5-7

## SERVICE INFORMATION

### GENERAL

#### **⚠ CAUTION**

**5**

Removing the radiator cap while the engine is hot can allow the coolant to spray out, seriously scalding you. Always let the engine and radiator cool down before removing the radiator cap.

#### **NOTICE**

Using coolant with silicate corrosion inhibitors may cause premature wear of water pump seals or blockage of radiator passages. Using tap water may cause engine damage.

- Use only distilled water and ethylene glycol in the cooling system. A 1:1 mixture is recommended for maximum corrosion protection. Do not use alcohol-based antifreeze.
- All cooling system services can be done with the engine in the frame.
- Avoid spilling coolant on painted surfaces.
- After servicing the system, check for leaks with a cooling system tester.
- If any coolant gets in your eyes, rinse them with water and consult a physician immediately.
- If any coolant is swallowed, induce vomiting, gargle and consult a physician immediately.
- If any coolant gets on your skin or clothes, rinse thoroughly with plenty of water.
- Recycle used coolant in an ecologically correct manner.

### SPECIFICATIONS

ITEM		SPECIFICATIONS
Coolant capacity	At change	1.08 liter (1.14 US qt, 0.95 Imp qt)
	At disassembly	1.15 liter (1.22 US qt, 1.01 Imp qt)
Radiator cap relief pressure		108 – 137 kPa (1.1 – 1.4 kgf/cm <sup>2</sup> , 16 – 20 psi)
Recommended antifreeze		Pro Honda HP coolant or equivalent high quality ethylene glycol antifreeze containing silicate-free corrosion inhibitors
Standard coolant concentration		1:1 mixture with soft water

### TORQUE VALUES

Water pump impeller	12 N•m (1.2 kgf•m, 9 lbf•ft)
Coolant drain bolt	10 N•m (1.0 kgf•m, 7 lbf•ft)
Water pump cover bolt	12 N•m (1.2 kgf•m, 9 lbf•ft)

## COOLING SYSTEM

---

### TOOLS

Pilot, 12 mm	07746-0040200
Pilot, 17 mm	07746-0040400
Driver	07749-0010000
Bearing remover set, 12 mm	07936-1660001 Not available in U.S.A.
— Remover weight	07741-0010201 or 07936-3710200 or 07936-371020A
— Remover, 12 mm	07936-1660101 or 07936-166010A (U.S.A. only)
— Remover head, 12 mm	07936-1660110 Not available in U.S.A.
— Remover shaft	07936-1660120 Not available in U.S.A.
Water seal driver	07945-KA30000 or GN-AH-065-415 or 07965-415000A (U.S.A. only)
Attachment, 28 x 30 mm	07946-1870100

### TROUBLESHOOTING

#### Engine temperature too high

- Faulty radiator cap
- Insufficient coolant
- Passages blocked in radiator, hoses or water jacket
- Radiator air passages clogged with dirt
- Air in system
- Faulty water pump

#### Coolant leak

- Faulty water pump oil and water seal
- Deteriorated water pump oil and water seal
- Damaged or deteriorated gasket
- Loose hose connection or clamp
- Damaged or deteriorated hose
- Faulty radiator cap
- Damaged radiator

# COOLING SYSTEM TESTING

## COOLANT (HYDROMETER TEST)

*The engine must be cool before removing the radiator cap, or severe scalding may result.*

Remove the radiator cap.

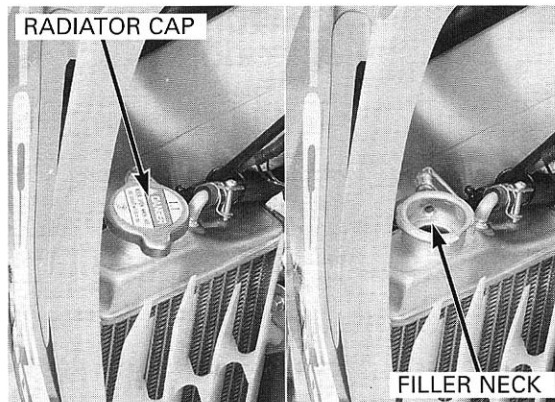

Test the coolant mixture with a hydrometer (see below for "Coolant specific gravity chart"). For maximum corrosion protection, a 1:1 solution of ethylene glycol and distilled water is recommended (page 5-4). Look for contamination and replace the coolant if necessary.

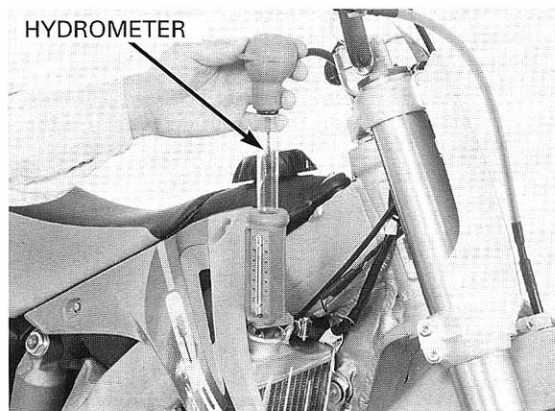

**Coolant specific gravity chart**

Coolant temperature °C (°F)	0 (32)	5 (41)	10 (50)	15 (59)	20 (68)	25 (77)	30 (86)	35 (95)	40 (104)	45 (113)	50 (122)
Coolant ratio %											
5	1.009	1.009	1.008	1.008	1.007	1.006	1.005	1.003	1.001	0.999	0.997
10	1.018	1.017	1.017	1.016	1.015	1.014	1.013	1.011	1.009	1.007	1.005
15	1.028	1.027	1.026	1.025	1.024	1.022	1.020	1.018	1.016	1.014	1.012
20	1.036	1.035	1.034	1.033	1.031	1.029	1.027	1.025	1.023	1.021	1.019
25	1.045	1.044	1.043	1.042	1.040	1.038	1.036	1.034	1.031	1.028	1.025
30	1.053	1.052	1.051	1.047	1.046	1.045	1.043	1.041	1.038	1.035	1.032
35	1.063	1.062	1.060	1.058	1.056	1.054	1.052	1.049	1.046	1.043	1.040
40	1.072	1.070	1.068	1.066	1.064	1.062	1.059	1.056	1.053	1.050	1.047
45	1.080	1.078	1.076	1.074	1.072	1.069	1.066	1.063	1.060	1.057	1.054
50	1.086	1.084	1.082	1.080	1.077	1.074	1.071	1.068	1.065	1.062	1.059
55	1.095	1.093	1.091	1.088	1.085	1.082	1.079	1.076	1.073	1.070	1.067
60	1.100	1.098	1.095	1.092	1.089	1.086	1.083	1.080	1.077	1.074	1.071

## COOLING SYSTEM

### RADIATOR CAP/SYSTEM PRESSURE INSPECTION

Remove the radiator cap (page 5-3).

*Wet the sealing surface with water.*

Install the radiator cap on the tester.

Pressure test the radiator cap.  
Replace the radiator cap if it does not hold pressure, or if relief pressure is too high or too low.  
It must hold specified pressure for at least 6 seconds.

**RADIATOR CAP RELIEF PRESSURE:**  
108 – 137 kPa (1.1 – 1.4 kgf/cm<sup>2</sup>, 16 – 20 psi)

*Excessive pressure can damage the cooling system components. Do not exceed 137 kPa (1.4 kgf/cm<sup>2</sup>, 20psi).*

Pressurize the radiator, engine and hoses, and check for leaks.

Repair or replace components if the system will not hold the specified pressure for at least 6 seconds.



## COOLANT REPLACEMENT

### PREPARATION

The effectiveness of coolant decreases with the accumulation of rust or if there is a change in the mixing proportion during usage. Therefore, for best performance change the coolant regularly as specified in the maintenance schedule.  
Mix only distilled, low mineral water with the antifreeze.

**RECOMMENDED MIXTURE:**  
1:1 (distilled water and antifreeze)

**RECOMMENDED ANTIFREEZE:**  
Pro Honda HP coolant or an equivalent high quality ethylene glycol antifreeze containing silicate-free corrosion inhibitors

### NOTICE

*Using coolant with silicate corrosion inhibitors may cause premature wear of water pump seals or blockage of radiator passages. Using tap water may cause engine damage.*

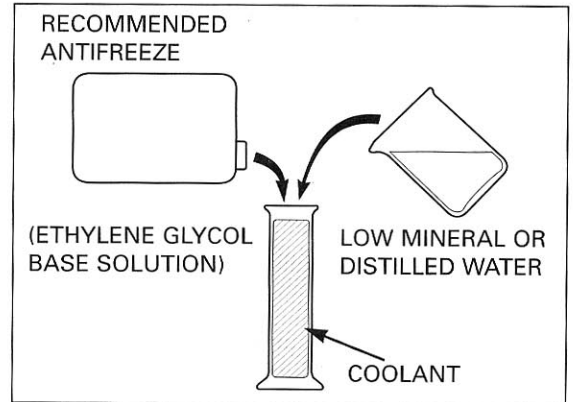

## REPLACEMENT/AIR BLEEDING

When filling the system, place the motorcycle in a vertical position on a flat, level surface.

*The engine must be cool before removing the radiator cap, or severe scalding may result.*

Remove the radiator cap.

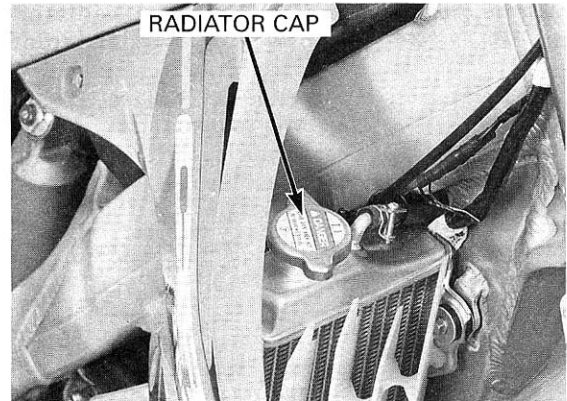

Remove the drain bolt on the water pump cover and then drain the system coolant.

Reinstall the drain bolt with a new sealing washer. Tighten the drain bolt to the specified torque.

**TORQUE: 10 N·m (1.0 kgf·m, 7 lbf·ft)**

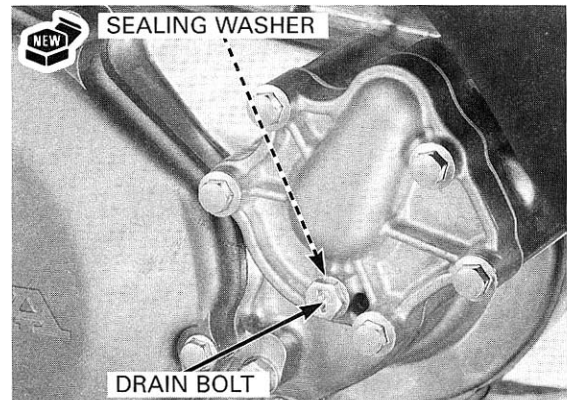

Fill the system with the recommended coolant through the filler opening, up to filler neck.

**CAPACITY: 1.08 liter (1.14 US oz, 0.95 Imp oz)**

Lean the machine approximately 20° to the right and left several times to bleed any air trapped in the cooling system. If the coolant level drops, add more coolant and repeat the air bleeding procedure.

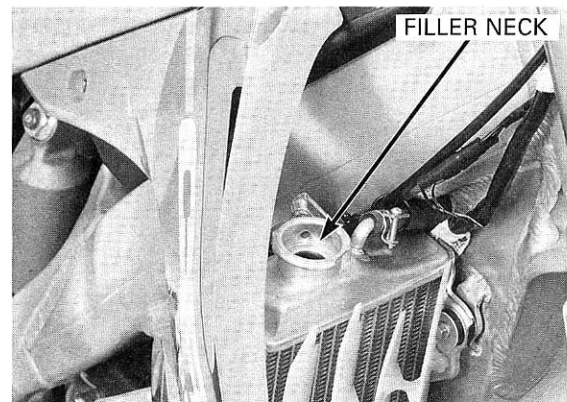

## RADIATOR

### REMOVAL

Drain the coolant (see above).  
Remove the fuel tank (page 2-5).  
Remove the expansion chamber (page 2-6).

Remove the right and left radiator grills.

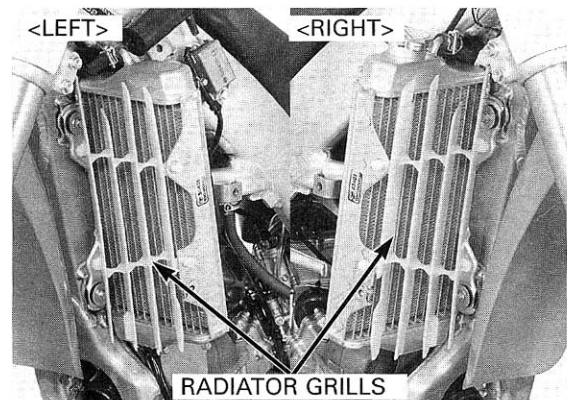



## COOLING SYSTEM

*Note the direction of the hose clamp.*

Loosen the upper radiator hose clamps and disconnect the upper radiator hoses.

Loosen the lower radiator hose clamp and disconnect the lower radiator hose.

Loosen the upper and lower joint hose clamps and disconnect the upper and lower joint hoses.

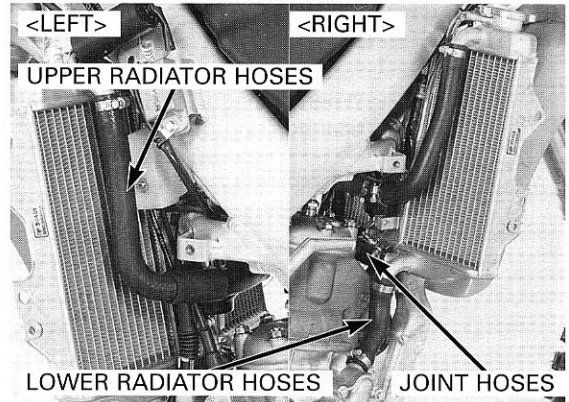

*Be careful not to damage the radiator core.*

Remove the upper and lower mounting bolts and collars. Remove the radiator.

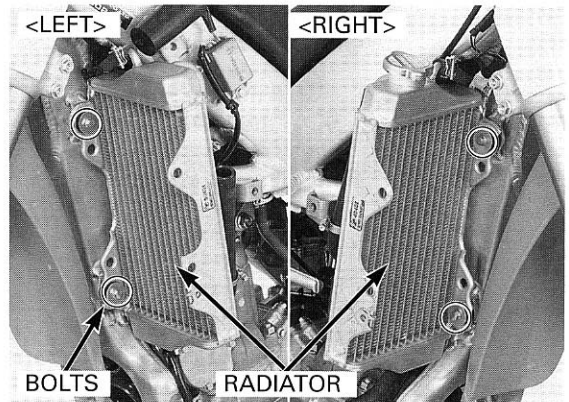

## INSTALLATION

When connecting the upper radiator hose, allow space for the ignition coil.

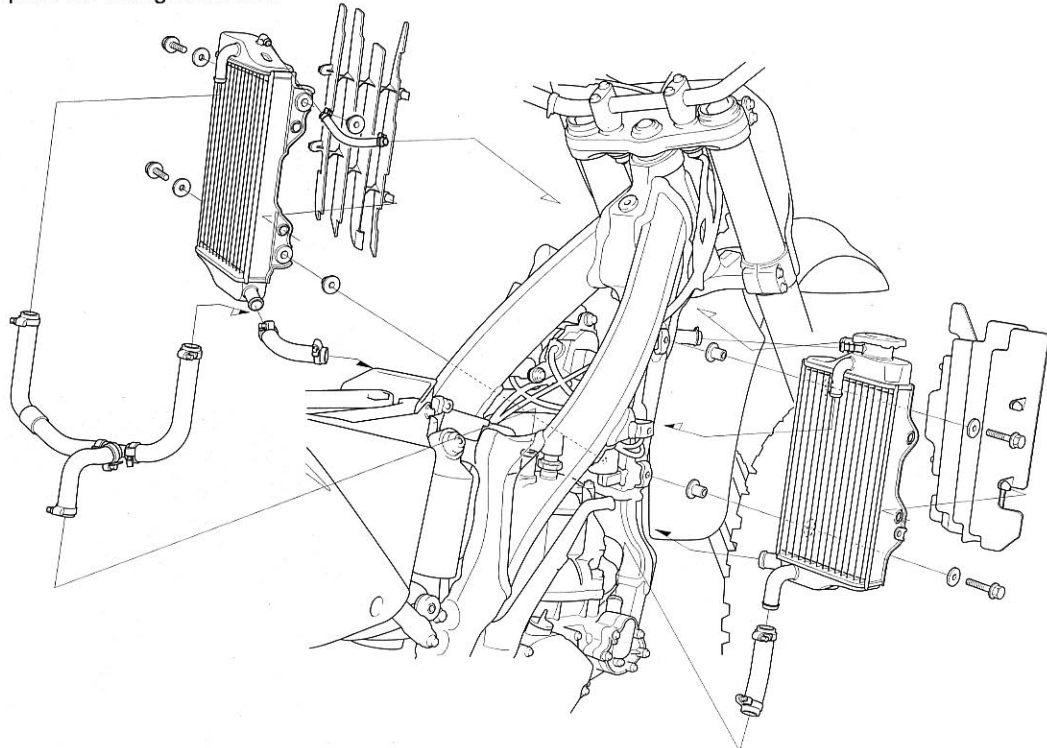

Installation is essentially the reverse order of removal.

Add the recommend coolant mixture up to the filler neck and bleed the air (page 5-4).

After installation, check the radiator and radiator hoses for leaks.

Install the expansion chamber (page 2-6).  
Install the fuel tank (page 2-5).

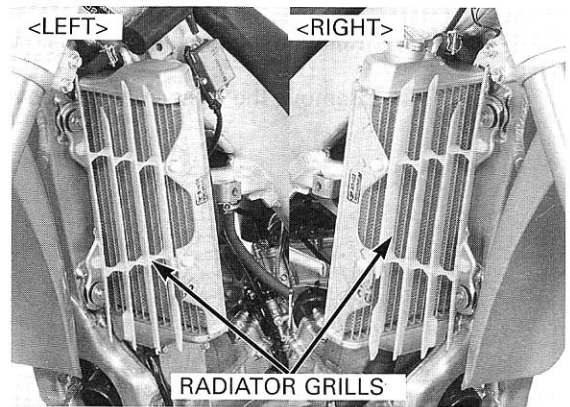

## WATER PUMP

### MECHANICAL SEAL INSPECTION

Inspect the telltale hole for signs of coolant leakage. If there is leakage, the mechanical seal is defective and replace the water pump as an assembly.

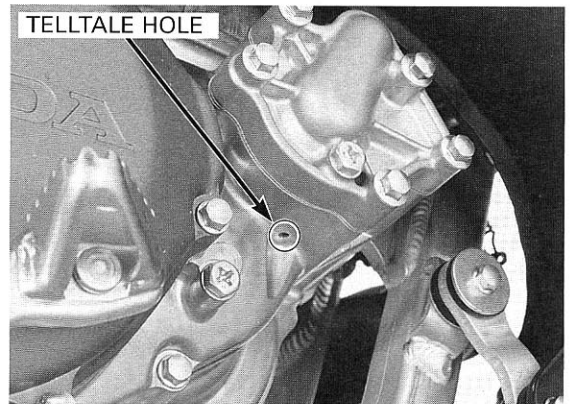

### REMOVAL

Drain the coolant (page 5-5).

Remove the five flange bolts and water pump cover.

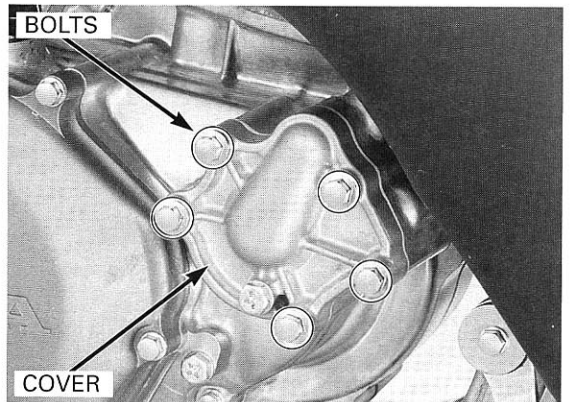

Remove the outer gasket and plate.

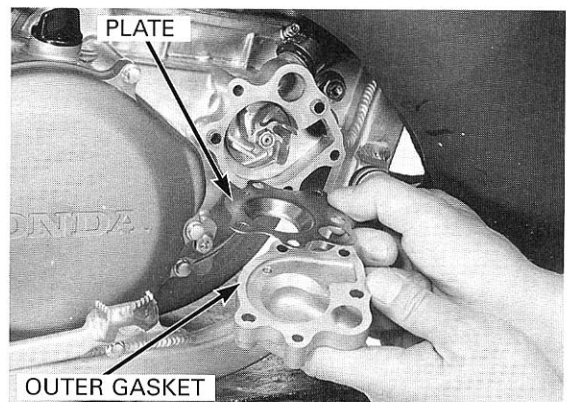

## COOLING SYSTEM

Remove the inner gasket and dowel pins.  
Remove the impeller and plain washer.

Remove the right crankcase cover (page 9-3).

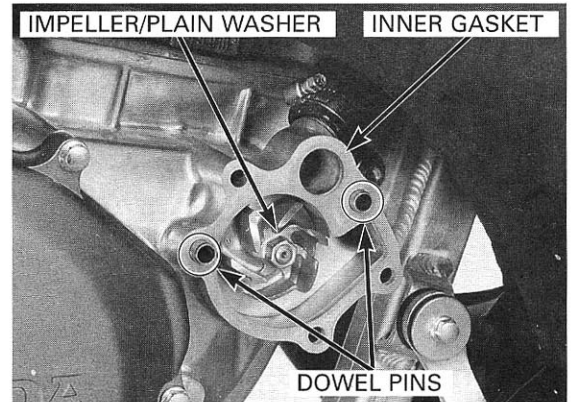

Remove the water pump shaft from the right crankcase cover.

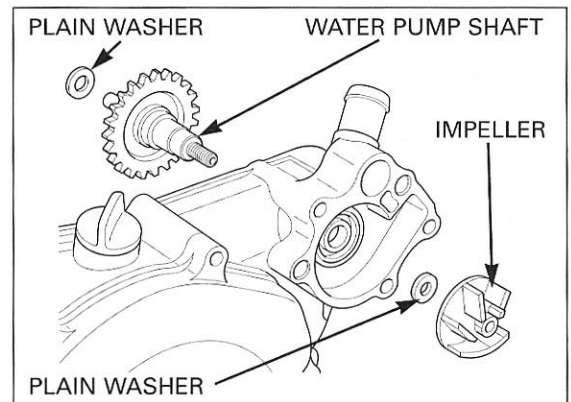

Check the water pump shaft and gear to be sure they are not bent or damaged.

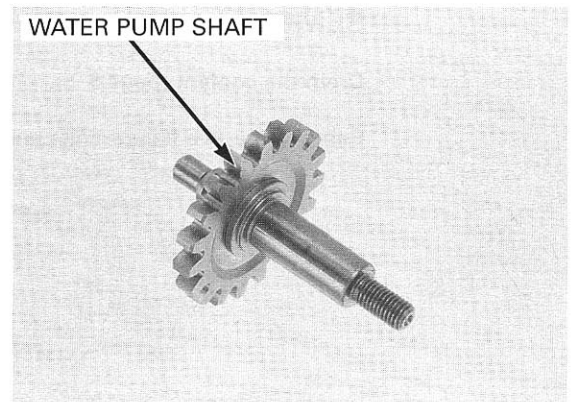

Check the water pump shaft sliding surface in the right crankcase for wear or damage.

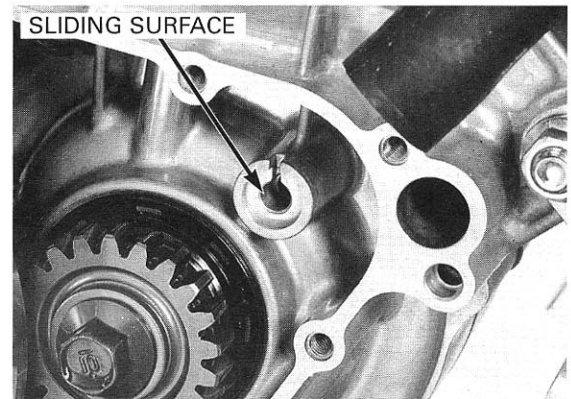

Turn the inner race of the water pump shaft bearing with your finger. The bearing should turn smoothly and quietly. Also check that the bearing outer race fits tightly in the right crankcase cover.

Replace the water pump shaft bearing if necessary (page 5-10).

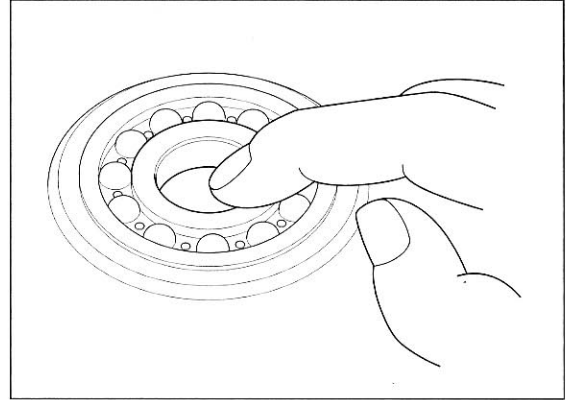

Check the water seal for damage or deterioration.

Replace the water seal if necessary (page 5-10).

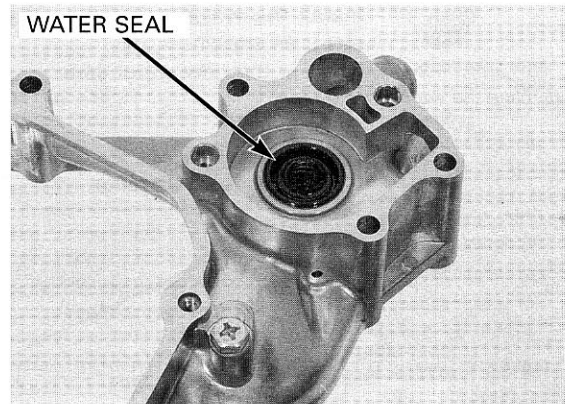

## BEARING REPLACEMENT

Remove the water pump shaft bearing using the special tools.

### TOOLS:

<b>Bearing remover set, 12 mm</b>	<b>07936-166001</b> Not available in U.S.A.
— Remover weight	07741-0010201 or 07936-3710200 or 07936-371020A
— Remover, 12 mm	07936-1660101 or 07936-166010A (U.S.A. only)
— Remover head, 12 mm	07936-1660110
— Remover shaft	07936-1660120

Check the oil seal for damage or deterioration.

Replace the oil seal if necessary.

Remove the oil seal.

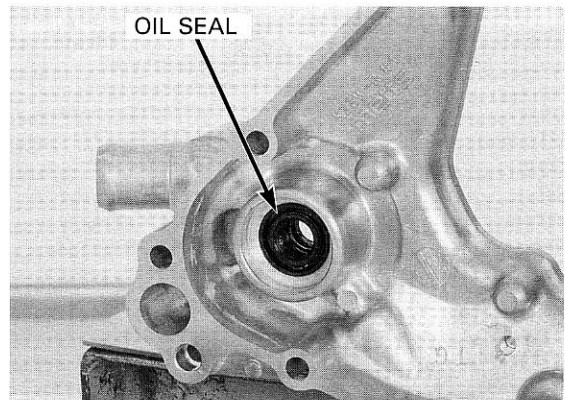
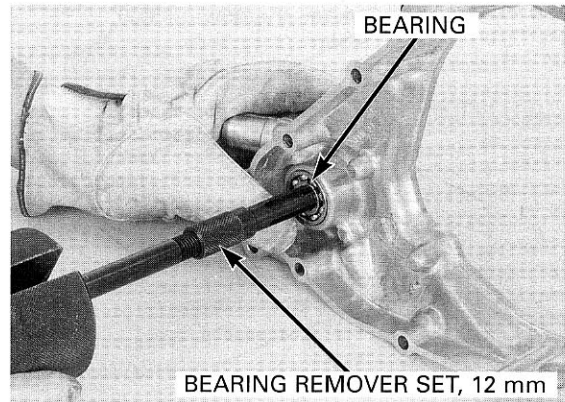

## COOLING SYSTEM

Drive out the water seal from the right crankcase cover.

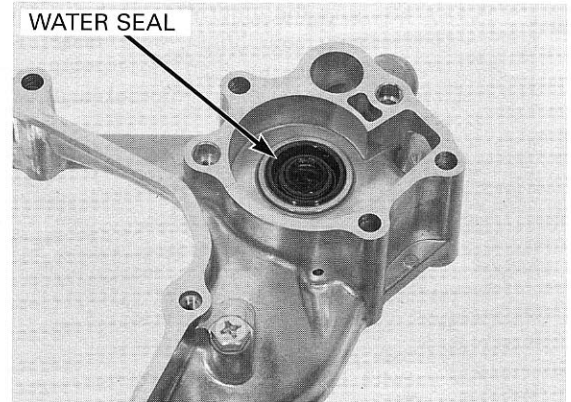

Install the water seal driver into the right crankcase cover as shown.

Drive in the new water seal.

*Be careful not to damage the water seal lips.*

**TOOLS:**

**Water seal driver**  
**Mechanical seal installer**

07945-KA30000 or  
GN-AH-065-415 or  
07965-415000A  
(U.S.A. only)

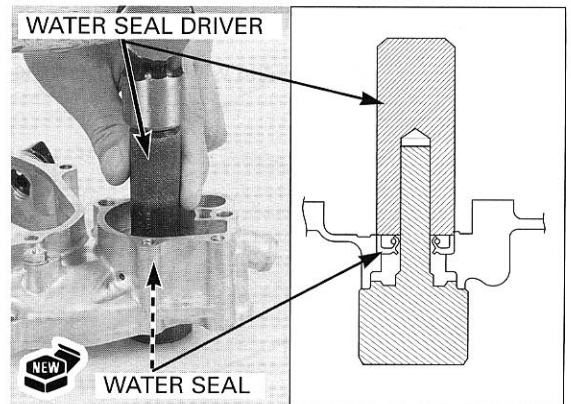

Install the new oil seal.

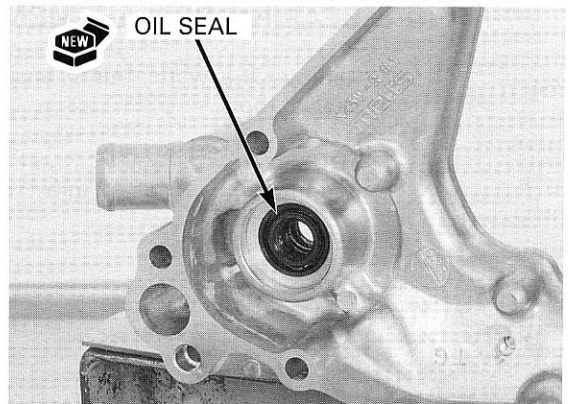

Drive in the new bearing into the right crankcase cover using the special tools as shown.

**TOOLS:**

**Driver**  
**Attachment, 28 x 30 mm**  
**Pilot, 12 mm**

07749-0010000  
07946-1870100  
07746-0040200

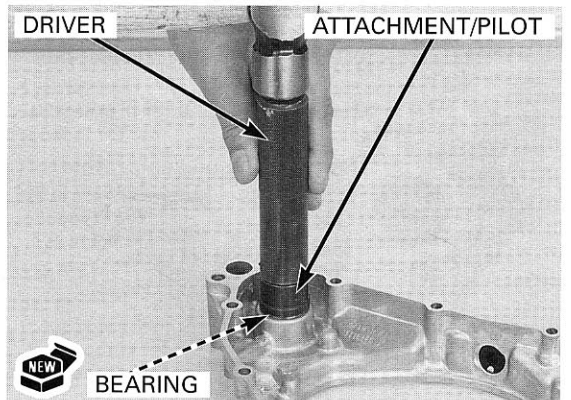

INSTALLATION

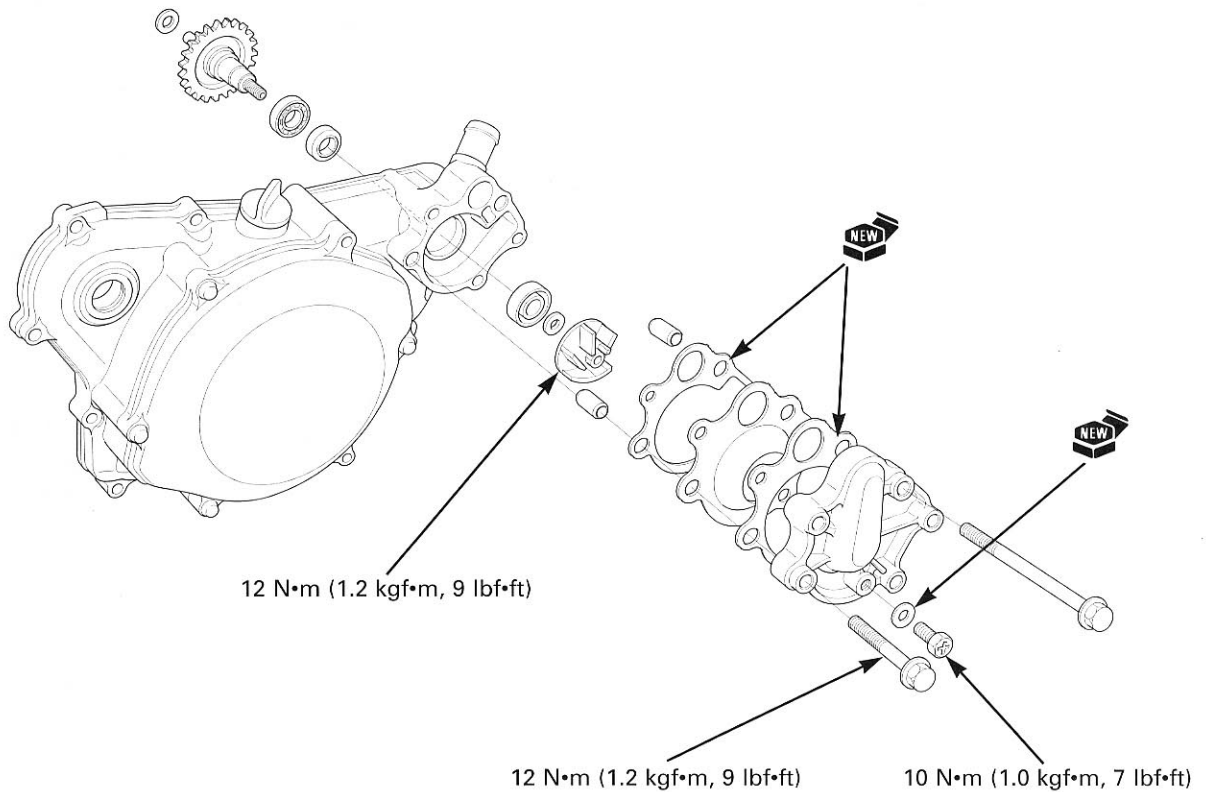

Install the water pump shaft to the right crankcase cover.  
 Install the copper washers onto the water pump shaft.  
 Install the right crankcase (page 9-3).

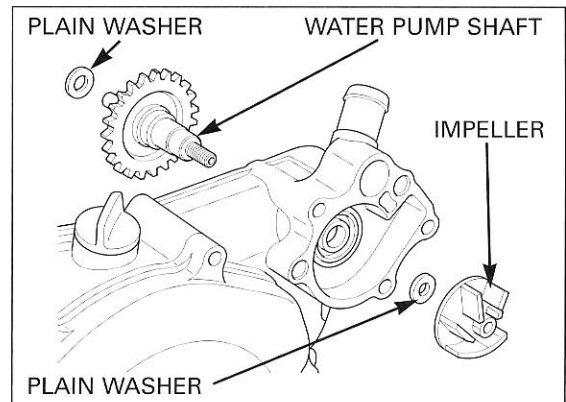

Install the plain washer and impeller onto the water pump shaft.  
 Tighten the impeller to the specified torque.

**TORQUE: 12 N·m (1.2 kgf·m, 9 lbf·ft)**

Install the dowel pins and new inner gasket.

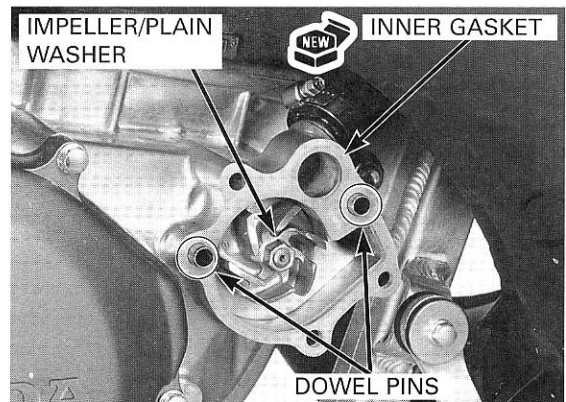

## COOLING SYSTEM

---

Install the plate and new outer gasket.

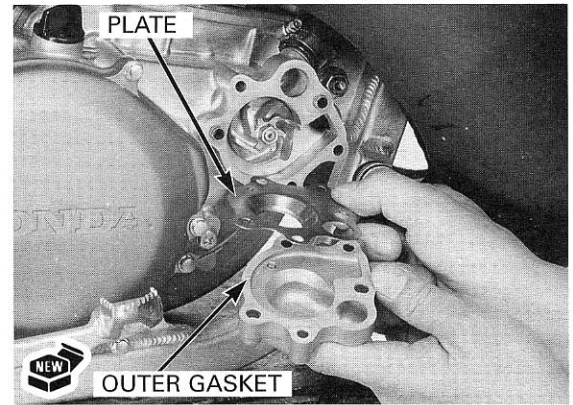

Install the water pump cover and tighten the four flange bolts to the specified torque.

**TORQUE: 12 N·m (1.2 kgf·m, 9 lbf·ft)**

Add the recommend coolant mixture to the filler neck and bleed the air (page 5-5).

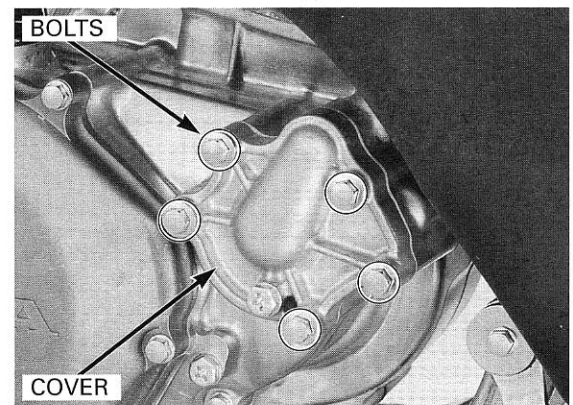

# ENGINE REMOVAL/INSTALLATION

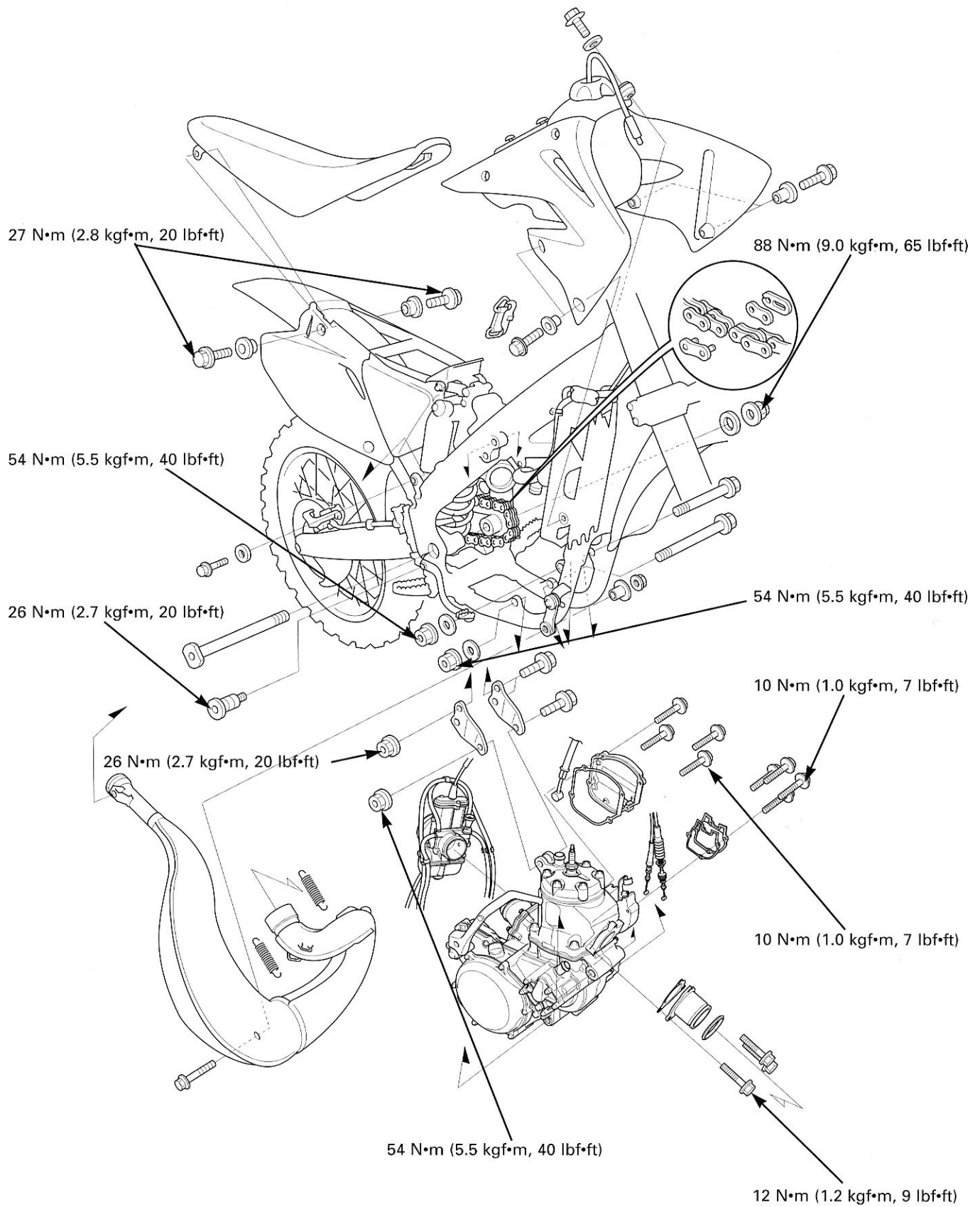



# 6. ENGINE REMOVAL/INSTALLATION

<b>SERVICE INFORMATION</b>	<b>6-1</b>	<b>ENGINE INSTALLATION</b>	<b>6-3</b>
<b>ENGINE REMOVAL</b>	<b>6-2</b>		

## SERVICE INFORMATION

### GENERAL

- During engine removal and installation, support the motorcycle using a workstand.
- The following components can be serviced with the engine installed in the frame.
  - Alternator (section 14)
  - Clutch/kickstarter/gearshift linkage (section 9)
  - Cylinder head/cylinder/piston (section 7)
  - RC valve system (section 8)
- The following components require engine removal for service.
  - Crankshaft/transmission (section 10)

6

### SPECIFICATIONS

ITEM		STANDARD
Engine dry weight		23.0 kg (50.7 lbs)
Recommended transmission oil		Pro Honda HP Trans oil, Pro Honda GN4, HP4 (without molybdenum additives) 4-stroke oil or equivalent motor oil API service classification: SG or higher except oils labeled as energy conserving on the circular API service label  Viscosity: SAE 10W-40 JASO T903: MA
Transmission oil capacity	at draining	0.65 liter (0.69 US qt, 0.57 Imp qt)
	at disassembly	0.70 liter (0.74 US qt, 0.62 Imp qt)
Coolant capacity	at change	1.08 liter (1.14 US qt, 0.95 Imp qt)
	at disassembly	1.15 liter (1.22 US qt, 1.01 Imp qt)

### TORQUE VALUES

Engine hanger plate nut		26 N•m (2.7 kgf•m, 20 lbf•ft)
Engine upper mounting nut		54 N•m (5.5 kgf•m, 40 lbf•ft)
Engine lower mounting nut	(front)	54 N•m (5.5 kgf•m, 40 lbf•ft)
	(rear)	54 N•m (5.5 kgf•m, 40 lbf•ft)
Exhaust pipe joint nut		12 N•m (1.2 kgf•m, 9 lbf•ft)
Swingarm pivot nut		88 N•m (9.0 kgf•m, 65 lbf•ft)
Alternator cover bolt		10 N•m (1.0 kgf•m, 7 lbf•ft)
Brake pedal pivot bolt		26 N•m (2.7 kgf•m, 20 lbf•ft)

## ENGINE REMOVAL/INSTALLATION

### ENGINE REMOVAL

Remove the springs, bolts, nut and expansion chamber.

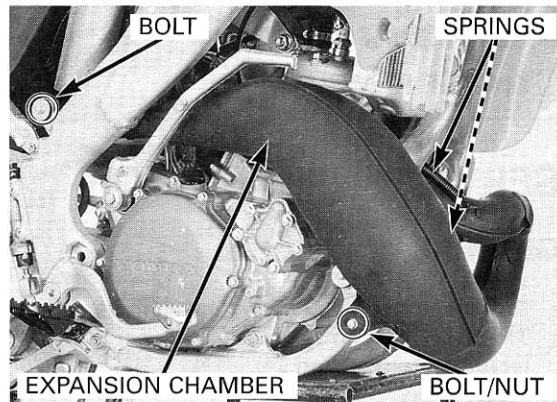

Remove the bolts, exhaust pipe joint and gasket.

Drain the transmission oil (page 3-10).  
Drain the coolant (page 5-5).  
Remove the fuel tank (page 2-5).

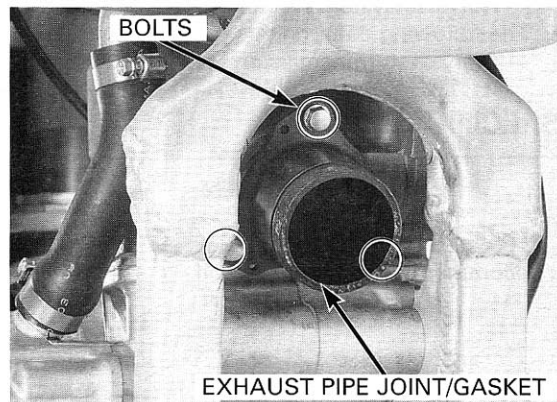

Loosen the screw and disconnect the radiator joint hose (page 5-5).  
Remove the bolts and swing the radiator forward (page 5-5).  
Remove the brake pedal pivot bolt and move the pedal aside (page 13-21).

Disconnect the lower radiator hoses.

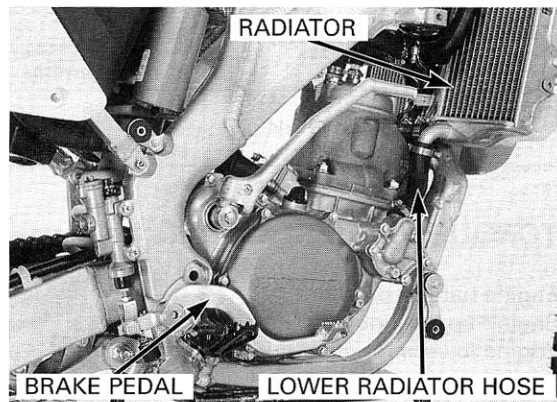

Remove the following:

- Carburetor (page 4-7)
- Spark plug cap
- Drive chain
- RC valve control cables (page 8-3)

Disconnect the alternator 4P connector.  
Remove the alternator cover and disconnect the clutch cable.

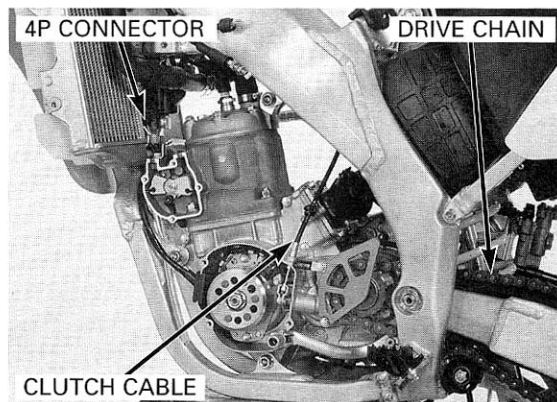

## ENGINE REMOVAL/INSTALLATION

Remove the bolts, nuts and engine hanger plates.

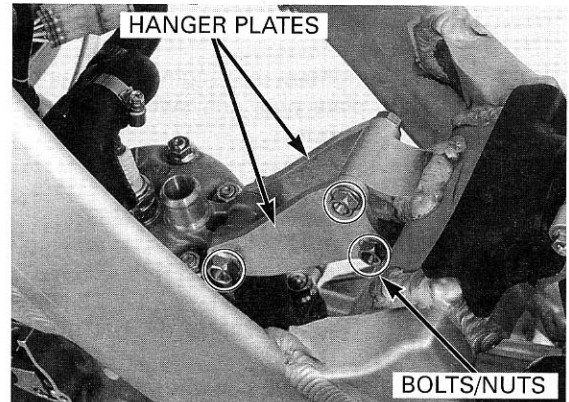

Remove the engine mounting bolts, nuts and washers.  
Remove the swingarm pivot bolt and nut.

*Note the direction  
of the engine  
mounting bolts,  
hanger plate  
bolts, and  
swingarm pivot  
bolt.*

Remove the engine from the frame.

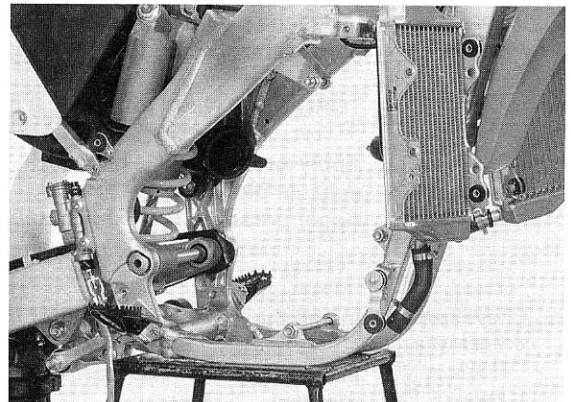
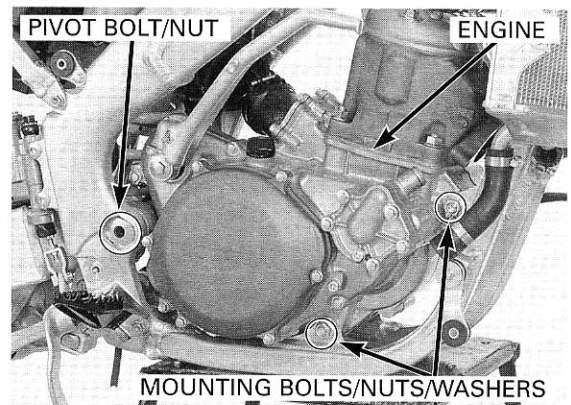

## ENGINE INSTALLATION

- Install the swingarm pivot bolt first, then install the engine mounting bolts.
- Route the wires and cables properly (page 1-17).
- Do not tighten the swingarm pivot nut and engine mounting nuts yet.

Install the engine to the frame.  
Install the swingarm pivot bolt and nut.  
Install the engine mounting bolts and nuts.

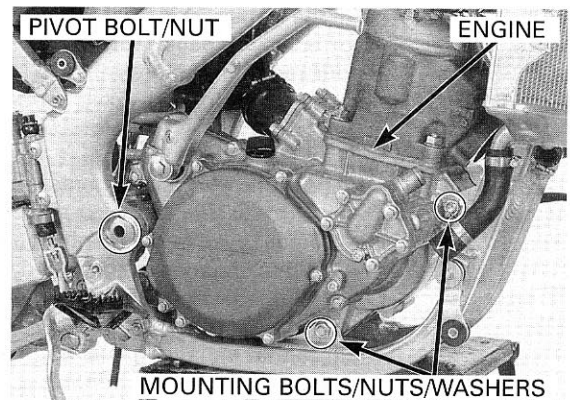

## ENGINE REMOVAL/INSTALLATION

Install the engine hanger plates, bolts and nuts.

Tighten the engine mounting nuts, engine hanger plate nuts and swingarm pivot nut to the specified torque.

### TORQUE:

#### SWINGARM PIVOT NUT:

88 N•m (9.0 kgf•m, 65 lbf•ft)

#### ENGINE HANGER PLATE NUT:

26 N•m (2.7 kgf•m, 20 lbf•ft)

#### ENGINE UPPER MOUNTING NUT:

54 N•m (5.5 kgf•m, 40 lbf•ft)

#### ENGINE LOWER MOUNTING NUTS:

54 N•m (5.5 kgf•m, 40 lbf•ft)

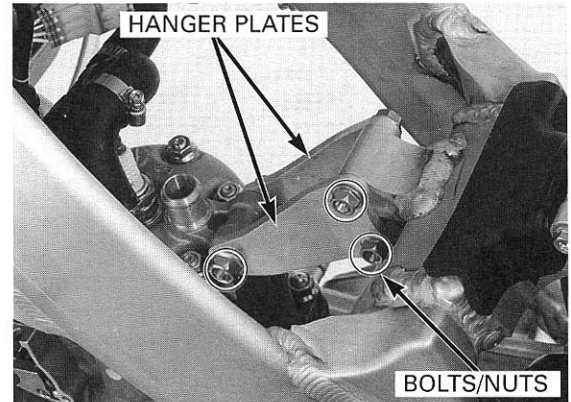

Install a new gasket.

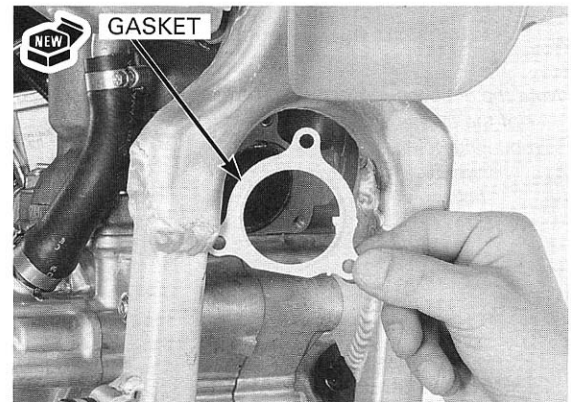

Install the exhaust pipe joint as shown and tighten the nuts to the specified torque.

### TORQUE: 12 N•m (1.2 kgf•m, 9 lbf•ft)

Apply grease to the new O-ring and install it to the exhaust pipe joint.

Apply grease to the exhaust pipe joint outer surface.

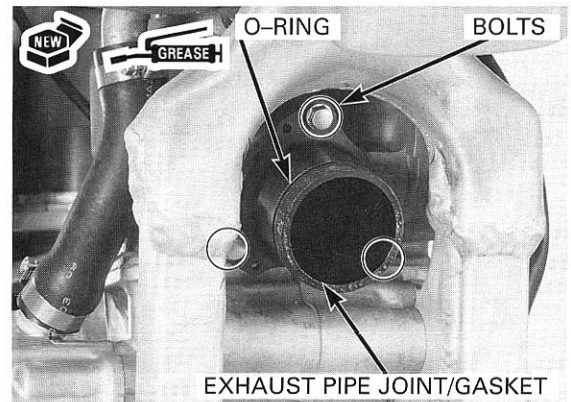

*Always install a new gasket and O-ring when installing the expansion chamber.*

Install the expansion chamber (page 2-7).

Install the removed parts in the reverse order of removal.

Fill the transmission with the recommended oil to the correct level (page 3-10).

Pour radiator coolant mixture into the radiator to the correct level (page 5-5).

After installing the engine, perform the following inspections and adjustments:

- Throttle grip free play adjustment (page 3-5)
- Rear brake pedal height (page 3-15)
- Drive chain slack (page 3-11)
- Clutch lever free play (page 3-15)

Check that exhaust gas is not leaking past the expansion chamber connection.

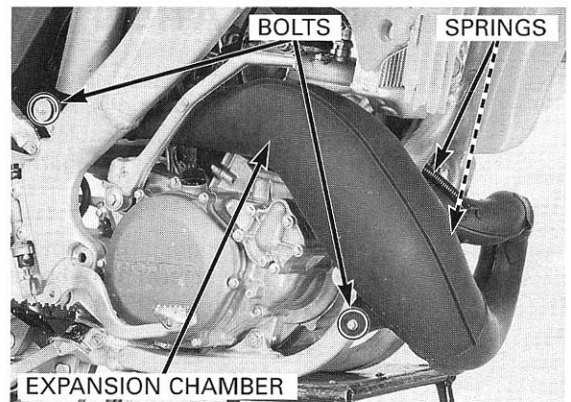

# CYLINDER HEAD/CYLINDER/PISTON

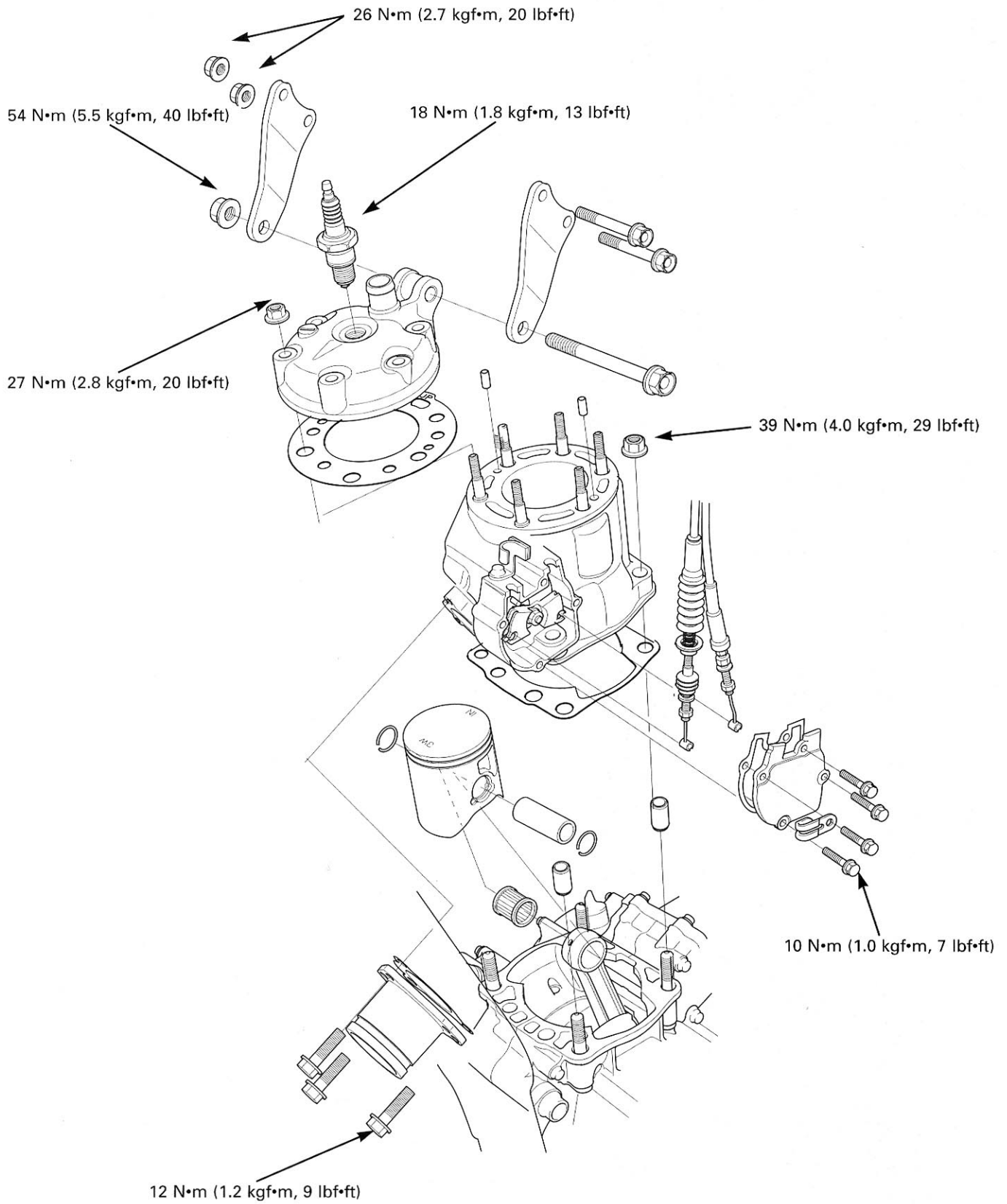

# 7. CYLINDER HEAD/CYLINDER/PISTON

<b>SERVICE INFORMATION</b>	<b>7-1</b>	<b>CYLINDER HEAD</b>	<b>7-3</b>
<b>TROUBLESHOOTING</b>	<b>7-2</b>	<b>CYLINDER, PISTON</b>	<b>7-5</b>

## SERVICE INFORMATION

### GENERAL

- This section covers service of the cylinder head, cylinder and piston. These procedures can be done with the engine in the frame.
- Before disassembling, clean the engine thoroughly to keep dirt from entering the engine.
- Do not use a screwdriver to remove the cylinder head.
- Clean all disassembled parts with cleaning solvent and dry them by blowing them off with compressed air before inspection.
- Before assembling, apply clean Pro Honda HP2 2-stroke engine oil to all sliding surfaces.
- Under racing conditions, the piston and piston rings should be replaced after 7.5 hours of operation. Replace the piston pin and connecting rod small end bearing after 22.5 hours of operation.
- When replacing the cylinder, the new cylinder will come furnished with select fitted flap valves and flap valve shaft, do not replace these with the old parts.
- Refer to section 4 for reed valve servicing.
- Refer to section 8 for RC VALVE system decarbonizing, disassembly and assembly.

**7**

### SPECIFICATIONS

Unit: mm (in)

ITEM		STANDARD	SERVICE LIMIT
Cylinder head warpage		—	0.05 (0.002)
Cylinder	I.D.	A	66.398 – 66.405 (2.6141 – 2.6244)
		B	66.390 – 66.398 (2.6138 – 2.6141)
	Out-of-round		—
	Taper		—
	Warpage		—
Piston, piston rings	Piston mark direction		"IN" mark facing toward the intake side
	Piston O.D.	A	66.330 – 66.338 (2.6114 – 2.6117)
		B	66.323 – 66.330 (2.6111 – 2.6114)
	Piston O.D. measurement point		15 – 25 mm (0.59 – 0.98 in) from bottom of skirt
	Piston pin bore I.D.		18.007 – 18.013 (0.7089 – 0.7092)
	Piston pin O.D.		17.994 – 18.000 (0.7084 – 0.7087)
	Piston-to-piston pin clearance		0.007 – 0.019 (0.0003 – 0.0007)
	Piston ring-to-ring groove clearance	Top	0.045 – 0.075 (0.002 – 0.003)
		Second	0.025 – 0.055 (0.001 – 0.002)
Piston ring end gap		0.40 – 0.55 (0.016 – 0.022)	
Cylinder-to-piston clearance		0.060 – 0.075 (0.0024 – 0.0029)	
Connecting rod small end I.D.		21.997 – 22.009 (0.8660 – 0.8665)	

## CYLINDER HEAD/CYLINDER/PISTON

---

### TORQUE VALUES

Engine hanger plate nut	26 N•m (2.7 kgf•m, 20 lbf•ft)
Engine upper mounting nut	54 N•m (5.5 kgf•m, 40 lbf•ft)
Spark plug	18 N•m (1.8 kgf•m, 13 lbf•ft)
Cylinder head nut	27 N•m (2.8 kgf•m, 20 lbf•ft)
Cylinder mounting nut	39 N•m (4.0 kgf•m, 29 lbf•ft)
Cylinder stud bolt	12 N•m (1.2 kgf•m, 9 lbf•ft)
Exhaust pipe joint bolt	12 N•m (1.2 kgf•m, 9 lbf•ft)
Flap valve shaft nut	10 N•m (1.0 kgf•m, 7 lbf•ft)
RC valve cover bolt	10 N•m (1.0 kgf•m, 7 lbf•ft)
RC valve stopper plate socket bolt	10 N•m (1.0 kgf•m, 7 lbf•ft)

### TROUBLESHOOTING

- Engine top–end problems usually affect engine performance. These problems can be diagnosed by a compression test or by tracing engine noises to the top-end with a sounding rod or stethoscope.

#### **Compression too low, hard starting or poor performance at low speed**

- Blown cylinder head gasket
- Loose spark plug
- Worn, stuck or broken piston ring
- Worn or damaged cylinder and piston
- Faulty reed valve
- Worn crankshaft seals

#### **Compression too high, overheating or knocking**

- Excessive carbon build–up on top of piston or in combustion chamber

#### **Abnormal noise – piston**

- Worn or cracked piston
- Worn cylinder and piston
- Worn piston pin or piston pin hole
- Worn connecting rod small end bearing

#### **Abnormal noise – piston ring**

- Worn, stuck or broken piston ring
- Worn or damaged cylinder

#### **Contaminated coolant**

- Leaking cylinder head gasket

## CYLINDER HEAD

### REMOVAL

Drain the radiator coolant (page 5-5).  
Remove the seat and fuel tank (page 2-2, 5).

*Note the direction  
of the hose  
clamp.*

Loosen the radiator hose clamp and remove the radiator hose from the cylinder head.

Remove the spark plug cap.

Remove the spark plug.  
Remove the engine upper hanger plate bolts, nuts  
and hanger plates.

To avoid warping the cylinder head, use a crisscross  
pattern to loosen each nut about 1/4 turn in two or  
three steps, then remove the cylinder head nuts.

Remove the cylinder head.

Remove the cylinder head gasket.  
Remove the dowel pins.

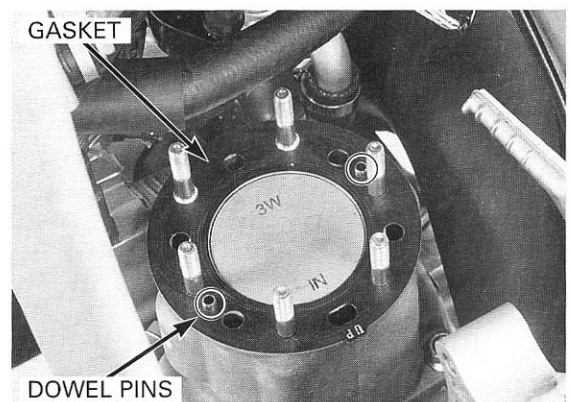
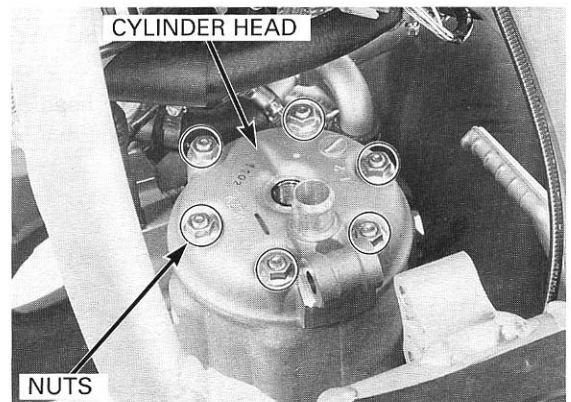
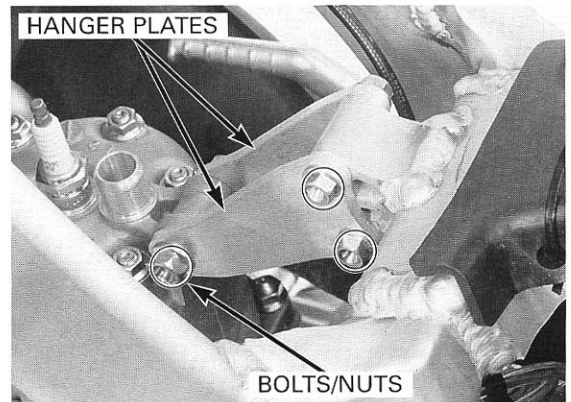
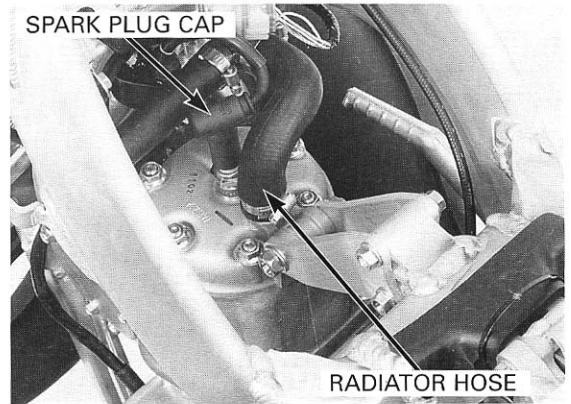



## CYLINDER HEAD/CYLINDER/PISTON

### INSPECTION

*Be careful not to damage the cylinder head.*

Clean the head gasket surface of any gasket material. Remove the carbon deposits from the combustion chamber.

Check the cylinder head for warpage in diagonal directions using a straight edge and feeler gauge.

**SERVICE LIMIT: 0.05 mm (0.002 in)**

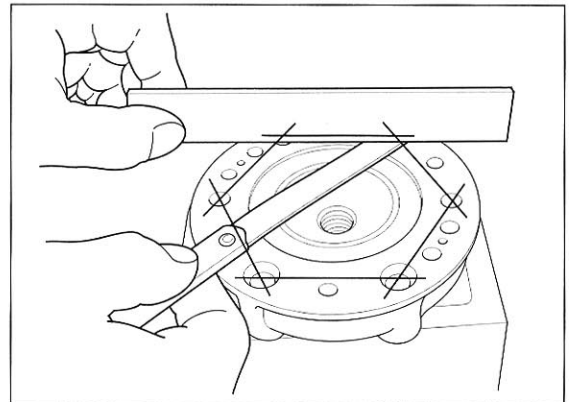
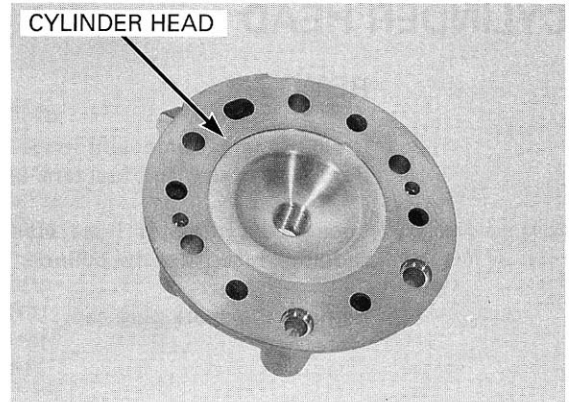

### INSTALLATION

Install the dowel pins.  
Install the new cylinder head gasket with the "UP" mark facing up and to the rear.

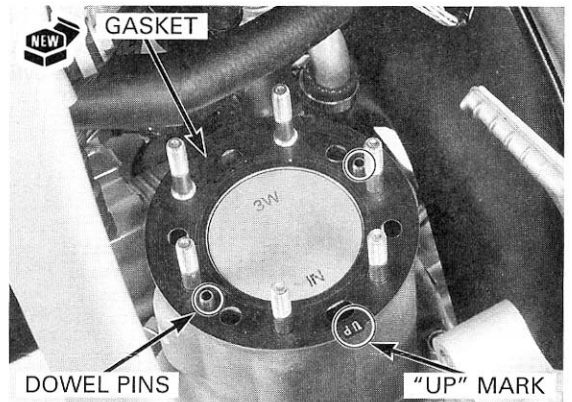

Place the cylinder head on the cylinder.  
Tighten the five cylinder head nuts in a crisscross pattern in two or three steps.  
Then tighten the nuts to the specified torque.

**TORQUE: 27 N•m (2.8 kgf•m, 20 lbf•ft)**

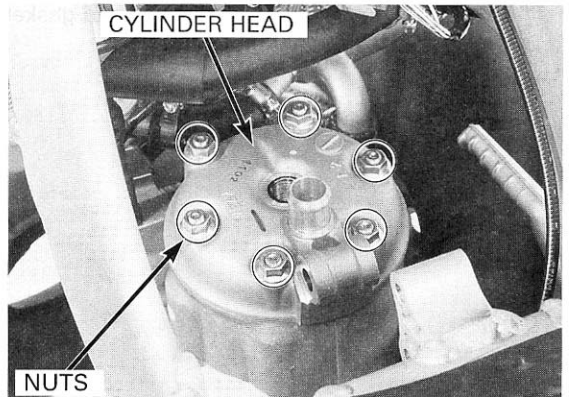

Install the engine upper hanger brackets and bolts/nuts.

Tighten the mounting nuts to the specified torque.

**TORQUE:** Engine hanger plate nut:  
26 N·m (2.7 kgf·ft, 20 lbf·ft)  
Engine mounting nut:  
54 N·m (5.5 kgf·ft, 40 lbf·ft)

Install the spark plug.

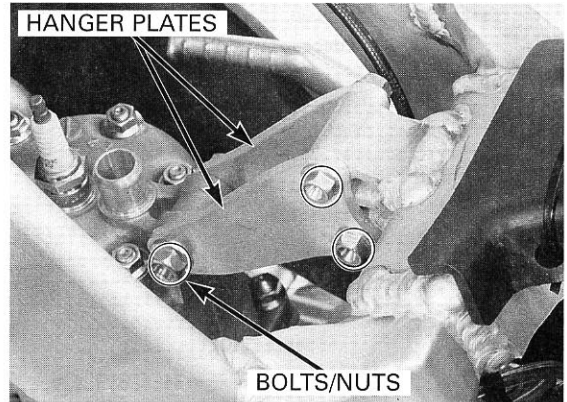

Install the spark plug cap.

Connect the radiator hose to the cylinder head.

*Note the direction of the hose clamp. Make a space between the hose and ignition coil.*

Add the recommend coolant mixture into the radiator to the correct level (page 5-5).

Install the fuel tank and seat (page 2-2, 5).

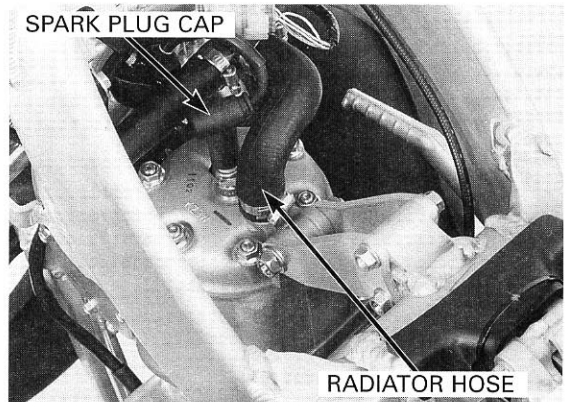

## CYLINDER, PISTON

### CYLINDER REMOVAL

Remove the cylinder head (page 7-3).  
Remove the expansion chamber (page 2-6).  
Disconnect the RC valve cables (page 8-3).

Remove the bolts, exhaust pipe joint and gasket.

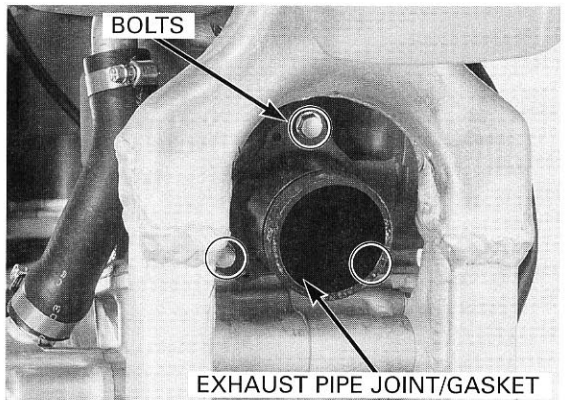
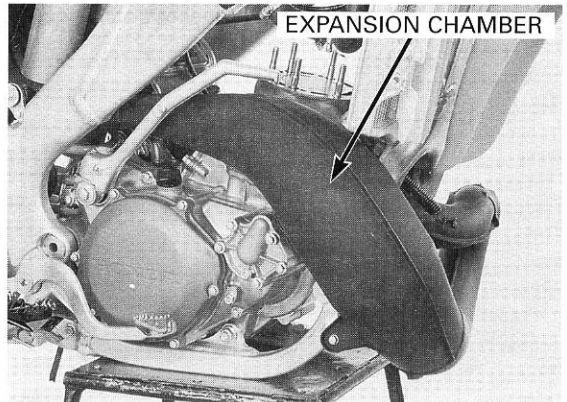

## CYLINDER HEAD/CYLINDER/PISTON

Loosen the screw and disconnect the radiator joint hose.

Remove the bolts and swing the left radiator forward (page 5-5).

Disconnect the alternator 4P connector.

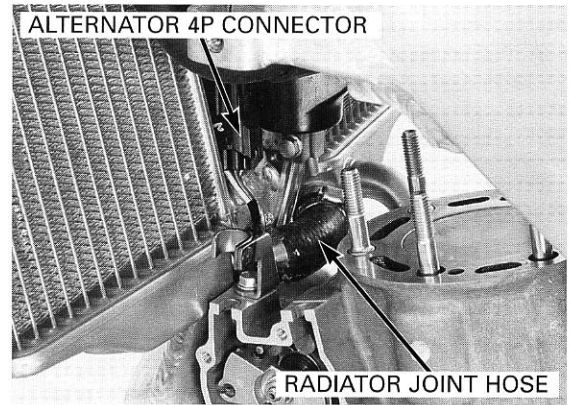

Loosen the cylinder nuts in a crisscross pattern in two or three steps.  
Remove the cylinder.

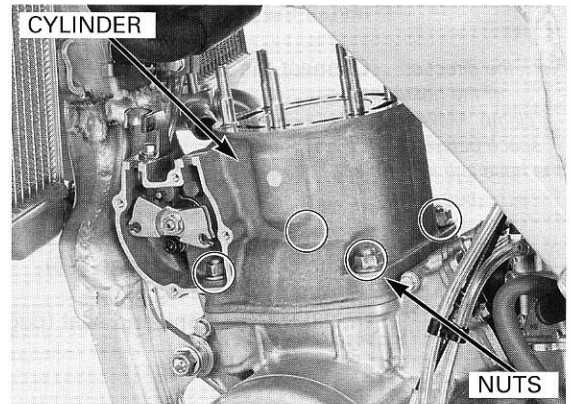

Remove the gasket and dowel pins.

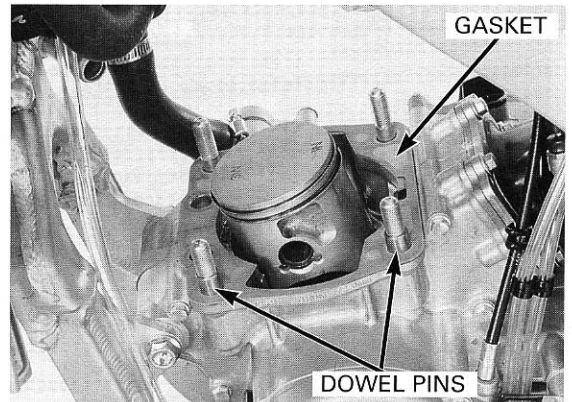

### PISTON REMOVAL

*Do not let the clips fall into the crankcase.*

Remove the piston pin clips.  
Always support the piston when pressing out the pin.  
Remove the piston.

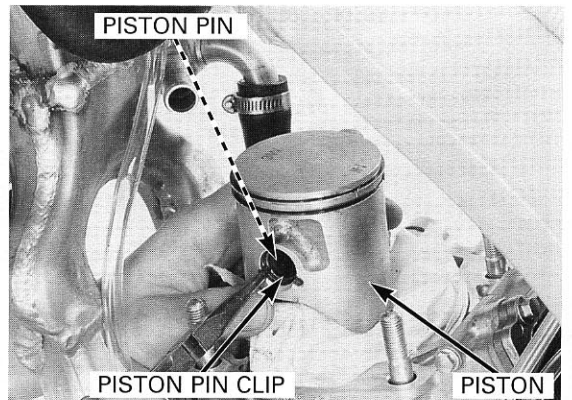

Under racing conditions, the piston and piston rings should be replaced according to the maintenance schedule. See page 3-3.

*Do not damage the piston rings by spreading the ends too far.*

Spread the piston rings and remove them by lifting up at a point just opposite the gap.

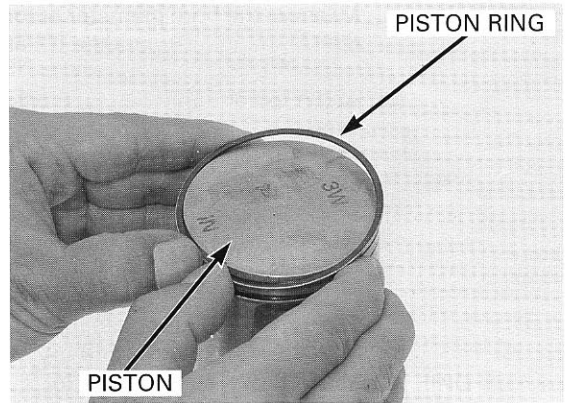

### CYLINDER INSPECTION

Remove the RC valve from the cylinder (section 8).

*Do not damage the cylinder bore.*

Remove the bolt and RC valve cable guide.

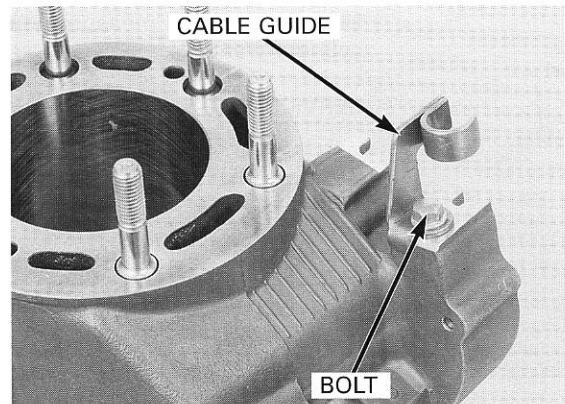

Remove the carbon deposits from the exhaust port area.

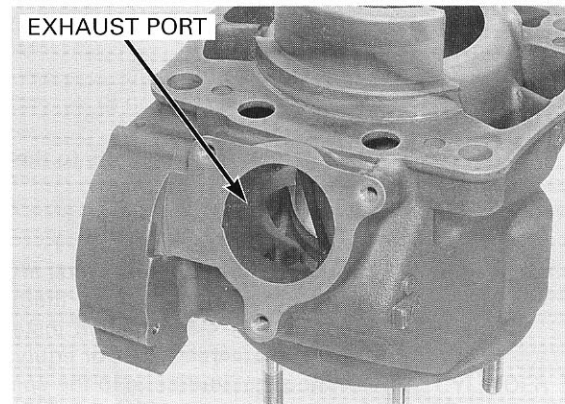

Inspect the top of the cylinder for warpage.

Use a straight edge and feeler gauge to check the head gasket surface on the cylinder for warpage.

If warpage is beyond the service limit, correct as necessary.

**SERVICE LIMIT: 0.05 mm (0.002 in)**

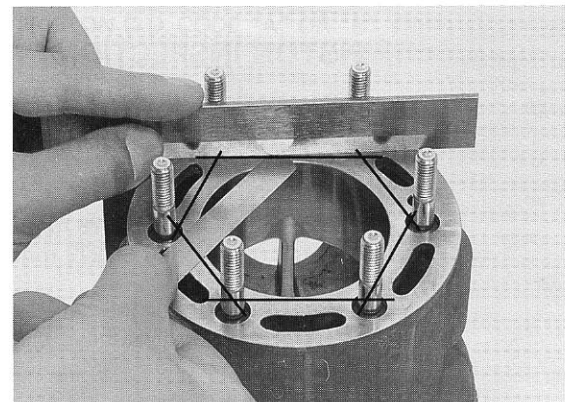

## CYLINDER HEAD/CYLINDER/PISTON

Measure the bore diameter at four positions, top, middle (A), middle (B), middle (C) and bottom.

At the top and middle (A), measure both "X" and "Y" axes.

At the middle (B) and middle (C), measure the "Y" axis.

At the bottom, measure the "X" axis.

The following are the measuring points from the top of the cylinder.

**TOP:** 5 mm (0.20 in)  
**MIDDLE (A):** 30 mm (1.18 in)  
**MIDDLE (B):** 90 mm (3.54 in)  
**BOTTOM:** 120 mm (4.72 in)

Use the largest measurement to determine the cylinder wear.

**SERVICE LIMITS:** A: 66.430 mm (2.615 in)  
B: 66.428 mm (2.615 in)

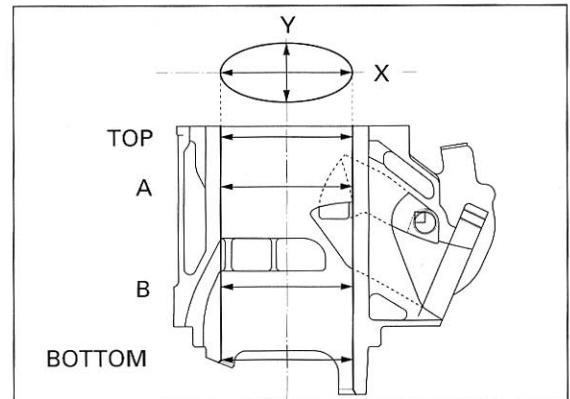
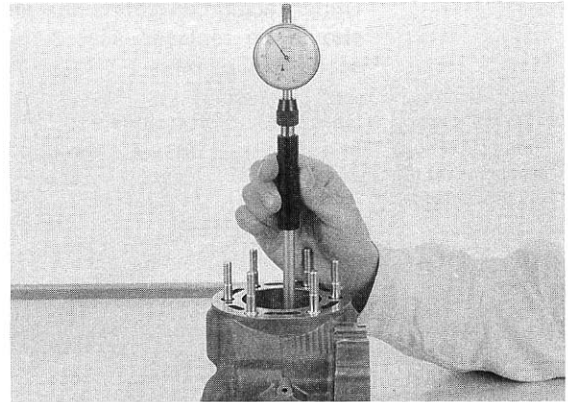

If the cylinder is replaced, remove the following parts from the cylinder.

- Cylinder stud bolts
- RC VALVE (section 8)

Install the following parts to the new cylinder.

- RC VALVE (section 8)
- Cylinder stud bolts

Check that the cylinder studs are tight.

If any are loose, remove them, clean their threads with contact cleaner, then install them using Honda Anaerobic Thread Lock or equivalent.

Tighten the stud bolts to the specified torque.

**TORQUE:** 12 N·m (1.2 kgf·m, 9 lbf·ft)

### PISTON INSPECTION

Measure the piston O.D. 15 – 25 mm (0.59 – 0.98 in) from the bottom of the skirt and at a right angle to the piston pin hole.

**SERVICE LIMITS:** A: 66.28 mm (2.609 in)  
B: 66.273 mm (2.609 in)

If the O.D. is under the service limit or if nearly 7.5 hours of running time have elapsed, replace the piston with a new one.

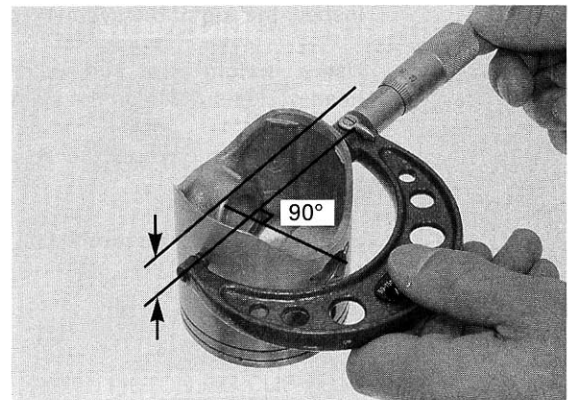
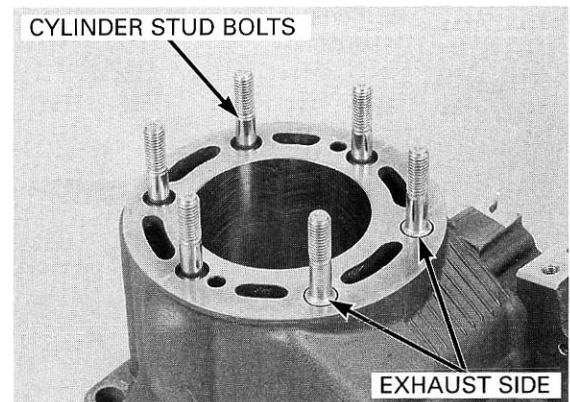

Calculate the cylinder-to-piston clearance.

**SERVICE LIMIT: 0.09 mm (0.004 in)**

Remove the carbon deposits from the the piston ring grooves.

Measure the piston ring-to-groove clearance.

**SERVICE LIMITS: Top: 0.095 mm (0.0037 in)  
Second: 0.075 mm (0.0029 in)**

Measure the piston pin bore I.D.

**SERVICE LIMIT: 18.02 mm (0.709 in)**

Check the piston pin for wear and excessive discoloration.

Measure the piston pin O.D.

**SERVICE LIMIT: 17.98 mm (0.707 in)**

If the O.D. is under the service limit, discolored, or nearly 22.5 hours of running time have elapsed, replace the piston pin and bearing.

Calculate the piston pin-to-piston clearance.

**SERVICE LIMIT: 0.02 mm (0.001 in)**

Insert each piston ring into the cylinder to a distance from the cylinder bottom as shown.

Use the piston to push the ring squarely into the cylinder.

Measure the piston ring end gaps with the feeler gauge.

**SERVICE LIMITS: Top/Second: 0.65 mm (0.026 in)**

### CYLINDER/PISTON SELECTION

The cylinders and pistons are select fitted.

Record the piston O.D. code letter (A or B).

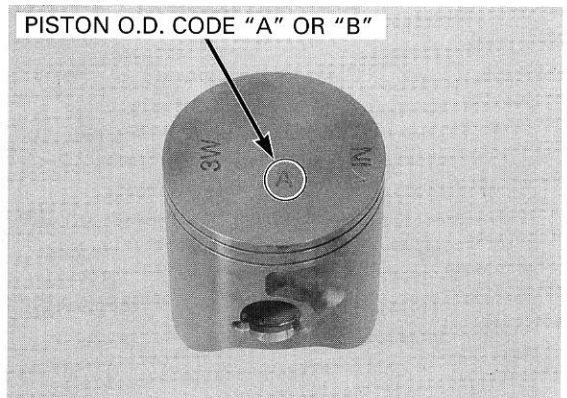
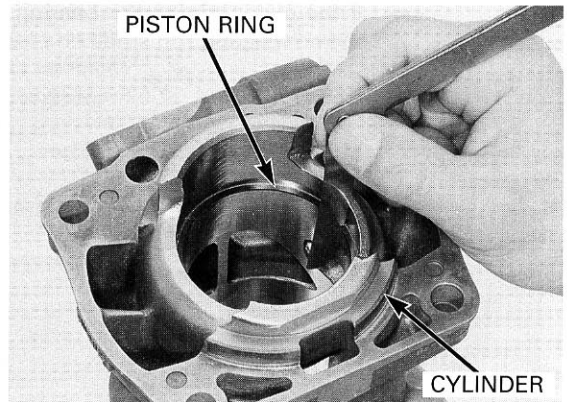
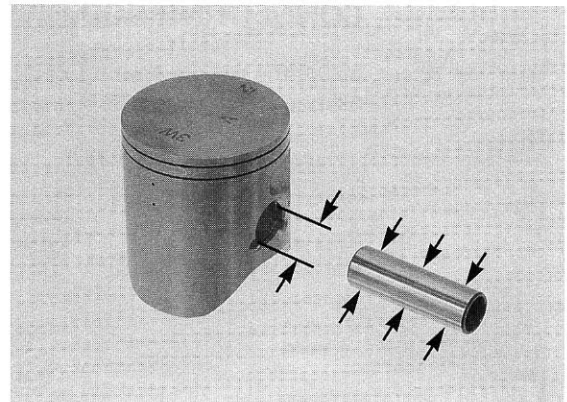
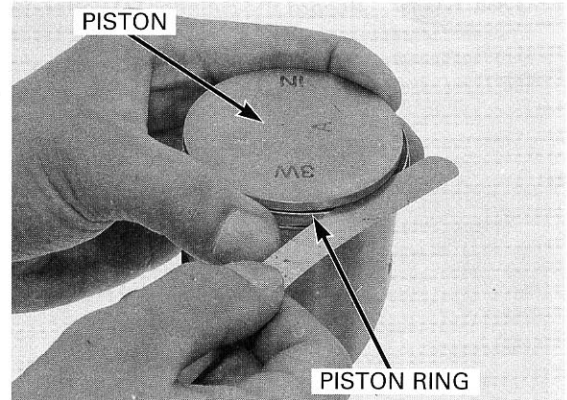

## CYLINDER HEAD/CYLINDER/PISTON

*The new cylinder comes furnished with flap valves and a flap valve shaft.*

Record the cylinder I.D. letter code (A or B).

Use new cylinders and pistons with the same I.D. and O.D. codes when replacing the cylinder and/or piston.

		Cylinder I.D. code	
		A	B
Piston O.D. code	A	O	X
	B	X	O

O: Can be used  
X: Cannot be used

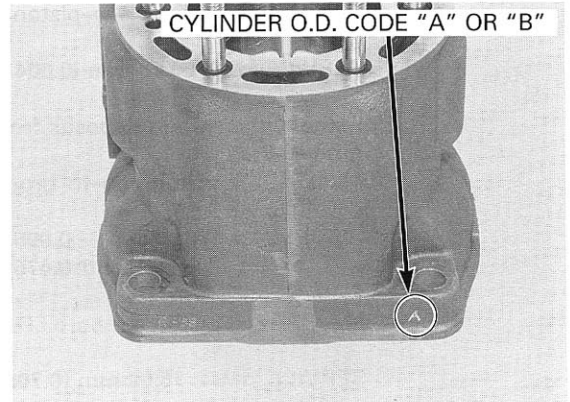

### CONNECTING ROD INSPECTION

Install the needle bearing and piston pin in the connecting rod small end and check it for excessive play.

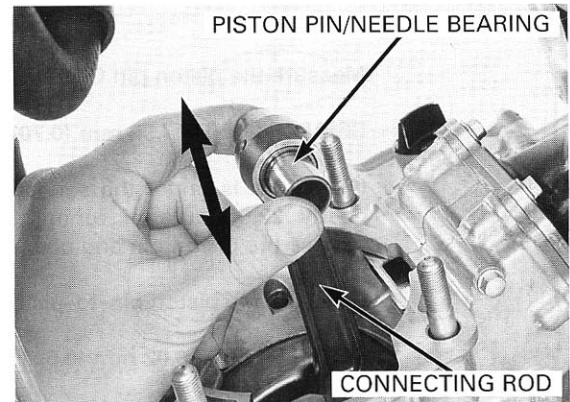

If the piston pin and/or bearing feels loose, measure the connecting rod small end I.D.

**SERVICE LIMIT: 22.02 mm (0.867 in)**

If the I.D. is over the service limit, replace the piston pin and bearing.

If the I.D. is not over the service limit, replace the crankshaft (page 10-8).

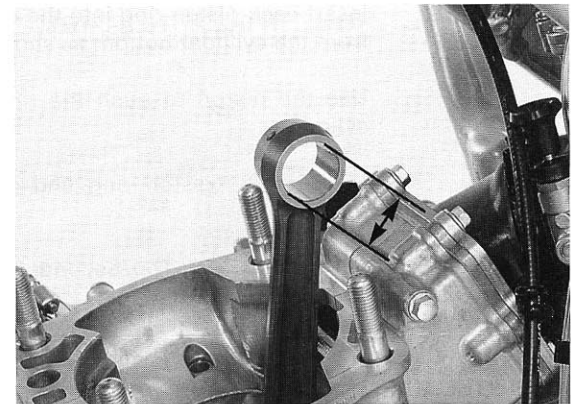

### PISTON INSTALLATION

Clean the piston ring grooves.

Lubricate the piston rings and piston ring grooves with clean Pro Honda HP2 2-stroke oil.

Install the piston rings on the piston with the "IT" marks facing up.

Locate the ring end gaps on the pins in the piston ring grooves.

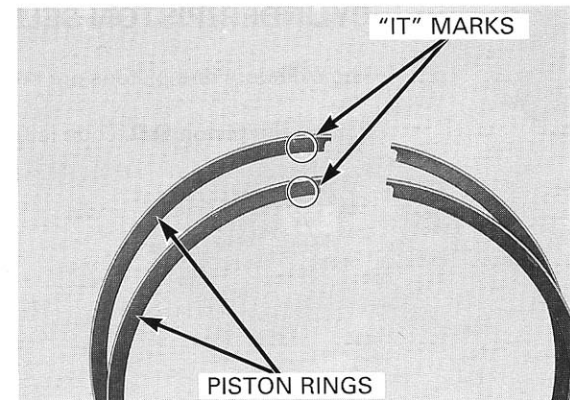

*Be careful not to damage the gasket surface.*

Clean off any gasket material from the cylinder surface.

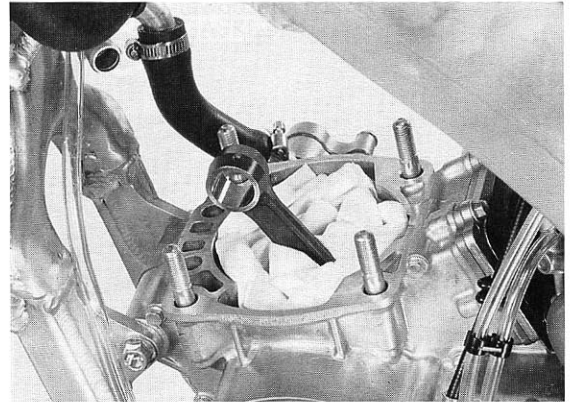

Lubricate the small end bearing and piston pin with clean Pro Honda HP2 2-stroke engine oil.

Install the connecting rod small end bearing.

Install the piston with the "IN" mark facing the intake side. If the "IN" mark is not visible, install the piston with the piston pin clip cut-out facing the intake side.

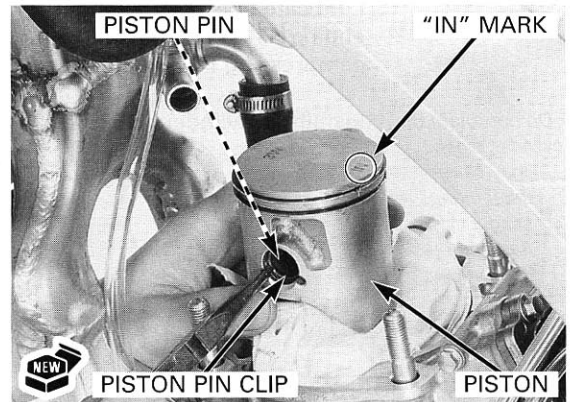

*Use new piston pin clips. Never reuse old clips. Do not let the piston pin clips fall into the crankcase.*

Install the new piston pin clips in the groove in the piston.

Do not align the piston pin clip end gap with the piston pin clip cut-out.

### CYLINDER INSTALLATION

Install the RC valve cable guide and tighten the bolt securely.

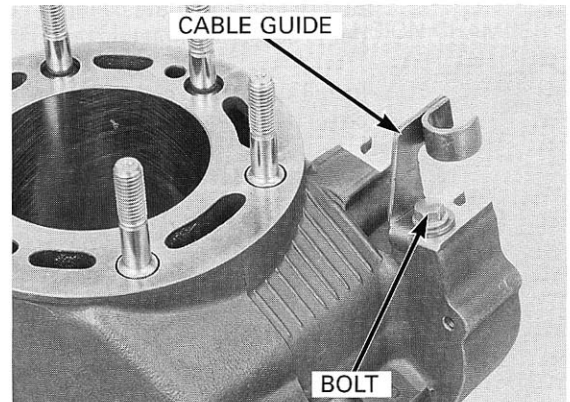

Align the ring end gaps with the piston ring pins.

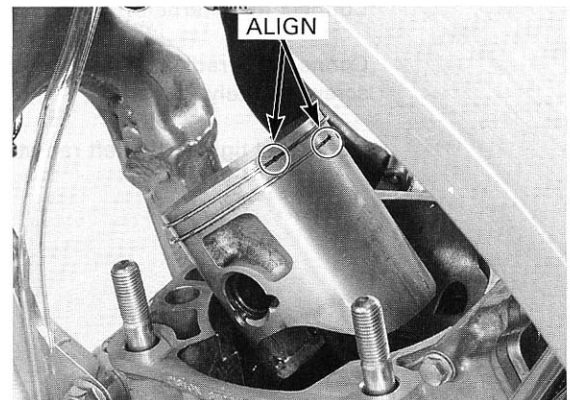



## CYLINDER HEAD/CYLINDER/PISTON

Place the dowel pins and new base gasket on the crankcase.

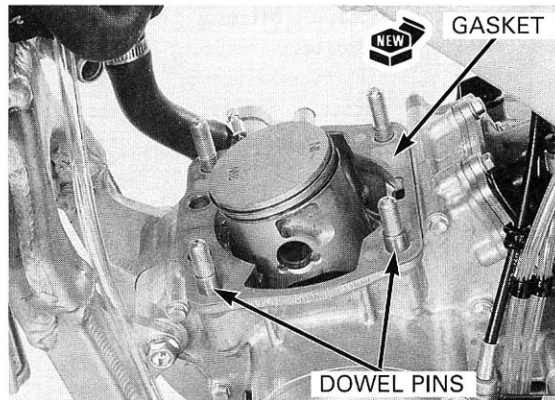

Lubricate the piston with Pro Honda HP2 2-stroke engine oil and slip the cylinder over the piston while compressing the piston rings.

*Do not rotate the cylinder, since this may cause the piston rings to snag a cylinder port and break.*

Install the cylinder onto the crankcase.

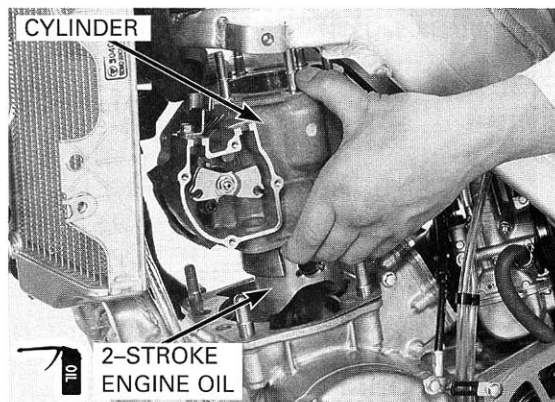

Before tightening the cylinder nuts, be sure the cylinder is seated completely against the crankcase.

Install and tighten the four cylinder nuts in a criss-cross pattern in two or three steps.

**TORQUE: 39 N·m (4.0 kgf·m, 29 lbf·ft)**

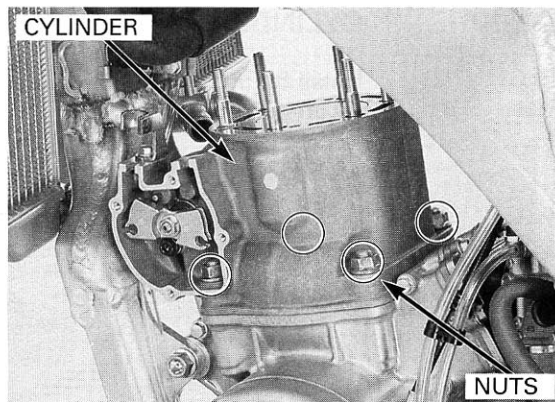

Connect the alternator 4P connector.

Connect the radiator joint hose and tighten the band screw securely.

Install and tighten the left radiator bolts (page 5-6).

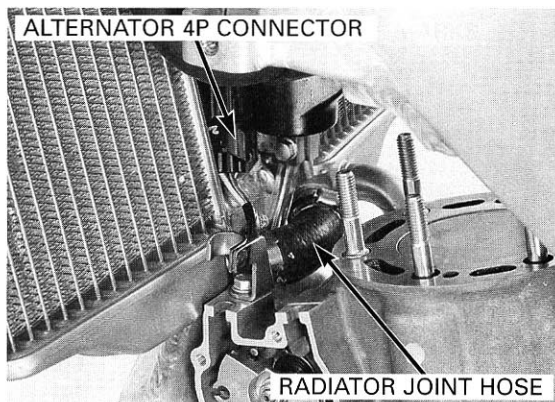

Install the new gasket.

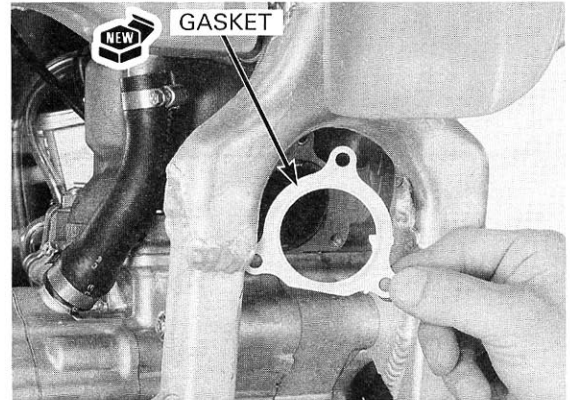

Apply grease to the new O-ring and install it to the exhaust pipe joint groove. Install the exhaust pipe joint as shown and tighten the bolts to the specified torque.

**TORQUE: 12 N·m (1.2 kgf·m, 9 lbf·ft)**

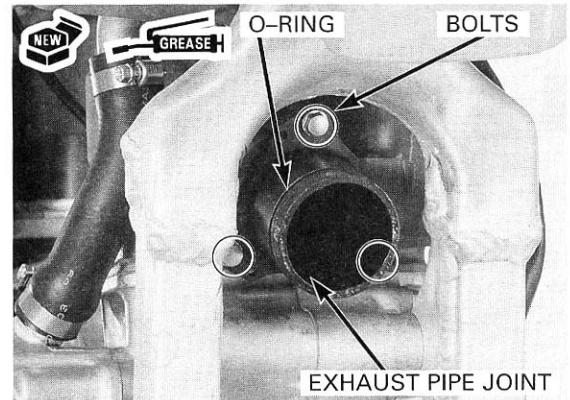

Connect and adjust the RC valve control cables (page 8-9).

Install the expansion chamber (page 2-6).

Install the cylinder head (page 7-4).

Pour the recommended coolant mixture into the radiator to the correct level (page 5-5).

Check for following:

- Compression leaks
- Abnormal engine noise
- Secondary air leak
- Coolant leaks

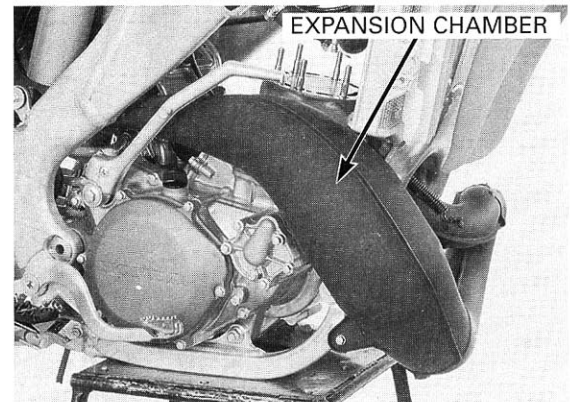

# RC VALVE

---

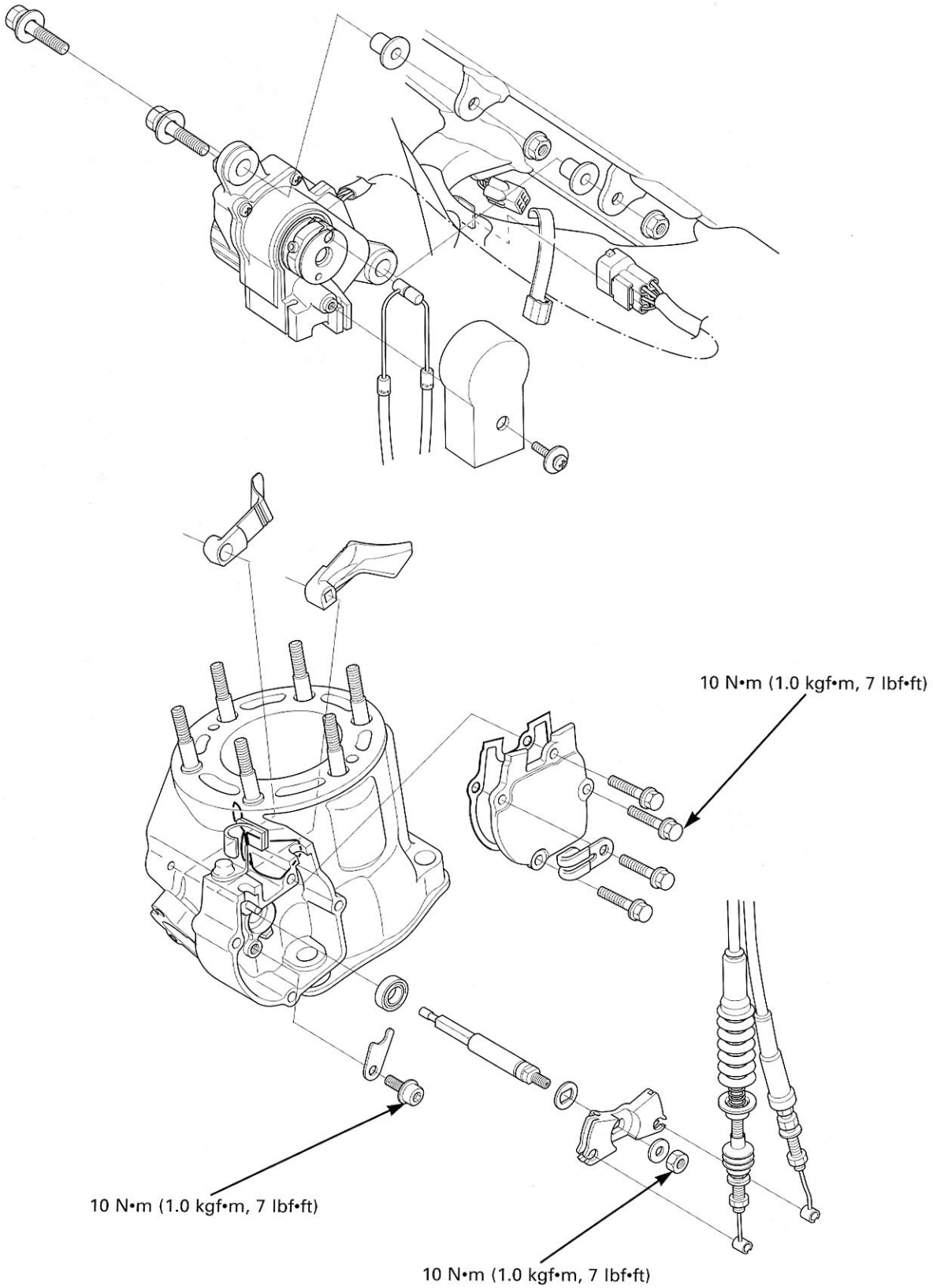

# 8. RC VALVE

SERVICE INFORMATION	8-1	SERVO MOTOR	8-7
TROUBLESHOOTING	8-2	RC VALVE CABLE	8-9
EXHAUST VALVE	8-3		

## SERVICE INFORMATION

### GENERAL

- This section covers the maintenance of the RC valve.
- Decarbonize the flap valves and valve shaft every 2.5 hours of operation (each race).
- If the flap valves or flap valve shaft is worn or damaged, replace the flap valve shaft and flap valves as an assembly.
- If the flap valves are replaced, record the flap valve code letter (B, C, D, E, F or no mark) and select the same code letter ('02 only).

### TORQUE VALUES

Flap valve shaft nut	10 N•m (1.0 kgf•m, 7 lbf•ft)
RC valve shaft stopper socket bolt	10 N•m (1.0 kgf•m, 7 lbf•ft)
RC valve cover bolt	10 N•m (1.0 kgf•m, 7 lbf•ft)

# TROUBLESHOOTING

## Poor performance at low speed

- Exhaust valve does not close fully
  - Incorrect RC valve cable adjustment
  - Faulty servo motor
  - Bent flap valve shaft
- Excessive carbon build-up on the flap valves
- Damaged flap valve

## Poor performance at high speed

- Exhaust valve does not open fully
  - Incorrect RC valve cable adjustment
  - Improper installation
  - Faulty servo motor
- Excessive carbon build-up on the flap valves and valve shaft
- Damaged flap valves

## Engine starts, but does not operate RC valve

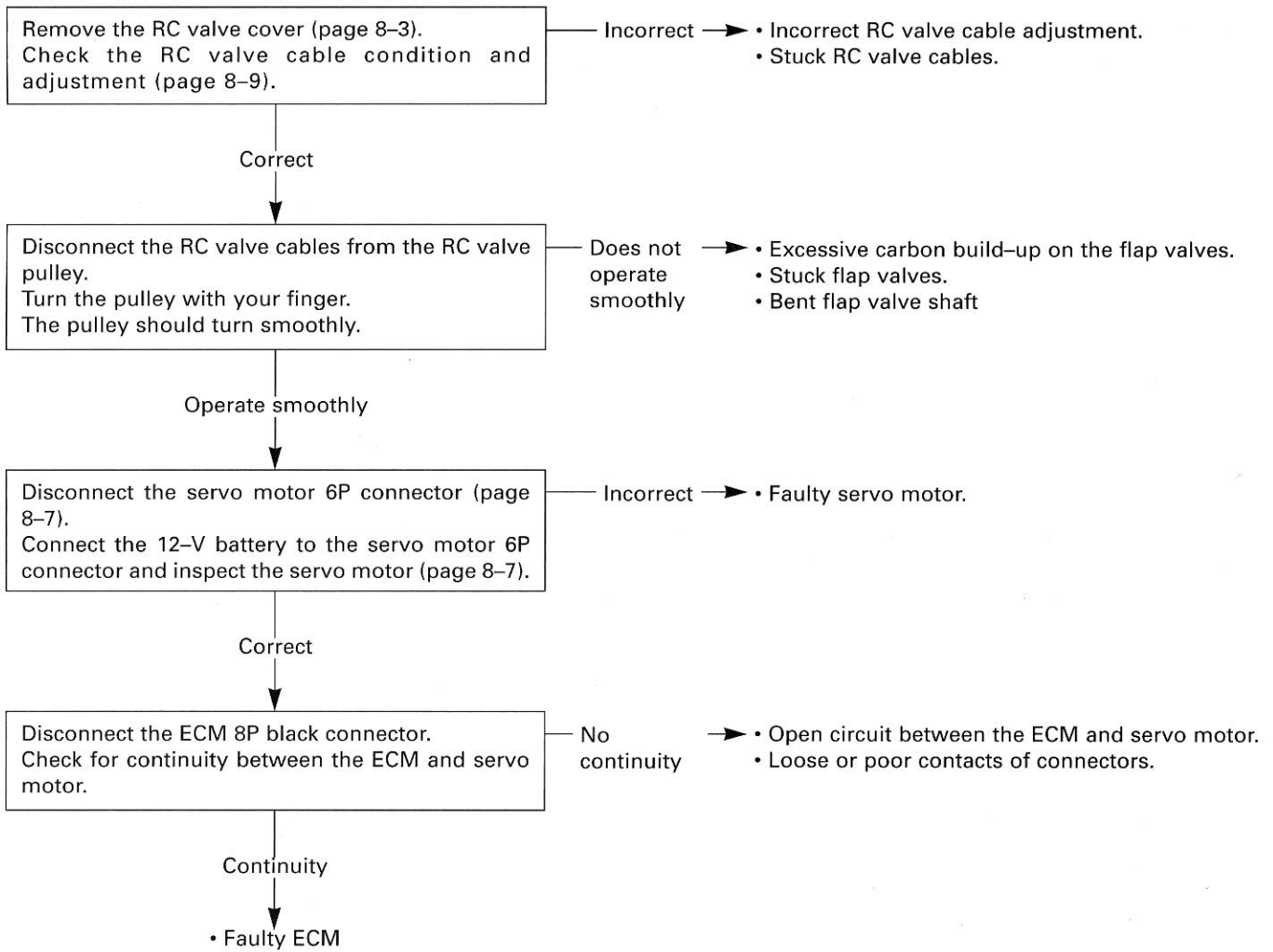

## EXHAUST VALVE

### OPERATING INSPECTION

Warm up the engine to operating temperature.

Stop the engine.

Remove the bolts, wire clamp, RC valve cover and gasket.

Connect the tachometer.

Start the engine and check that the RC valve pulley is in the fully-closed position.

Increase the engine speed to approximately 8,000 rpm and check that the RC valve pulley turns to the fully-open position.

If the exhaust valve does not operate properly, check the following.

Remove the dust covers.

Loosen the lock nuts and disconnect the RC valve cables from the RC valve pulley.

Turn the RC valve pulley with your finger. The RC valve pulley should turn smoothly.

If the RC valve pulley does not turn smoothly, check the following:

- Carbon deposits on the flap valves.
- Stuck flap valves.
- Bent flap valve shaft.

If the RC valve pulley turns smoothly, check the following:

- Incorrect RC valve cable adjustment.
- Stuck RC valve cables.
- Faulty servo motor.

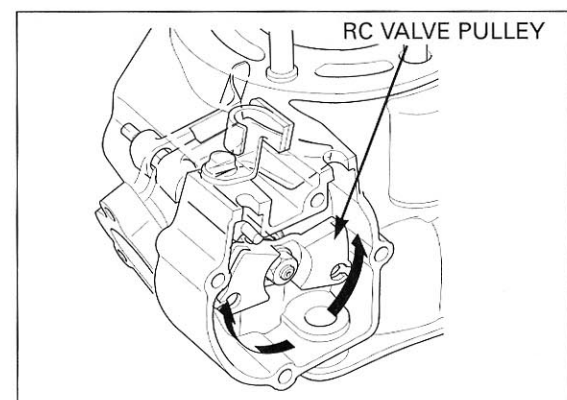
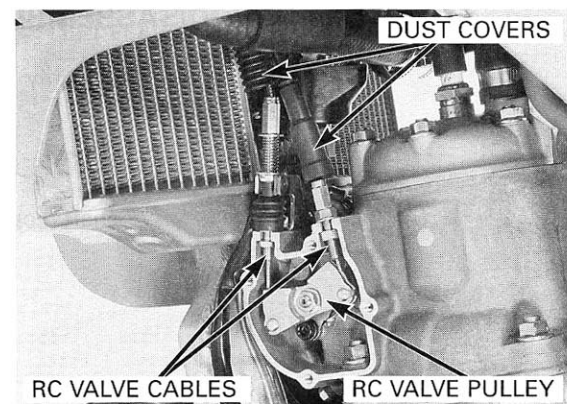
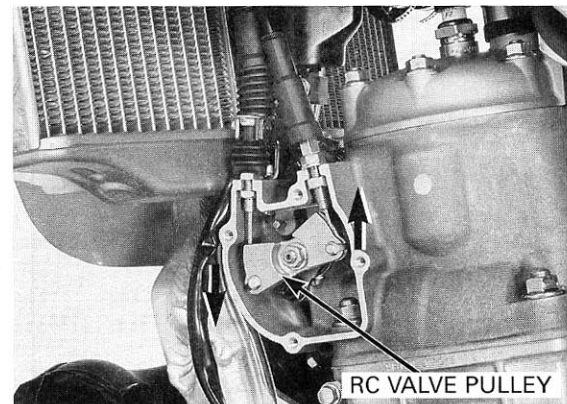
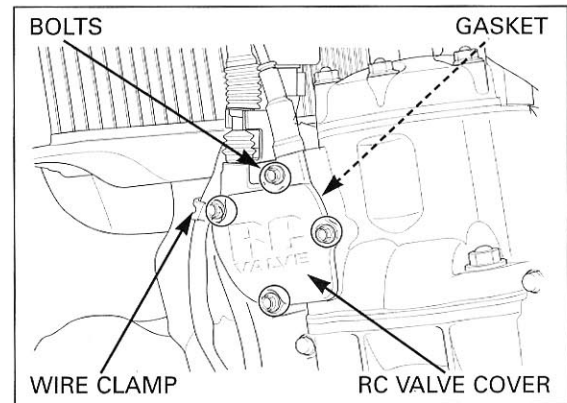

## RC VALVE

Connect the RC valve cables to the RC valve pulley (page 8-9).

Install the new gasket.

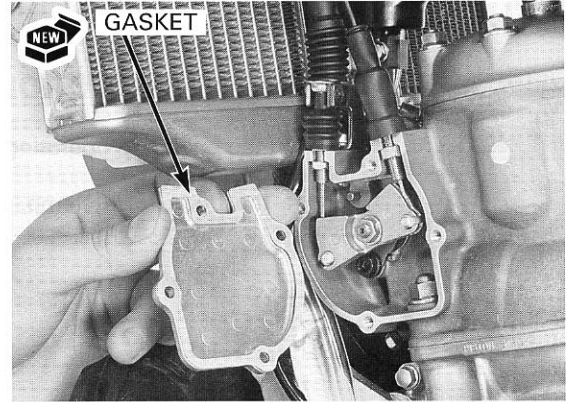

Install the RC valve cover, wire clamp and bolts. Tighten the bolts to the specified torque.

**TORQUE: 10 N·m (1.0 kgf·m, 7 lbf·ft)**

Install the alternator wire to the wire clamp.

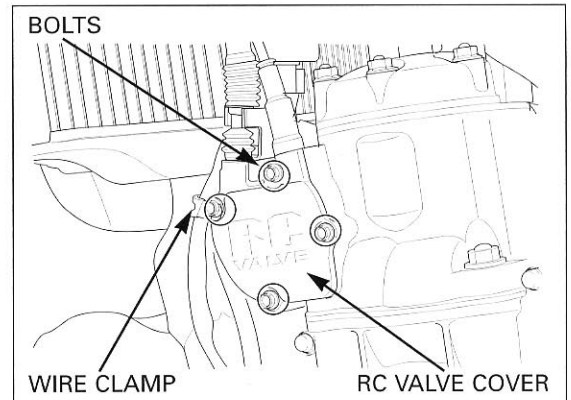

## REMOVAL/DISASSEMBLY

Clean the engine thoroughly to keep dirt from entering the engine.

Remove the cylinder (page 7-5).

Remove the flap valve shaft stopper socket bolt and stopper plate.

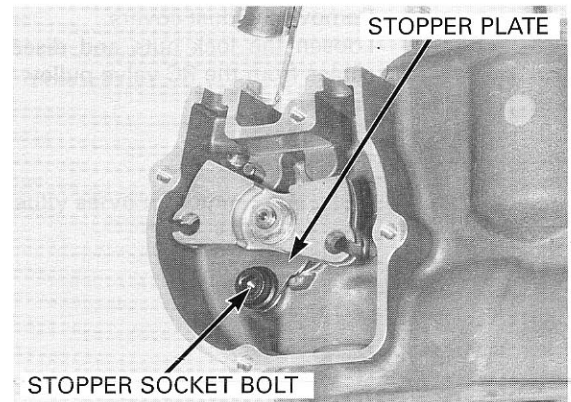

Remove the flap valve shaft assembly, right flap valve and left flap valve from the cylinder.

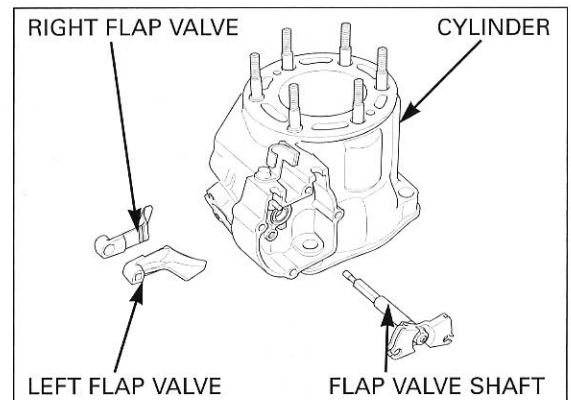

Remove the nut, washer, RC valve pulley and special washer from the flap valve shaft.

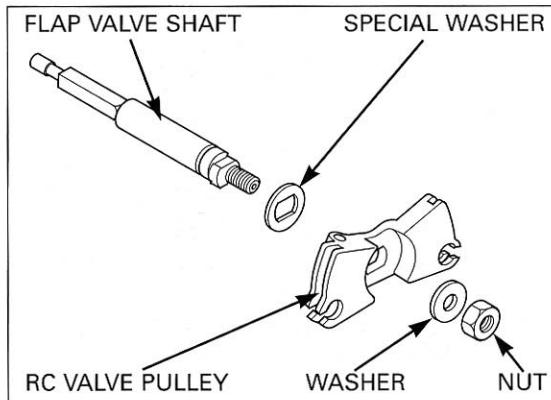

**DECARBONIZING/INSPECTION**

**'02:**  
Remove the carbon deposits from the flap valves. Inspect the flap valves for wear or damage.

*Decarbonize the races of each flap valve.*

*Replace the flap valves and flap valve shaft as a set.*

Replace the flap valves if necessary.  
Record the flap valve code letter (B, C, D, E, F or no mark).  
Select new flap valves with the same code letter when replacing the flap valves.

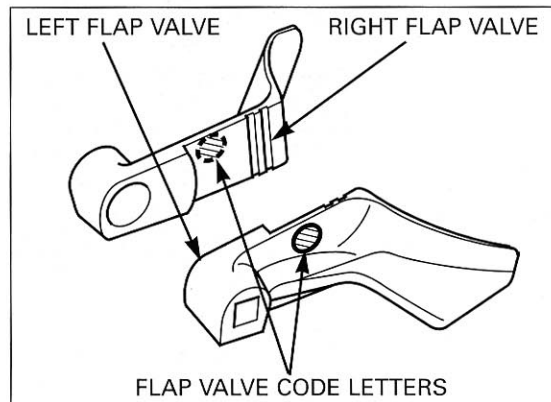

**After '02:**  
Remove the carbon deposits from the flap valves. Inspect the flap valves for wear or damage.

*Decarbonize the races of each flap valve.*

*Replace the flap valves and flap valve shaft as a set.*

Replace the flap valves if necessary.

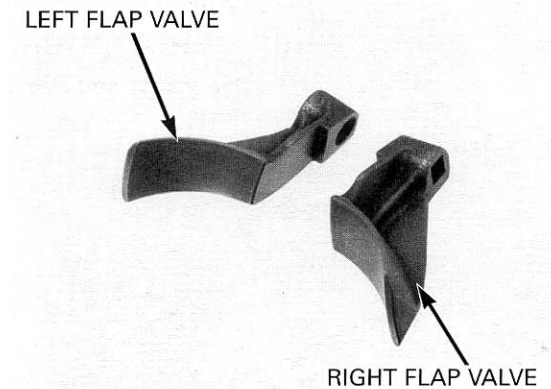

Remove the carbon deposits from the flap valve shaft. Inspect the flap valve drive shaft for wear or damage.

*Decarbonize the races of each flap valve.*

*Replace the flap valves and flap valve shaft as a set.*

Replace the flap valve shaft if necessary.

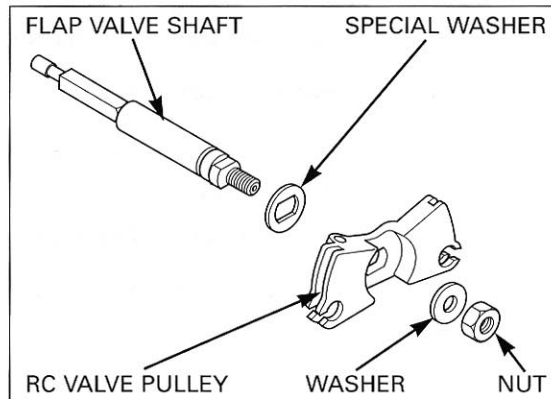



## RC VALVE

Inspect the oil seal for deterioration or damage.

*Be careful not to damage the cylinder when replacing the oil seal.*

Replace the oil seal if necessary.

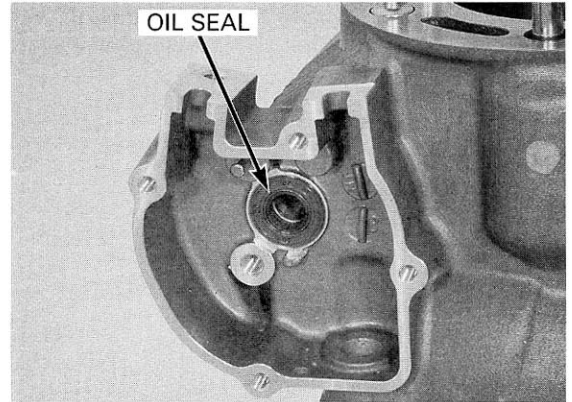

### ASSEMBLY/INSTALLATION

Install the special washer to the flap valve shaft, aligning the cut-outs.  
Install the RC valve pulley to the flap valve shaft, aligning the cut-outs.  
Install the washer and nut to the flap valve shaft and tighten the nut temporarily.

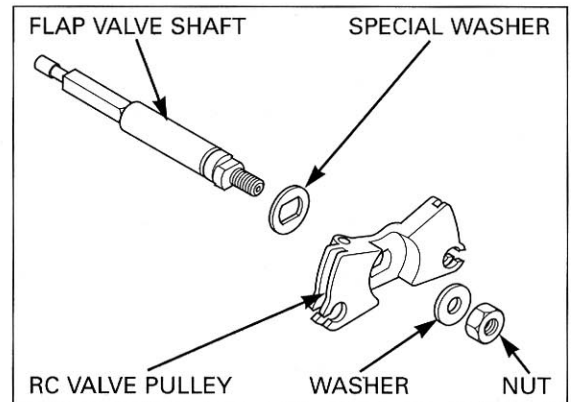

Apply engine oil to the drive shaft sliding and rolling surface.

Install the flap valves and flap valve shaft assembly into the cylinder.

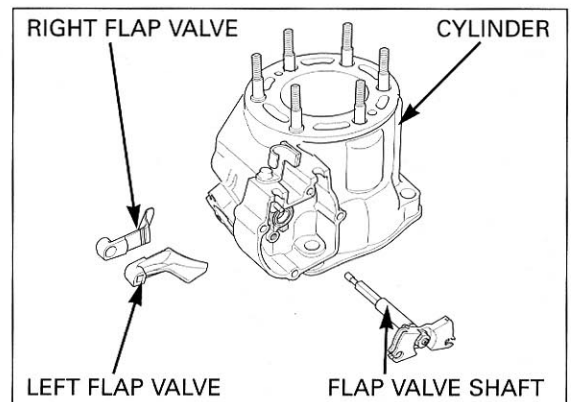

Install the stopper plate and tighten the flap valve shaft stopper plate socket bolt to the specified torque.

**TORQUE: 10 N·m (1.0 kgf·m, 7 lbf·ft)**

Tighten the flap valve shaft nut to the specified torque.

**TORQUE: 10 N·m (1.0 kgf·m, 7 lbf·ft)**

Install the cylinder (page 7-11).

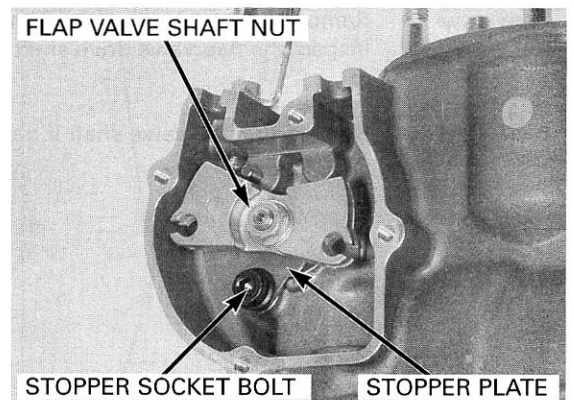

## SERVO MOTOR

### INSPECTION

Remove the fuel tank (page 2-5).  
Disconnect the RC valve cables from the RC valve pulley (page 8-3).

Remove the screw and servo motor cover.

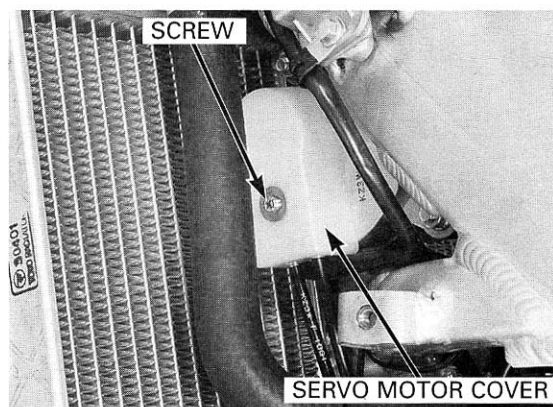

Disconnect the RC valve cables from the servo motor.

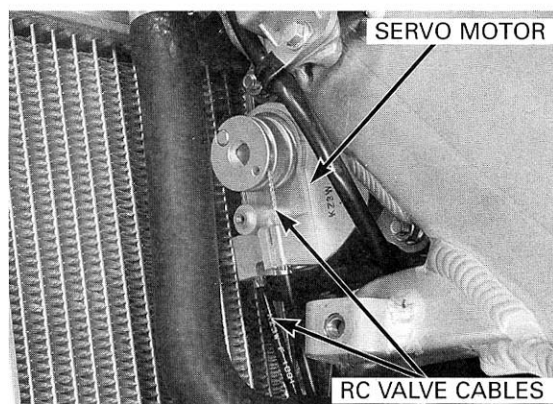

Remove the wire band.  
Disconnect the servo motor 6P connector.

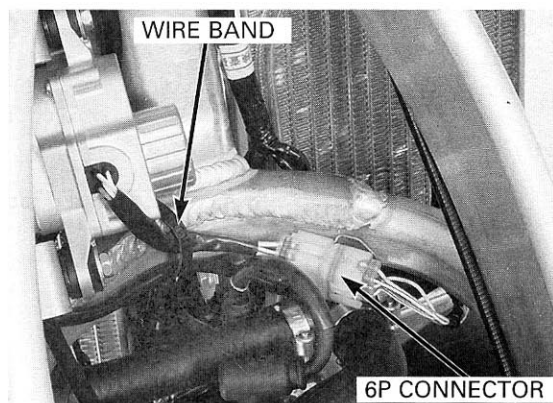

### MOTOR INSPECTION

*Be careful not to short the battery terminals.*

Connect the 12-V battery to the servo motor side 6P connector.  
Check that the servo motor pulley turns counterclockwise.

**CONNECTION: White/black (+) — White/green (-)**

Then, switch the 12-V battery connection.  
Check that the servo motor pulley turns clockwise.

**CONNECTION: White/green (+) — White/black (-)**

Replace the servo motor if the servo motor operation is abnormal.

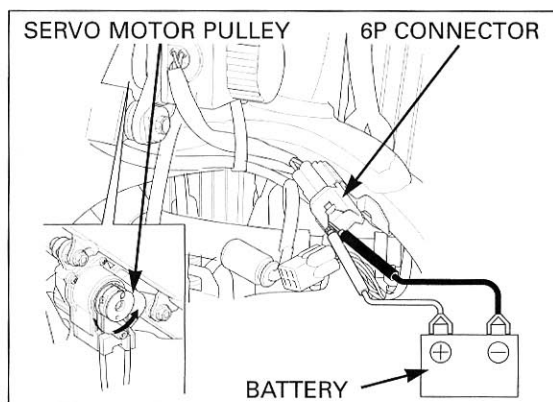

## RC VALVE

### RESISTANCE INSPECTION

Measure the resistance at the servo motor side 6P connector.

**CONNECTION:** Yellow/red — Blue/green  
**RESISTANCE:** 3.5 – 6.5 k $\Omega$  (20 °C/68 °F)

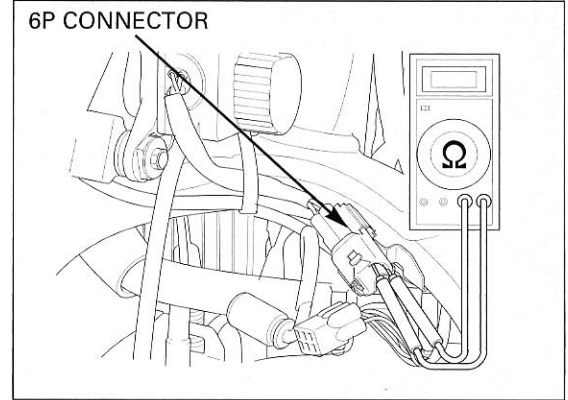

*Be careful not to short the battery terminals.*

Connect the 12-V battery to the servo motor side 6P connector.

Measure the resistance at the servo motor side 6P connector using the analogue tester.

### BATTERY CONNECTION:

White/black (+) — White/green (-)

### TESTER CONNECTION:

Light green — Blue/green

**RESISTANCE:** Repeat 0 to 3.5 – 6.5 k $\Omega$  (20 °C/68 °F)

Replace the servo motor if the servo motor operation is abnormal.

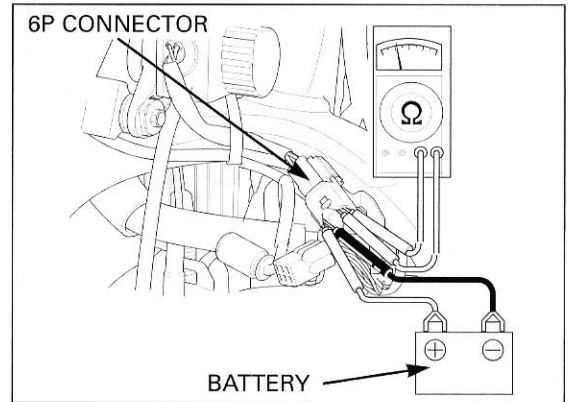

## REMOVAL/INSTALLATION

Remove the fuel tank (page 2-5).  
Disconnect the RC valve cables from the RC valve pulley (page 8-3).

Remove the screw and servo motor cover.

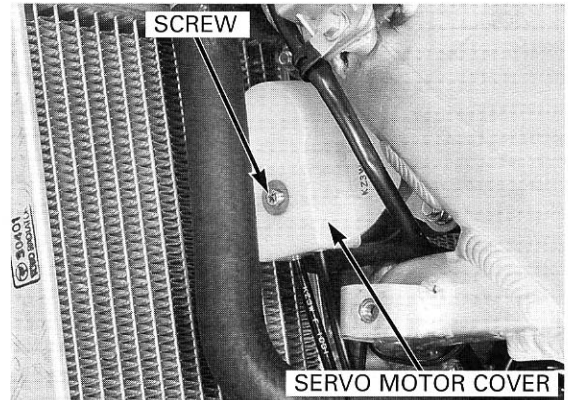

Disconnect the RC valve cables from the servo motor.

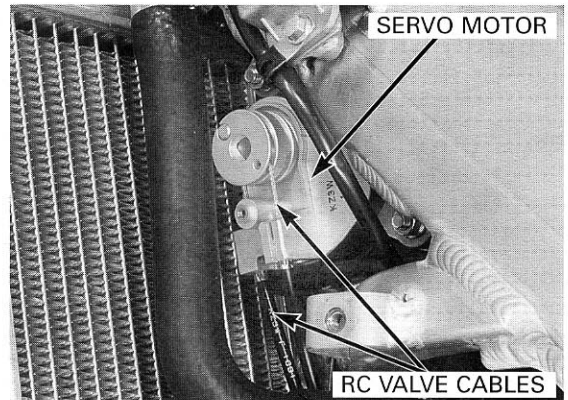

Remove the wire band and disconnect the servo motor 6P connector.

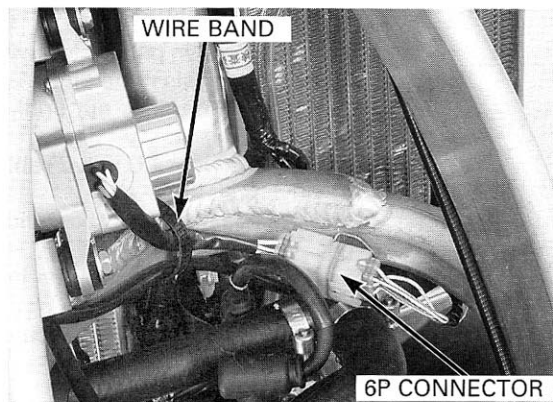

Remove the nuts, bolts and servo motor.

Installation is in the reverse order of removal. Route the RC valve cables properly (page 1-17).

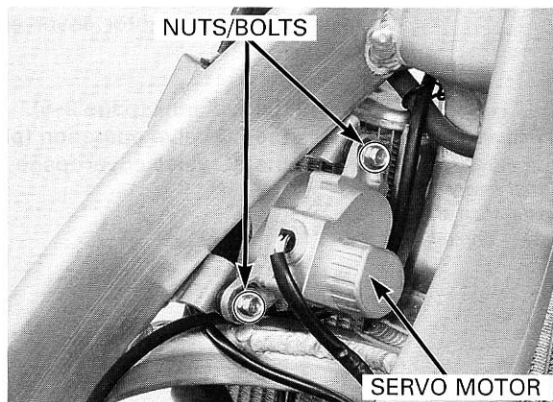

## RC VALVE CABLE

### RC VALVE CABLE CONNECTION/ADJUSTMENT

Cable adjustment is done automatically via the servo motor and spring.

#### SERVO MOTOR SIDE

Connect the rear RC valve cable to the servo motor pulley.

Connect the front RC valve cable (spring/seat) to the servo motor pulley.

Install the RC valve cables to the grooves in the servo motor body.

Route the RC valve cables properly (page 1-17).

#### CYLINDER SIDE (REAR)

Turn the outer lock nut until it seats against the adjuster.

Connect the rear RC valve cable to the RC valve pulley.

Turn the RC valve pulley counterclockwise fully.

Turn the adjuster clockwise until the inner lock nut seats to the cylinder.

Tighten the outer lock nut securely.

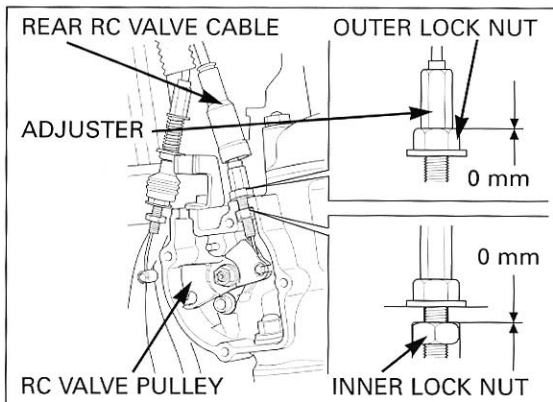
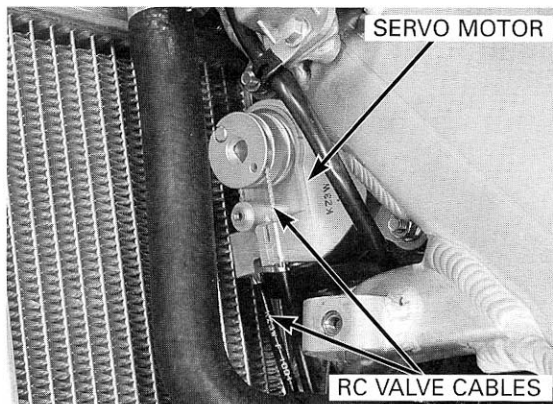

# CLUTCH/KICKSTARTER/GEARSHIFT LINKAGE

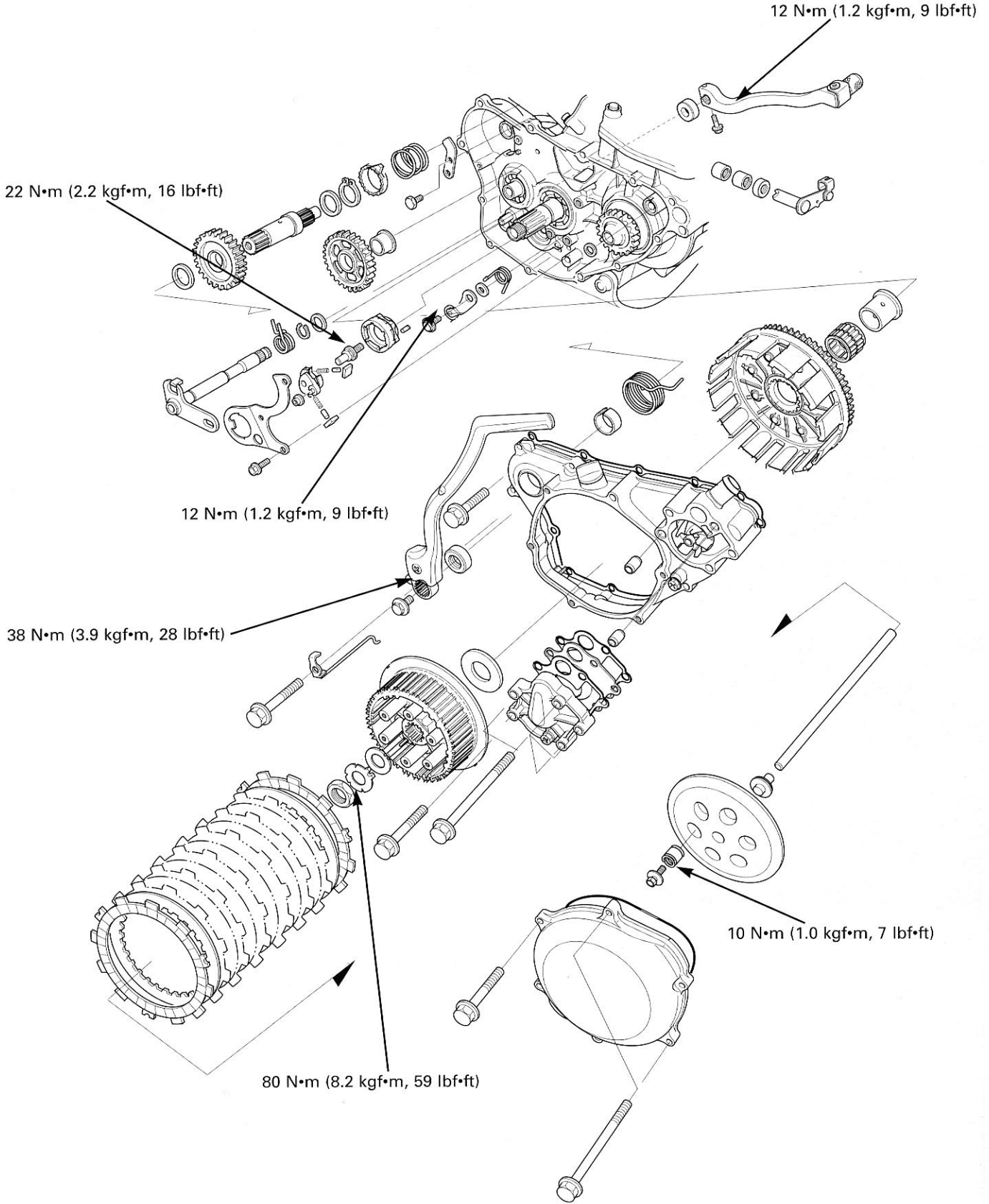

# 9. CLUTCH/KICKSTARTER/GEARSHIFT LINKAGE

<b>SERVICE INFORMATION</b>	<b>9-1</b>	<b>CLUTCH</b>	<b>9-4</b>
<b>TROUBLESHOOTING</b>	<b>9-2</b>	<b>KICKSTARTER</b>	<b>9-12</b>
<b>RIGHT CRANKCASE COVER</b>	<b>9-3</b>	<b>GEARSHIFT LINKAGE</b>	<b>9-15</b>

## SERVICE INFORMATION

### GENERAL

- This section covers service of the clutch, gearshift linkage, shift drum and shift forks. All service can be done with the engine installed in the frame.
- Transmission oil viscosity and level have an effect on clutch disengagement. Oil additives also affect clutch performance and are not recommended. When the clutch does not disengage or the motorcycle creeps with clutch disengaged, inspect the transmission oil level before servicing the clutch system.

### SPECIFICATIONS

Unit: mm (in)

ITEM		STANDARD	SERVICE LIMIT
Clutch lever free play		10 – 20 (3/8 – 3/4)	—
Clutch spring free length		45.7 (1.83)	44.7 (1.76)
Clutch outer guide O.D.		27.987 – 28.000 (1.1018 – 1.1024)	27.97 (1.101)
Clutch disc thickness		2.92 – 3.08 (0.114 – 0.121)	2.85 (0.112)
Clutch plate warpage		—	0.20 (0.008)
Kickstarter pinion gear I.D.		22.007 – 22.028 (0.8664 – 0.8672)	22.05 (0.868)
Kickstarter spindle O.D.		21.959 – 21.980 (0.8645 – 0.8654)	21.95 (0.864)
Kickstarter idle gear I.D.		20.020 – 20.041 (0.7882 – 0.7890)	20.07 (0.790)
Kickstarter idle gear bushing	I.D.	17.000 – 17.018 (0.6693 – 0.6700)	17.04 (0.671)
	O.D.	19.979 – 20.000 (0.7866 – 0.7874)	19.96 (0.786)
Countershaft I.D. at kickstarter idle gear		16.966 – 16.984 (0.6680 – 0.6687)	16.95 (0.667)

**9**

### TORQUE VALUES

Clutch center lock nut	80 N•m (8.2 kgf•m, 59 lbf•ft)
Clutch spring bolt	10 N•m (10 kgf•m, 7 lbf•ft)
Gearshift drum center pin	22 N•m (2.2 kgf•m, 16 lbf•ft) Apply a locking agent to the threads.
Gearshift drum stopper arm bolt	12 N•m (1.2 kgf•m, 9 lbf•ft)
Kickstarter pedal bolt	38 N•m (3.9 kgf•m, 28 lbf•ft)
Gearshift pedal bolt	12 N•m (1.2 kgf•m, 9 lbf•ft)

### TOOLS

Clutch center holder	07724-0050001 or 07724-0050002 or equivalent commercially available in U.S.A.
----------------------	---

### TROUBLESHOOTING

#### Hard to shift

- Incorrect clutch adjustment
- Loose stopper plate bolt
- Damaged stopper plate and pin
- Damaged gearshift spindle

#### Transmission jumps out of gear

- Worn shift drum stopper arm
- Weak or broken shift arm return spring
- Loose stopper plate bolt

#### Gearshift pedal will not return

- Weak or broken gearshift spindle return spring
- Bent gearshift spindle

#### Clutch slips when accelerating

- Incorrect clutch adjustment
- Worn clutch discs
- Weak clutch springs
- Transmission oil mixed with molybdenum or graphite additive

#### Motorcycle creeps with the engine idling

- Incorrect clutch adjustment
- Clutch plate warped
- Faulty clutch lifter
- Incorrect transmission oil

## RIGHT CRANKCASE COVER

### REMOVAL

Drain the coolant (page 5-5).  
 Drain the transmission oil (page 3-10).  
 Remove the expansion chamber (page 2-6).  
 Remove the brake pedal pivot bolt and move the pedal aside (page 13-21).

Remove the kickstarter pedal bolt and kickstarter pedal.

Remove the bolts and water pump cover (page 5-7).

Loosen the clamp screw and disconnect the radiator hose form the right crankcase cover.

Remove the bolts, hose guide and right crankcase cover.

Remove the gasket and dowel pins.

Check the starter spindle oil seal for deteriorated or damage.

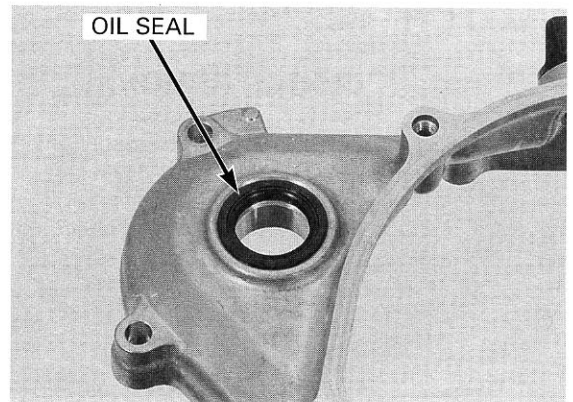
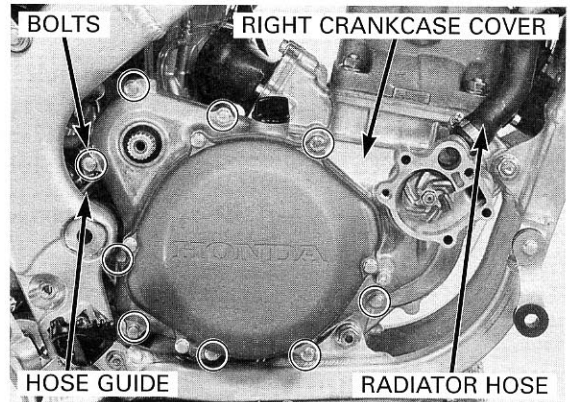
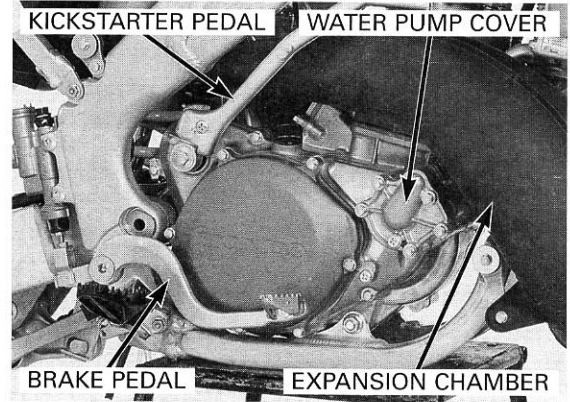

### INSTALLATION

Install the dowel pins and new gasket.

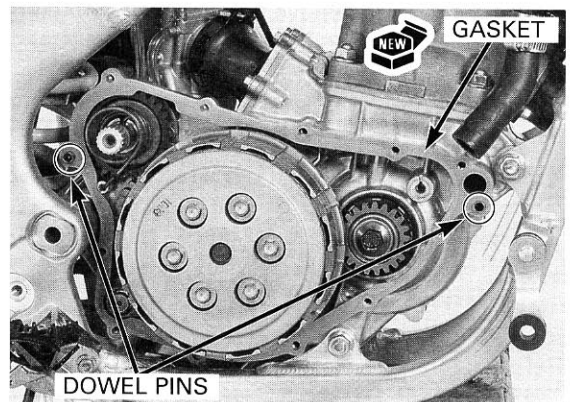



## CLUTCH/KICKSTARTER/GEARSHIFT LINKAGE

Install the right crankcase cover while engaging the water pump gear with the primary drive gear.

Install the hose guide and tighten the bolts securely.

Connect the radiator hose to the right crankcase cover and tighten the clamp screw securely.

Install the water pump cover (page 5-11).

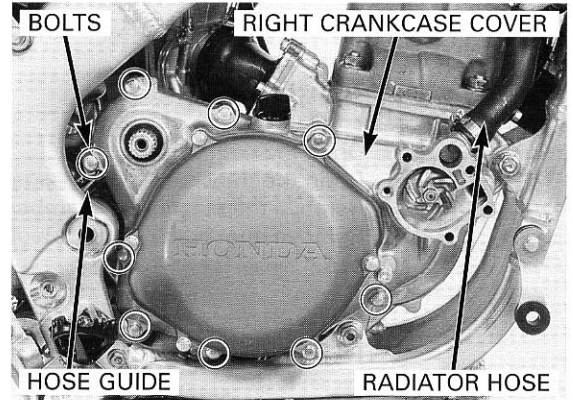

Install the kickstarter pedal and bolt. Tighten the kickstarter pedal bolt to the specified torque.

**TORQUE: 38 N·m (3.9 kgf·m, 28 lbf·ft)**

Install the brake pedal (page 13-21).  
Install the expansion chamber (page 2-6).

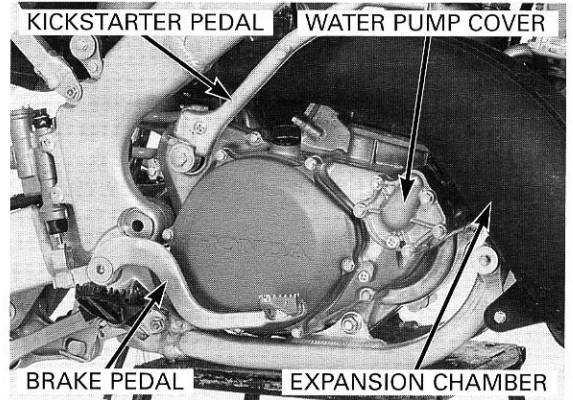

Fill the transmission with the recommended oil to the correct level (page 3-10).  
Pour the radiator coolant mixture into the radiator to the correct level (page 5-5).  
Check and adjust the rear brake pedal height (page 3-15).  
Start the engine and check for oil leaks.

## CLUTCH

### CLUTCH REMOVAL

Remove the brake pedal pivot bolt and move the pedal aside (page 13-21).

Remove the bolts and clutch cover.

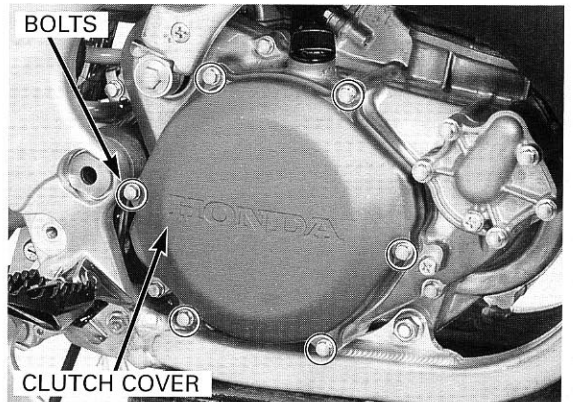

Remove the six clutch spring bolts in a crisscross pattern in two or three steps.  
Remove the clutch springs.

Remove the clutch pressure plate.

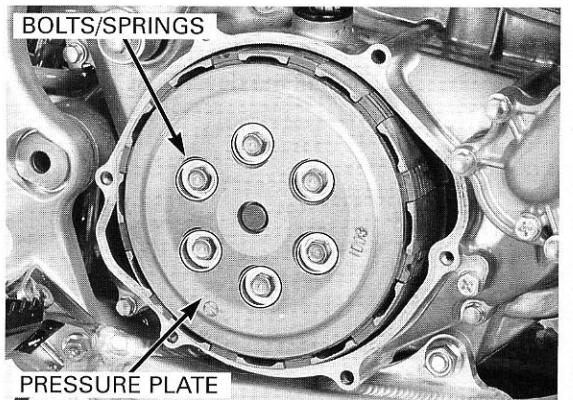

## CLUTCH/KICKSTARTER/GEARSHIFT LINKAGE

Turn the clutch lifter with your finger, check that the clutch lifter needle bearing turns smoothly.

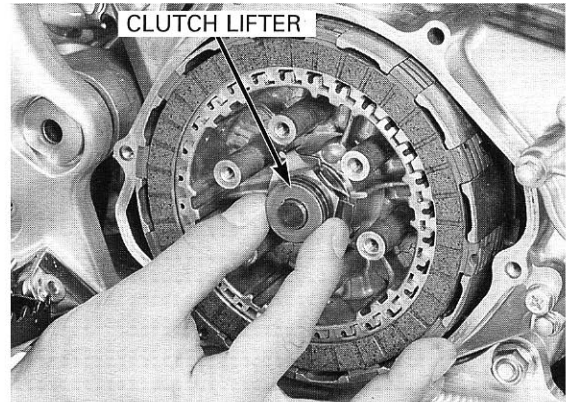

Remove the clutch lifter and lifter rod.

Remove the eight clutch friction discs and seven clutch plates.

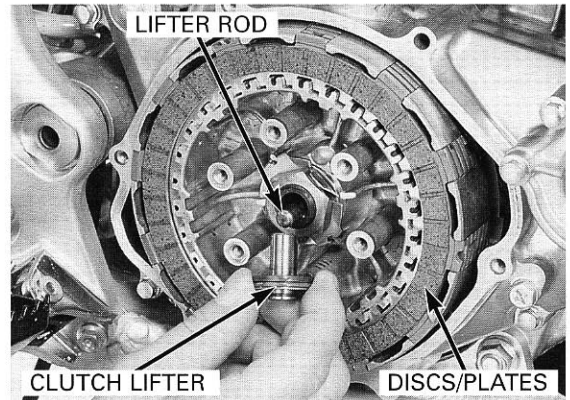

Bend the tabs of the lock washer away from the lock nut.

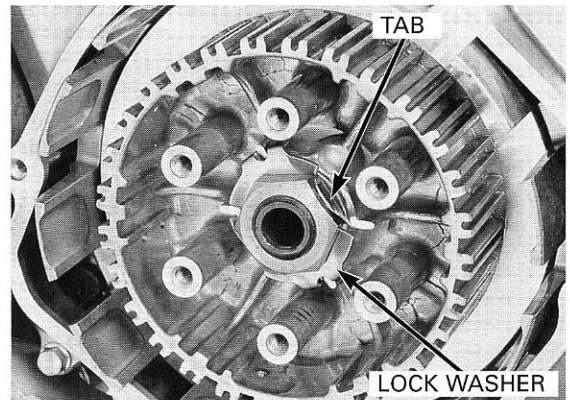

Hold the clutch center with the clutch center holder. Remove the lock nut, lock washer and thrust washer.

**TOOL:**

**Clutch center holder**      07724-0050001 or  
07724-0050002 or  
equivalent commercially  
available in U.S.A.

Remove the tool and clutch center.

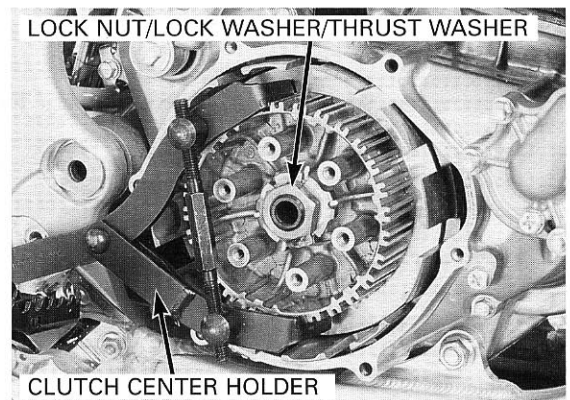

## CLUTCH/KICKSTARTER/GEARSHIFT LINKAGE

Remove the right crankcase cover (page 9-3).

Remove the thrust washer and clutch outer.

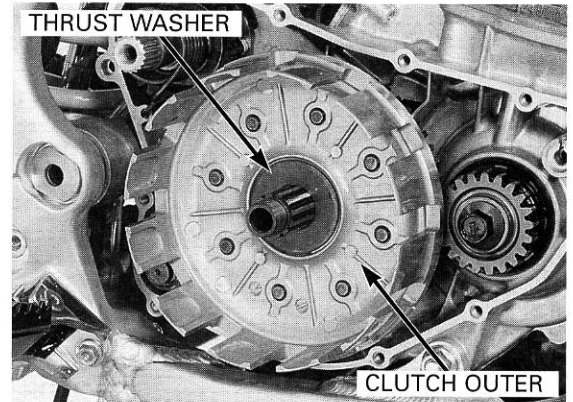

Remove the needle bearing and clutch outer guide.

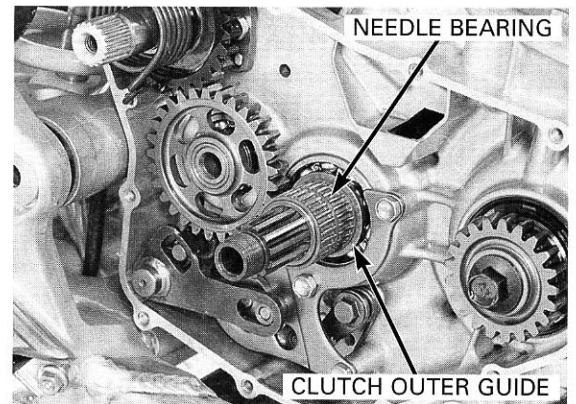

Remove the alternator cover (page 14-8).

Disconnect the clutch cable from the clutch lifter lever by loosening the clutch cable adjuster

Remove the flywheel and stator (page 14-8).

Remove the clutch lifter lever from the left crankcase.

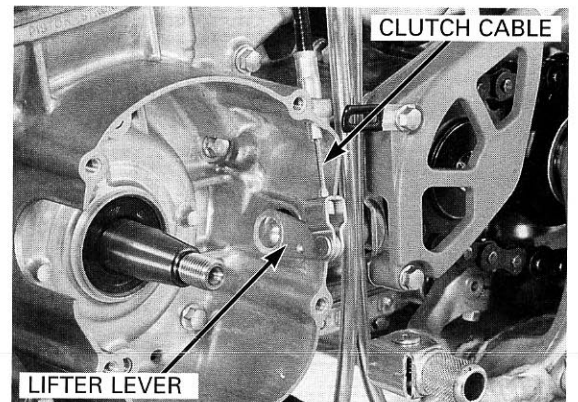

### INSPECTION

#### CLUTCH SPRING

Measure the clutch spring free length.

**SERVICE LIMIT: 44.7 mm (1.76 in)**

*Replace the clutch springs as a set.*

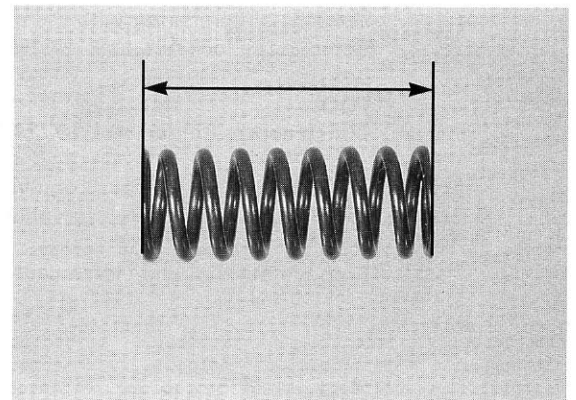

### CLUTCH DISC

Check the clutch discs for signs of scoring or discoloration.

*Replace the clutch discs and plates as a set.*

Measure the thickness of the discs.

**SERVICE LIMIT: 2.85 mm (0.112 in)**

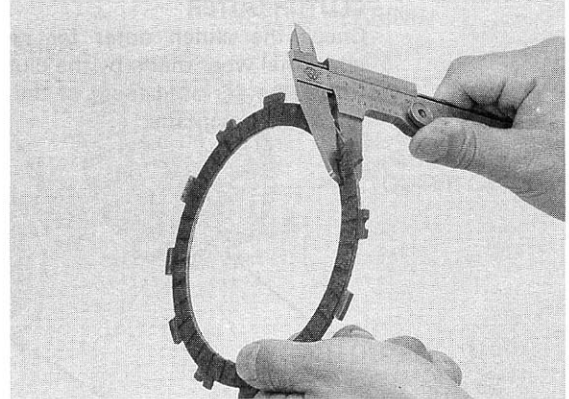

### CLUTCH PLATE

Check the plates for excessive warpage or discoloration. Check the plate warpage on a surface plate using a feeler gauge.

*Replace the clutch discs and plates as a set.*

Measure the warpage of the plates.

**SERVICE LIMIT: 0.20 mm (0.008 in)**

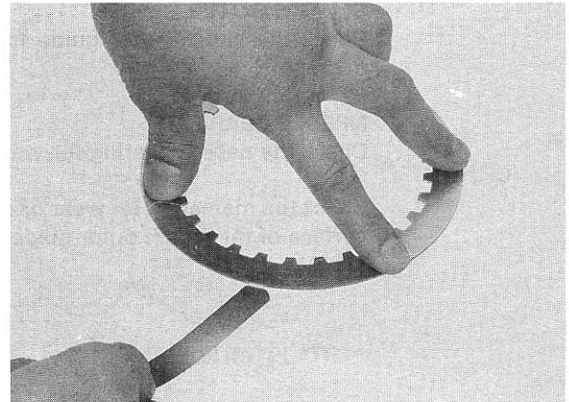

### CLUTCH CENTER

Check the clutch center for nicks, indentations or abnormal wear made by the clutch plates.

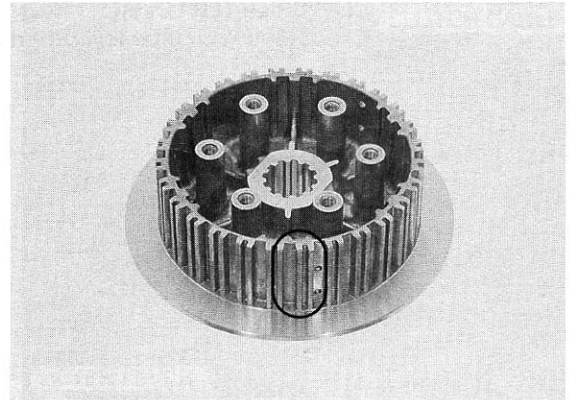

### CLUTCH LIFTER

Check the clutch lifter for wear or damage.

### CLUTCH LIFTER ROD

Check the clutch lifter rod for damage and warpage.

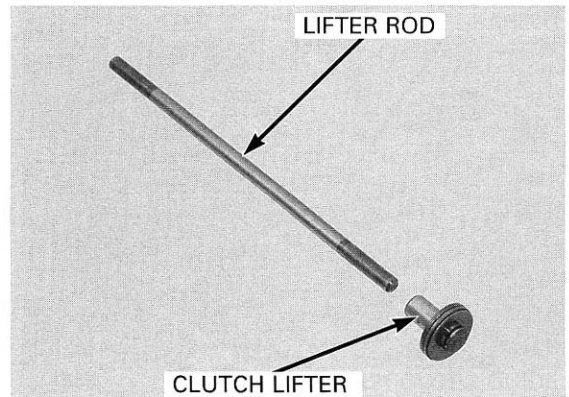

## CLUTCH/KICKSTARTER/GEARSHIFT LINKAGE

### CLUTCH OUTER

Check the clutch outer for nicks, indentations or abnormal wear made by the clutch discs.  
Check the serrated teeth of the primary driven gear for wear or damage.

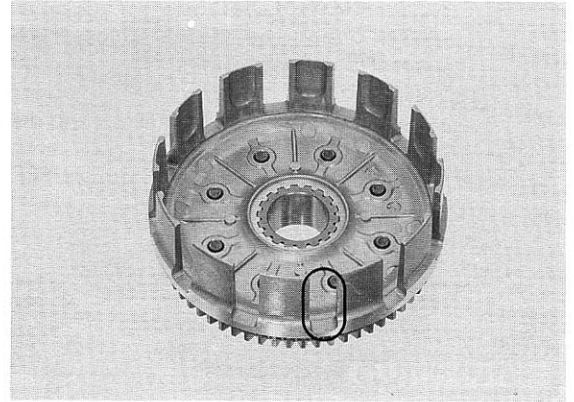

### CLUTCH OUTER GUIDE

Check the clutch outer guide for abnormal wear or damage.

### NEEDLE BEARING

Check the needle bearing for wear or damage.

Check the mainshaft for wear or damage at the sliding surface of the clutch outer guide.

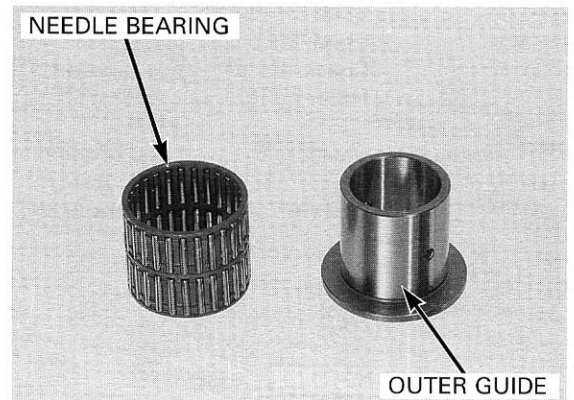

### CLUTCH LIFTER LEVER

Check the clutch lifter lever for damage.

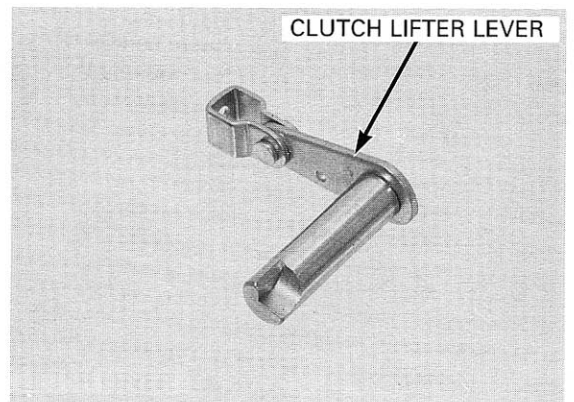

Check the oil seal and needle bearing for wear or damage.

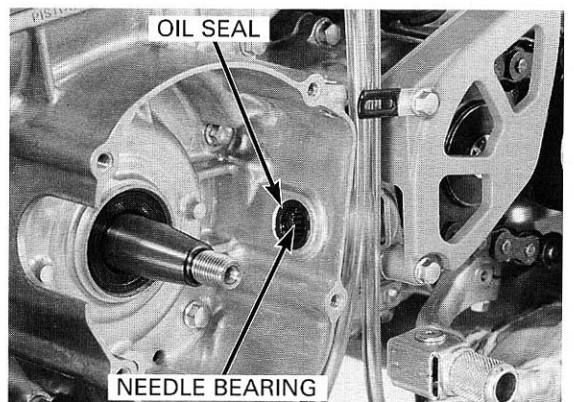

INSTALLATION

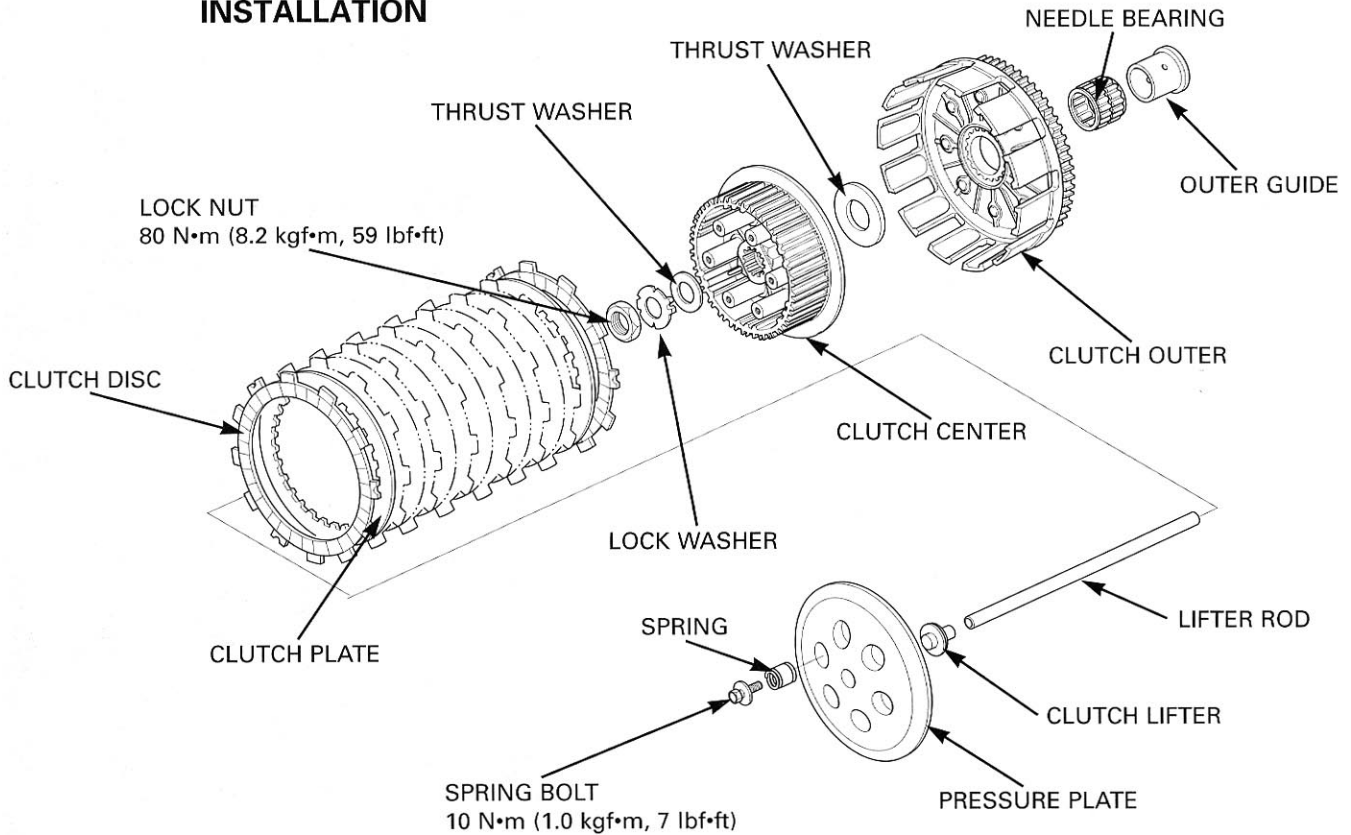

Apply Pro Honda Moly 60 or equivalent molybdenum paste to the clutch lifter lever sliding surface. Install the clutch lifter lever to the crankcase.

Install the stator and flywheel (page 14-9).

Connect the clutch cable to the clutch lifter lever.

After installation, check the following:

- Ignition timing (page 14-9)
- Clutch operation (page 3-15)

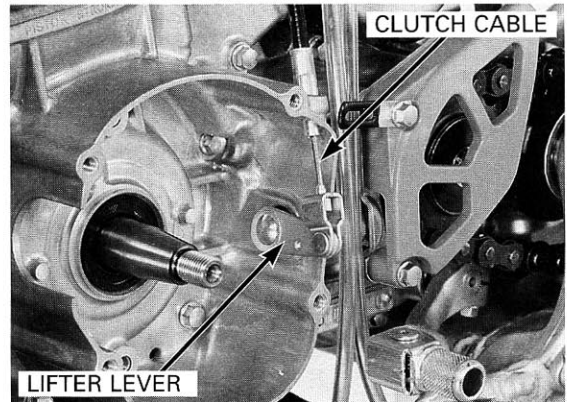

Apply transmission oil to the clutch outer guide and needle bearing. Install the clutch outer guide and needle bearing onto the mainshaft.

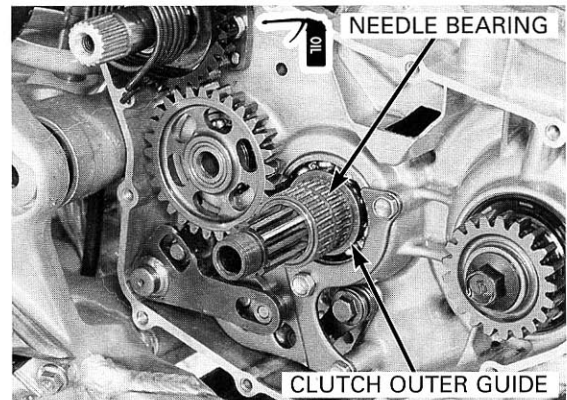

## CLUTCH/KICKSTARTER/GEARSHIFT LINKAGE

Install the clutch outer and thrust washer.

Install the right crankcase cover (page 9-3).

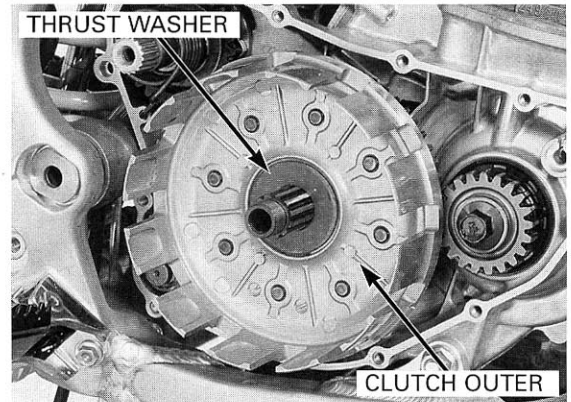

Install the clutch center onto the mainshaft.

Install the thrust washer.

Align the groove in the new lock washer with a rib on the clutch center and slip it into place on the mainshaft.

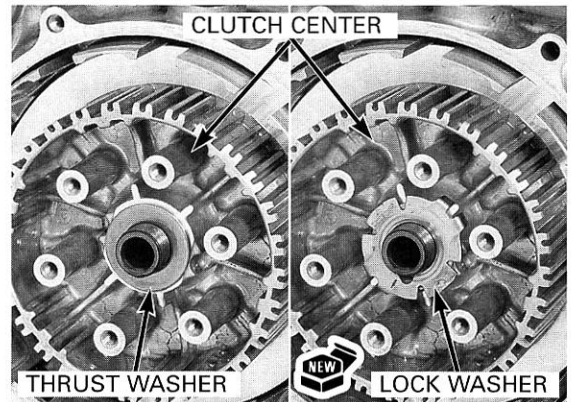

Install the clutch center lock nut and tighten the nut to the specified torque while holding the clutch center with the clutch center holder.

### TOOL:

**Clutch center holder**      07724-0050001 or  
07724-0050002 or  
equivalent commercially  
available in U.S.A.

**TORQUE: 80 N·m (8.2 kgf·m, 59 lbf·ft)**

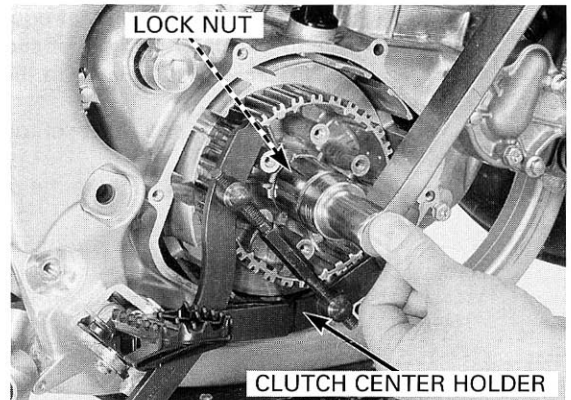

Bend the tabs of the lock washer up against the clutch center nut.

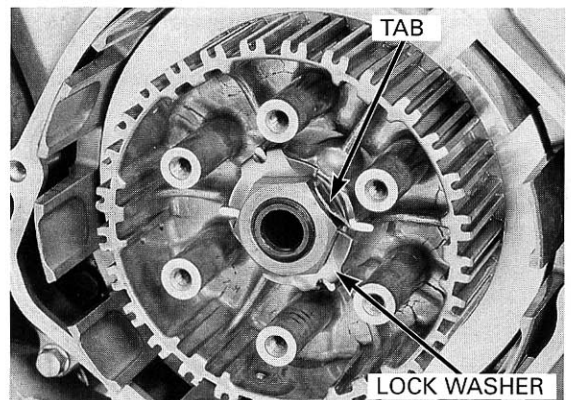

## CLUTCH/KICKSTARTER/GEARSHIFT LINKAGE

Coat the clutch plates and discs with clean transmission oil.

*The outer clutch plate is aluminum.*

Install the eight friction discs and seven clutch plates (five aluminum plates and two steel plates) alternately, starting with a disc.

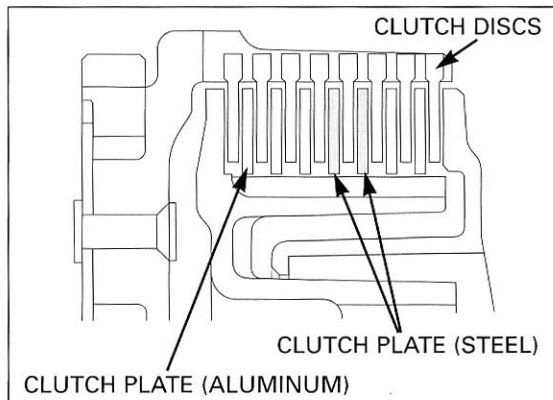

Apply grease to the steel ball and clutch lifter rod.

Insert the clutch lifter rod into the mainshaft.  
Install the clutch lifter.

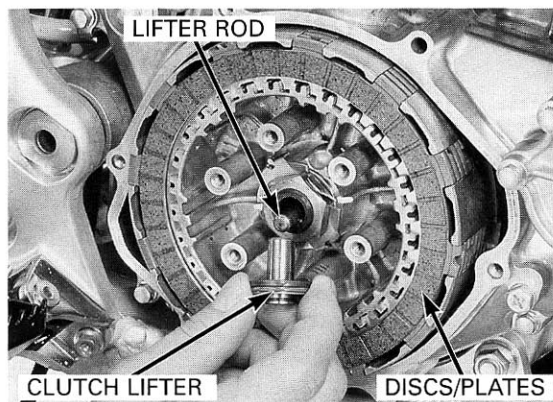

Install the clutch pressure plate.  
Install the six springs and spring bolts.  
Tighten the bolts in a crisscross pattern in two or three steps.

**TORQUE: 10 N•m (1.0 kgf•m, 7 lbf•ft)**

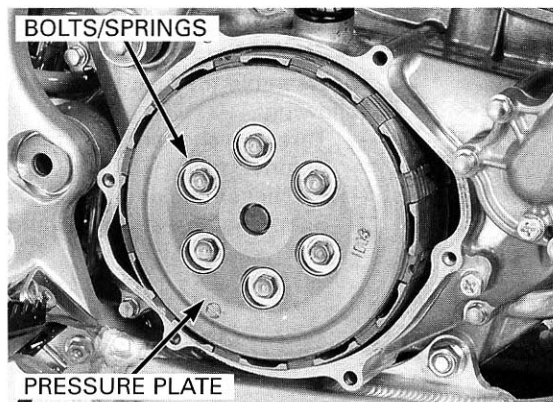

Check that the clutch cover O-ring is in good condition.  
Apply oil to the O-ring and install the clutch cover.

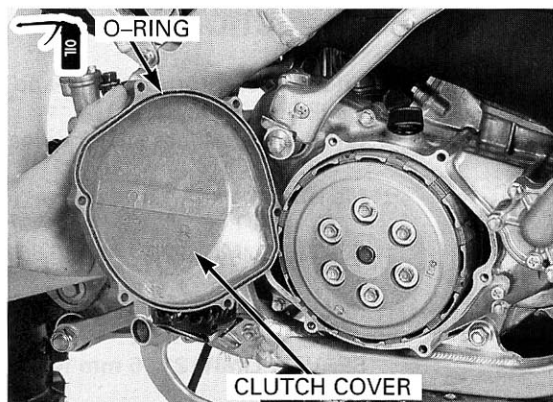



## CLUTCH/KICKSTARTER/GEARSHIFT LINKAGE

Install and tighten the clutch cover bolts securely.

Install the brake pedal (page 13–21).  
Adjust the clutch lever free play (page 3–15).

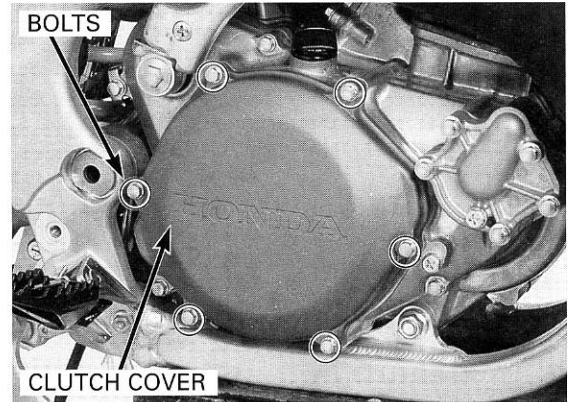

## KICKSTARTER

### REMOVAL

Remove the right crankcase cover (page 9–3).  
Remove the clutch (page 9–4).

Remove the idle gear and bushing.

Unhook the kickstarter return spring from the crankcase, and pull the kickstarter spindle assembly out.

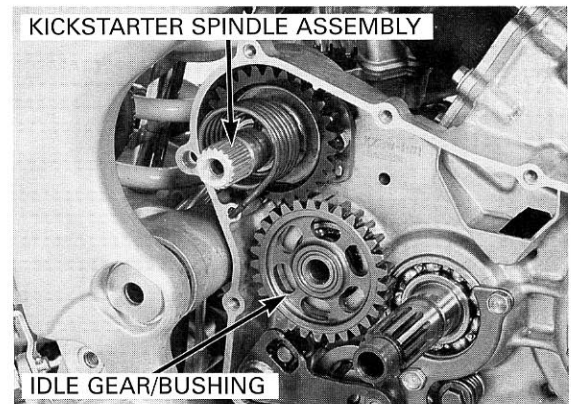

### DISASSEMBLY

Disassemble the kickstarter spindle by removing the following:

- Thrust washer and collar
- Return spring
- Ratchet spring and starter ratchet
- Snap ring, thrust washer and pinion gear

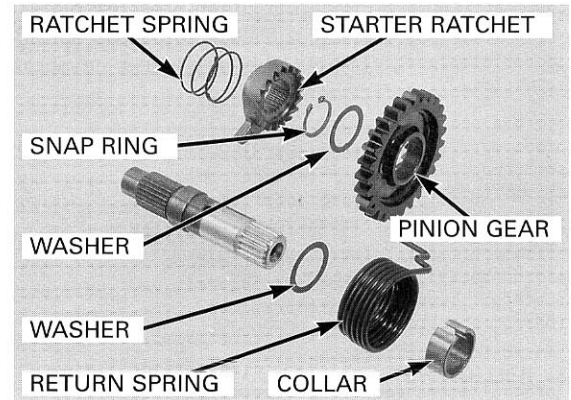

### INSPECTION

Check the return spring and ratchet spring for weakness or damage.

Check the starter ratchet for wear or damage.

Measure the kickstarter pinion gear I.D.

**SERVICE LIMIT: 22.05 mm (0.868 in)**

Measure the kickstarter spindle O.D.

**SERVICE LIMIT: 21.95 mm (0.864 in)**

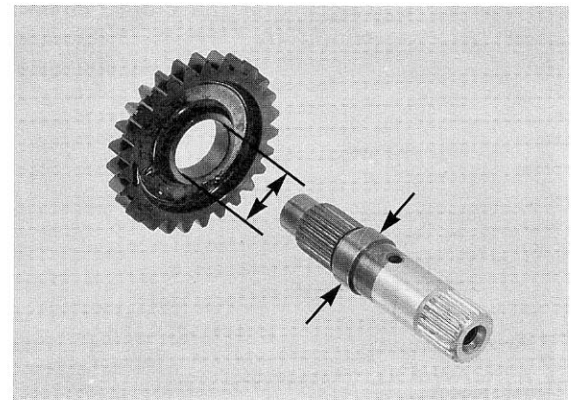

## CLUTCH/KICKSTARTER/GEARSHIFT LINKAGE

Check the starter idle gear and bushing for wear or damage.

Measure the starter idle gear I.D.

**SERVICE LIMIT: 20.07 mm (0.790 in)**

Measure the starter idle gear I.D.

**SERVICE LIMITS: I.D.: 17.04 mm (0.671 in)  
O.D.: 19.96 mm (0.786 in)**

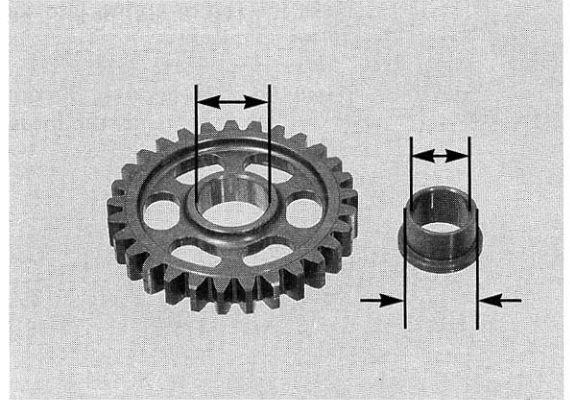

Measure the countershaft O.D. at the idle gear bushing sliding surface.

**SERVICE LIMIT: 16.95 mm (0.667 in)**

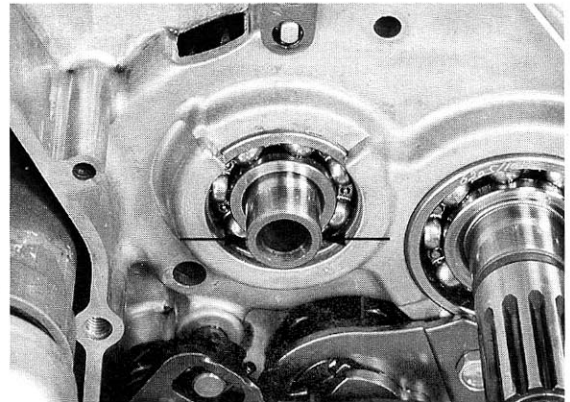

### ASSEMBLY

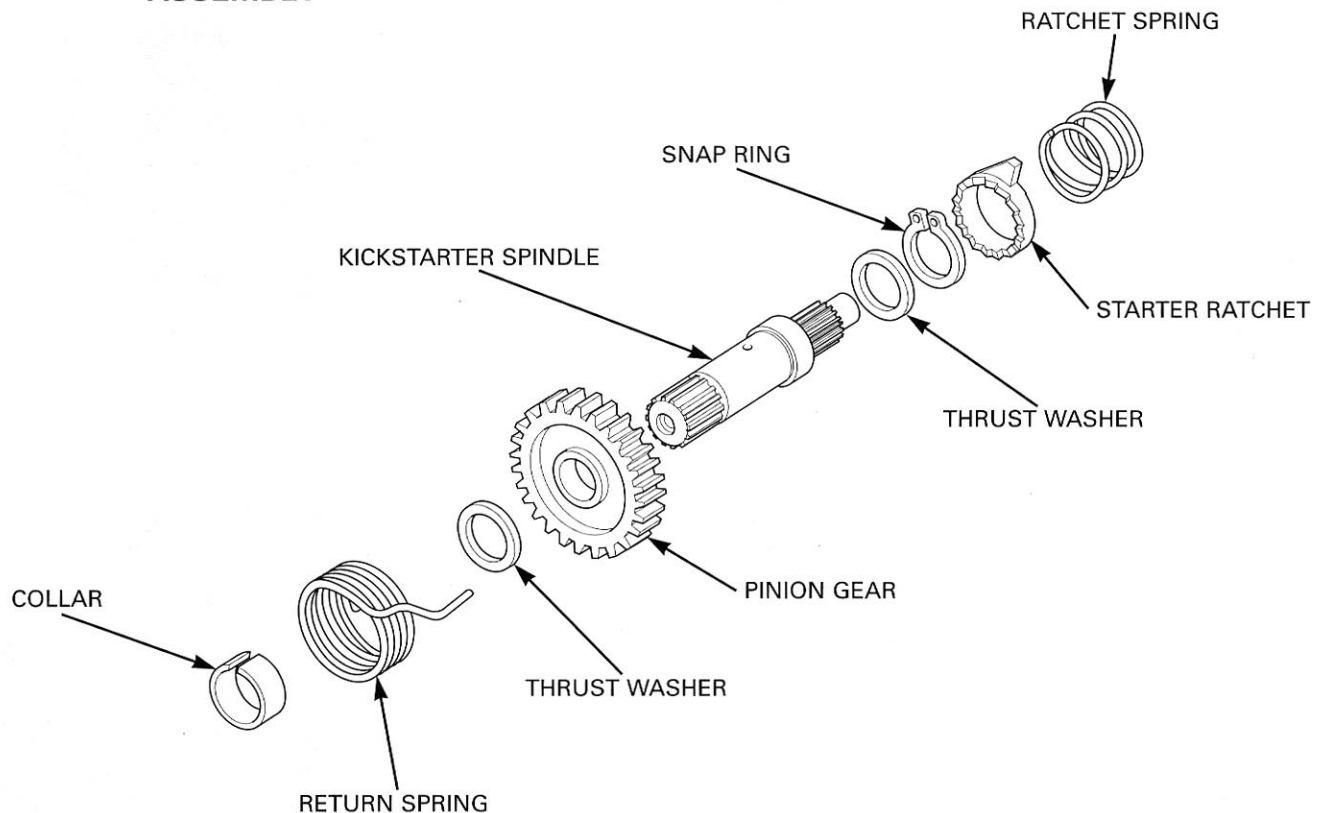

## CLUTCH/KICKSTARTER/GEARSHIFT LINKAGE

Insert the return spring into the spring hook on the starter spindle.

Install the collar aligning the groove of the collar with the spring, then install the thrust washer.

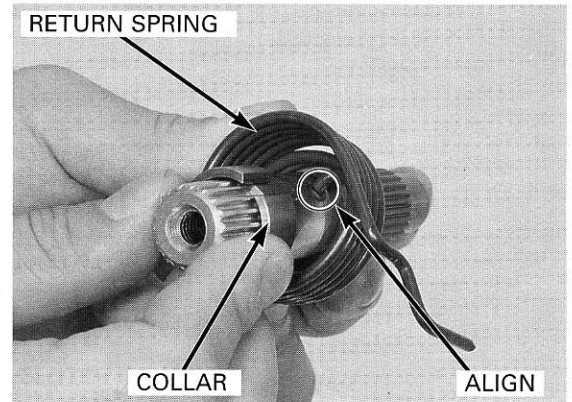

Install the pinion gear.  
Install the thrust washer.  
Install the snap ring in the groove of the spindle.

*Install the snap ring so the sharp edge faces out.*

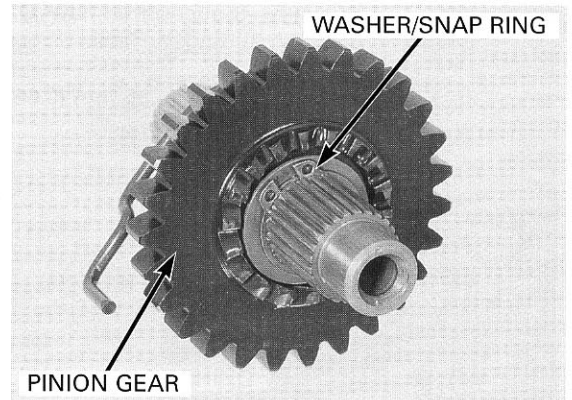

Align the punch marks and install the starter ratchet.  
Install the ratchet spring.

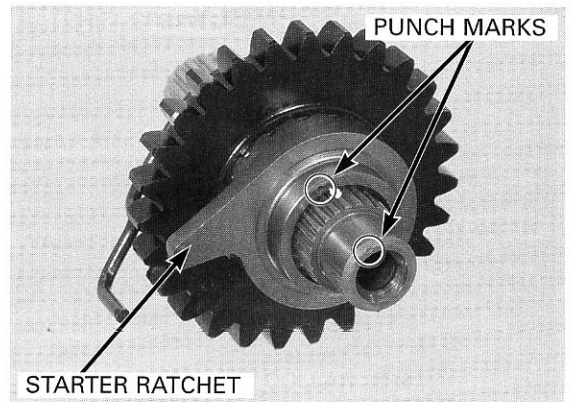

## INSTALLATION

Install the starter idle gear bushing to the countershaft.  
Install the starter idle gear to the countershaft.

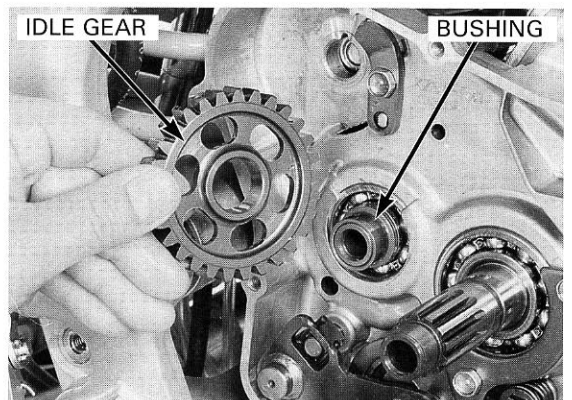

*Be sure to pre-tension the return spring before installing it into the crankcase.*

Install the kickstarter spindle and hook the return spring end to the crankcase.

Install the following:

- Clutch (page 9-9)
- Right crankcase cover (page 9-3)

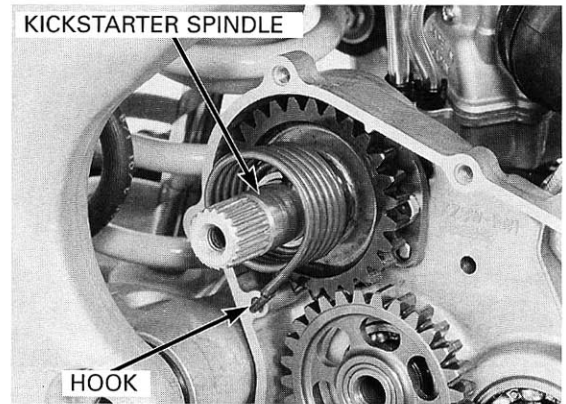

## GEARSHIFT LINKAGE

### REMOVAL

Remove the right crankcase cover (page 9-3).  
Remove the clutch (page 9-4).

Remove the bolt and gearshift pedal.

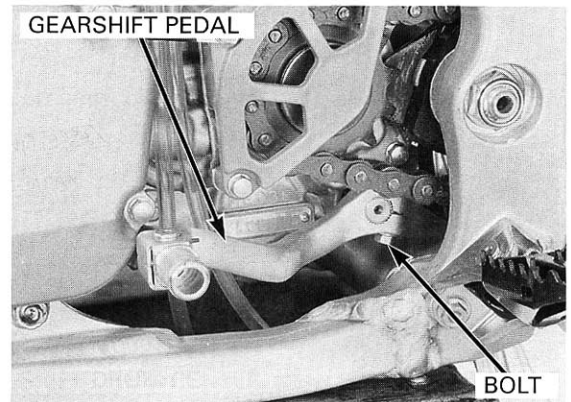

Remove the gearshift spindle from the crankcase.

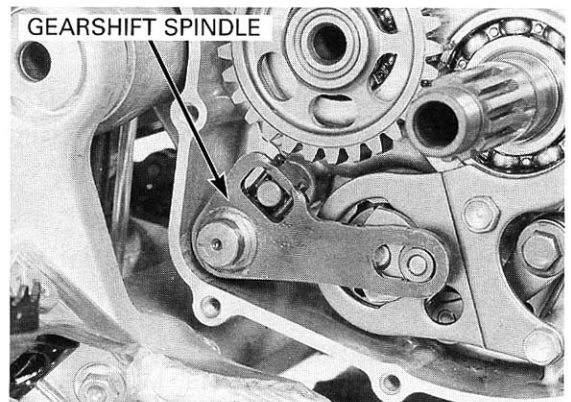

Remove the shifter collar.  
Remove the bolts.

Remove the guide plate and drum shifter as an assembly.

*Do not let the ratchet pawls fall when removing the guide plate and drum shifter.*

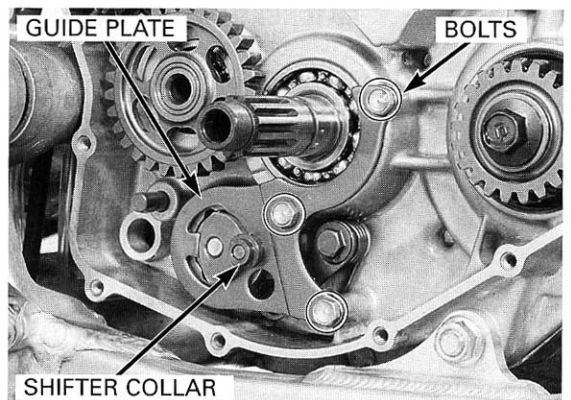

## CLUTCH/KICKSTARTER/GEARSHIFT LINKAGE

Remove the shift drum center pin and shift drum center.

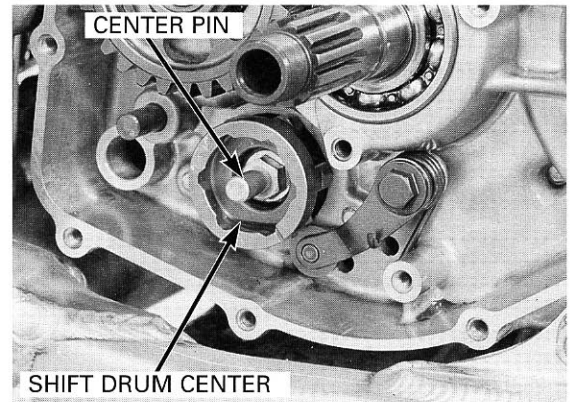

Remove the bolt, stopper arm, return spring and washer.

Remove the drum pin from the shift drum.

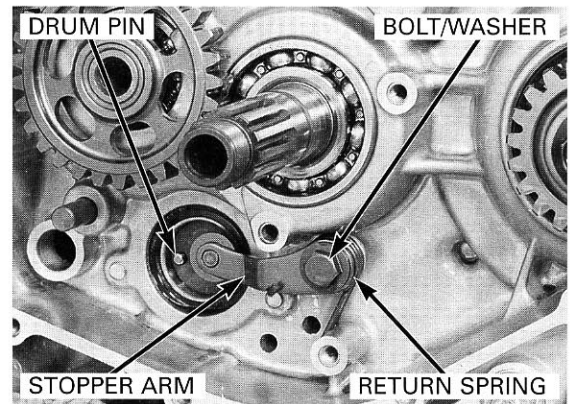

### INSPECTION

#### GEARSHIFT SPINDLE

Check the gearshift spindle for wear or damage.  
Check the return spring for fatigue or damage.

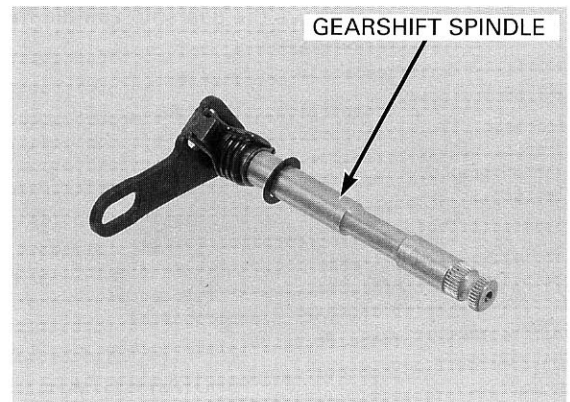

#### RATCHET PAWL

Clean the ratchet pawls, plungers, springs and drum shifter with clean transmission oil.

Check each part for wear or damage.

Apply clean transmission oil to each part.  
Assemble the drum shifter, springs, plungers and ratchet pawls in the guide plate as shown.

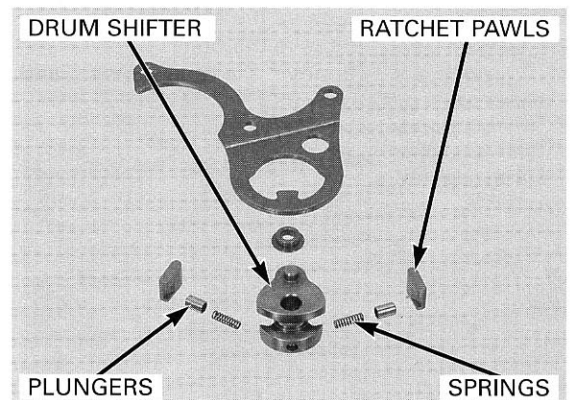

### INSTALLATION

Install the drum pin to the hole in the shift drum.

Install the return spring, washer and stopper arm and tighten the stopper arm bolt to the specified torque.

**TORQUE: 12 N·m (1.2 kgf·m, 9 lbf·ft)**

Check the stopper arm for proper operation.

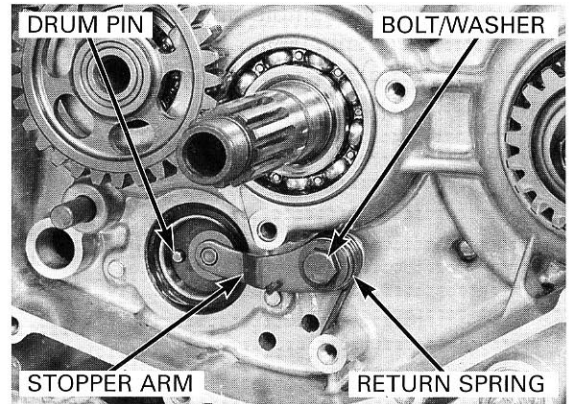

Move the stopper arm out of the way using a screwdriver.

Align the shift drum center hole with the drum pin and slip it into place.

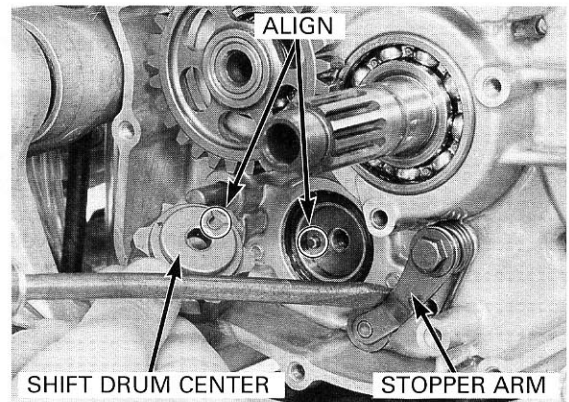

Clean and apply a locking agent to the gearshift drum center pin threads.

Install and tighten the shift drum center pin to the specified torque.

**TORQUE: 22 N·m (2.2 kgf·m, 16 lbf·ft)**

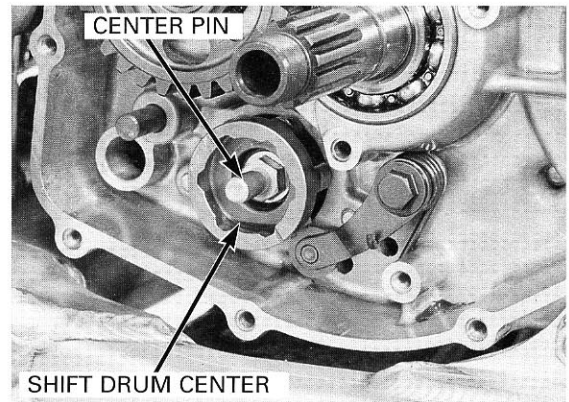

Position the drum center in a gear other than neutral. Holding the ratchet pawls in place in the guide plate and drum shifter, install the assembly onto the shift drum center pin.

Install and tighten the guide plate bolts securely. Install the shifter collar onto the drum shifter.

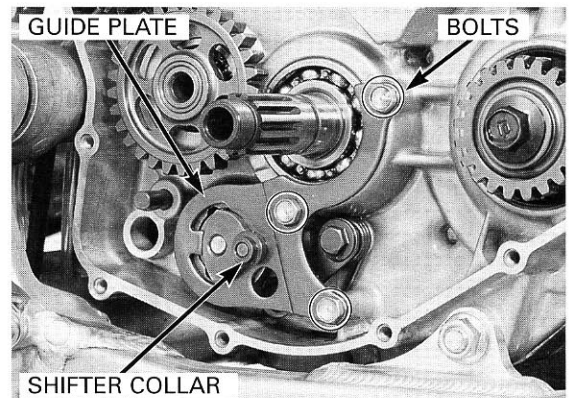

## CLUTCH/KICKSTARTER/GEARSHIFT LINKAGE

*Do not forget to install the washer onto the gearshift spindle.*

Assemble and install the washer to the gearshift spindle.

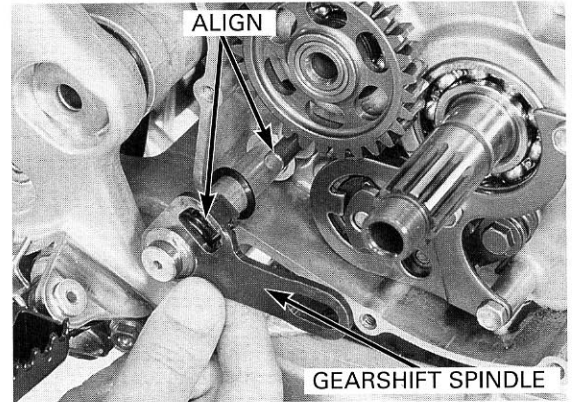

Install the gearshift pedal and bolt.  
Tighten the bolt to the specified torque.

**TORQUE: 12 N·m (1.2 kgf·m, 9 lbf·ft)**

Move the gearshift pedal and check the shift mechanism for smooth operation.

Install the kickstarter, if removed (page 9-14)  
Install the clutch (page 9-9).  
Install the right crankcase cover (page 9-3).

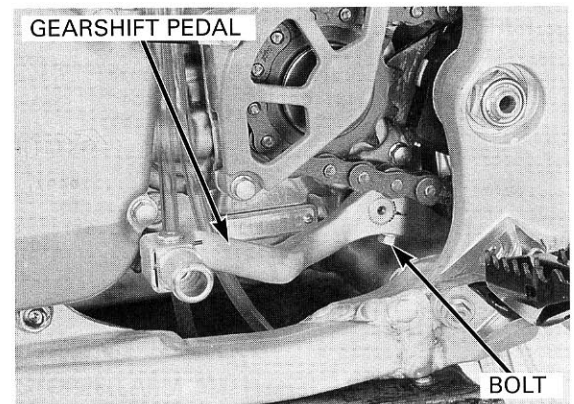

# CRANKCASE/CRANKSHAFT/TRANSMISSION

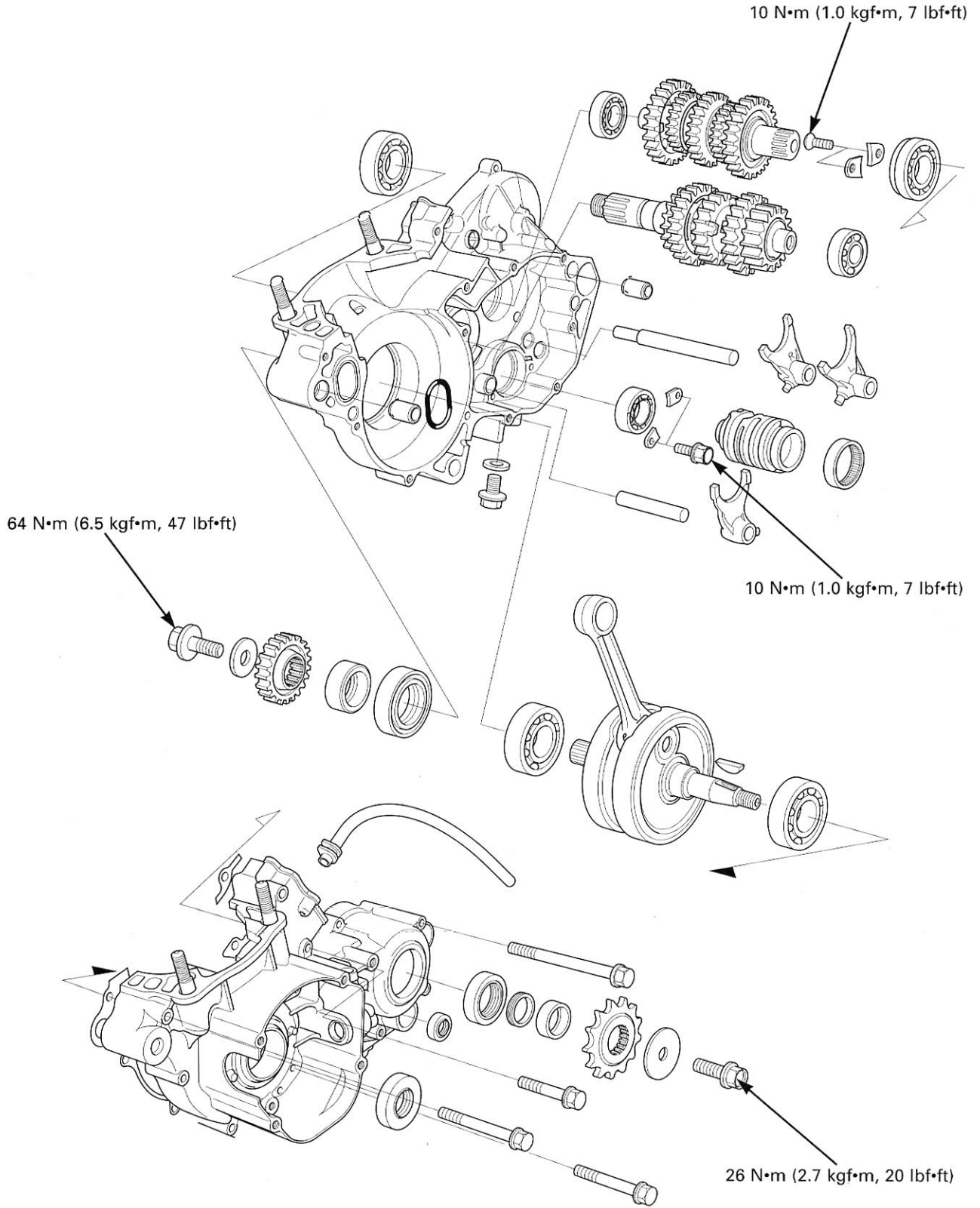



# 10. CRANKCASE/CRANKSHAFT/TRANSMISSION

SERVICE INFORMATION	10-1	CRANKCASE BEARING REPLACEMENT	10-9
TROUBLESHOOTING	10-3	CRANKSHAFT INSTALLATION	10-13
CRANKCASE SEPARATION	10-4	TRANSMISSION ASSEMBLY	10-14
TRANSMISSION DISASSEMBLY	10-6	CRANKCASE ASSEMBLY	10-16
CRANKSHAFT REMOVAL	10-8		

## SERVICE INFORMATION

### GENERAL

- This section covers crankcase separation for service of the crankshaft, transmission and kickstarter.
- The crankcase must be separated to service the crankshaft and transmission.
- The engine must be out of the frame for this service.
- The following parts must be removed before separating the crankcase.
  - Alternator (section 14)
  - Clutch/kickstarter/gearshift linkage (section 9)
  - Cylinder head/cylinder/piston (section 7)
  - Engine (section 6)

## CRANKCASE/CRANKSHAFT/TRANSMISSION

### SPECIFICATIONS

Unit: mm (in)

ITEM		STANDARD	SERVICE LIMIT	
Crankshaft	Side clearance	0.4 – 0.8 (0.02 – 0.03)	0.9 (0.04)	
	Radial clearance	0.010 – 0.022 (0.0004 – 0.0009)	0.03 (0.001)	
	Runout	—	0.05 (0.002)	
Transmission	Gear I.D.	M4	28.007 – 28.028 (1.1026 – 1.1035)	28.05 (1.104)
		M5	25.020 – 25.041 (0.9850 – 0.9859)	25.07 (0.987)
		C1	22.020 – 22.041 (0.8669 – 0.8678)	22.07 (0.869)
		C2	30.020 – 30.041 (1.1819 – 1.1827)	30.07 (1.184)
		C3	25.020 – 25.041 (0.9850 – 0.9859)	25.07 (0.987)
	Gear bushing O.D.	M4	27.959 – 27.980 (1.1007 – 1.1015)	27.94 (1.100)
		C1	21.979 – 22.000 (0.8653 – 0.8661)	21.95 (0.864)
		C2	29.979 – 30.000 (1.1802 – 1.1811)	29.95 (1.179)
	Gear bushing I.D.	C1	19.000 – 19.021 (0.7480 – 0.7489)	19.04 (0.750)
		C2	27.000 – 27.021 (1.0630 – 1.0638)	27.04 (1.064)
	Gear-to-bushing clearance	M4	0.027 – 0.069 (0.0011 – 0.0027)	0.11 (0.004)
		C1	0.020 – 0.062 (0.0008 – 0.0024)	0.12 (0.005)
		C2	0.020 – 0.062 (0.0008 – 0.0024)	0.12 (0.005)
	Mainshaft O.D.	at M5	24.959 – 24.980 (0.9826 – 0.9835)	24.94 (0.982)
	Countershaft O.D.	at C1 bushing	18.959 – 18.980 (0.7464 – 0.7472)	18.94 (0.746)
		at C2 bushing	26.959 – 26.980 (1.0614 – 1.0622)	26.94 (1.061)
		at C3	24.959 – 24.979 (0.9826 – 0.9834)	24.96 (0.983)
	Gear-to-shaft clearance	M5	0.040 – 0.082 (0.0016 – 0.0032)	0.13 (0.005)
		C3	0.041 – 0.082 (0.0016 – 0.0032)	0.11 (0.004)
	Bushing-to-shaft clearance	C1	0.020 – 0.062 (0.0008 – 0.0024)	0.12 (0.005)
		C3	0.020 – 0.062 (0.0008 – 0.0024)	0.12 (0.005)
Shift fork, fork shaft	Fork claw thickness	4.93 – 5.00 (0.194 – 0.197)	4.8 (0.19)	
	Shift fork I.D.	C	11.003 – 11.024 (0.4332 – 0.4340)	11.04 (0.435)
		R/L	12.035 – 12.056 (0.4738 – 0.4746)	12.07 (0.475)
	Fork shaft O.D.	C	10.983 – 10.994 (0.4324 – 0.4328)	10.97 (0.432)
		R/L	11.966 – 11.984 (0.4711 – 0.4718)	11.95 (0.470)

### TORQUE VALUES

Primary drive gear bolt

64 N•m (6.5 kgf•m, 47 lbf•ft)

Drive sprocket bolt

26 N•m (2.7 kgf•m, 20 lbf•ft)

Countershaft bearing set plate screw

10 N•m (1.0 kgf•m, 7 lbf•ft) Apply a locking agent to the threads.

Gearshift drum bearing set plate bolt

10 N•m (1.0 kgf•m, 7 lbf•ft) Apply a locking agent to the threads.

**TOOLS**

Universal bearing puller	07631-0010000 or equivalent commercially available in U.S.A.
Gear holder, 2.5	07724-0010100 or 07724-001A100 (U.S.A. only)
Universal holder	07725-0030000
Attachment, 37 x 40 mm	07746-0010200
Attachment, 42 x 47 mm	07746-0010300
Attachment, 62 x 68 mm	07746-0010500
Pilot, 17 mm	07746-0040400
Pilot, 25 mm	07746-0040600
Pilot, 28 mm	07746-0041100
Driver	07749-0010000
Bearing remover, 17 mm	07936-3710300 or 07936-3710200
— Remover handle	07936-3710100
— Remover weight	07741-0010201 or 07936-3710200 or 07936-371020A (U.S.A. only)
Crankcase puller	07937-4300000 or 07937-4300001
— Bolt, 6 mm	07PMC-KZ40100 (or use two 6 x 100 mm bolts)
Crankcase assembly tool set	07965-1660100 (Not available in U.S.A.) or 07965-1660101 or 07965-1660102
— Assembly tool shaft	07965-1660200
— Assembly collar	07965-1660300 (Not available in U.S.A.) or 07965-1660301 or 07965-1660302 or 07965-166030A (U.S.A. only)
Thread adapter	07965-KA30000
Assembly collar	07965-VM00100
Threaded shaft	07965-VM00200 or 07931-ME4010B and 07931-HB3020A (U.S.A. only)

**TROUBLESHOOTING****Excessive noise**

- Worn crankpin bearing
- Worn transmission bearing (s)
- Worn crankshaft bearing (s)

**Transmission jumps out of gear**

- Worn gear dogs and slots
- Bent fork shaft
- Broken shift drum stopper
- Worn or bent shift forks
- Broken shift linkage return spring

**Hard to shift**

- Improper clutch operation
- Incorrect transmission oil weight
- Incorrect clutch adjustment
- Bent shift fork
- Bent fork shaft
- Bent fork claw
- Damaged shift drum cam grooves
- Bent shift spindle

**Engine vibration**

- Excessive crankshaft runout

### CRANKCASE SEPARATION

Refer to service information (page 10-1) for removal of necessary parts before separating the crankcase.

Remove the drive sprocket guard by removing the two bolts.

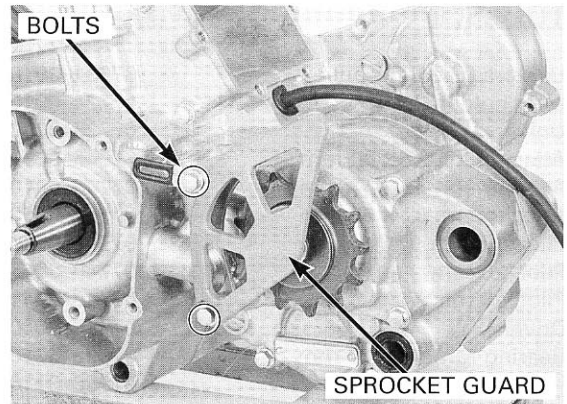

Loosen the drive sprocket bolt while holding the sprocket with the universal holder.

**TOOL:**

**Universal holder**

**07725-003000**

Remove the cone spring washer and drive sprocket.

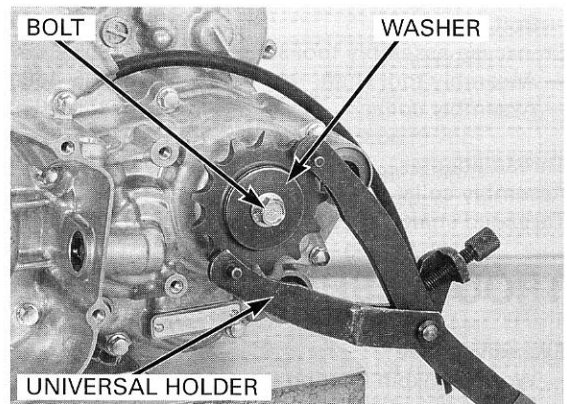

Temporarily install the clutch outer guide, needle bearing and clutch outer onto the mainshaft.

Insert the gear holder between the primary drive and driven gear.

Remove the primary drive gear bolt, then remove the washer and drive gear.

**TOOL:**

**Gear holder, 2.5**

**07724-0010100 or  
07724-001A100  
(U.S.A. only)**

Check the primary drive gear for wear or damage.

Remove the clutch outer, needle bearing and outer guide.

Remove the collar from the crankshaft.

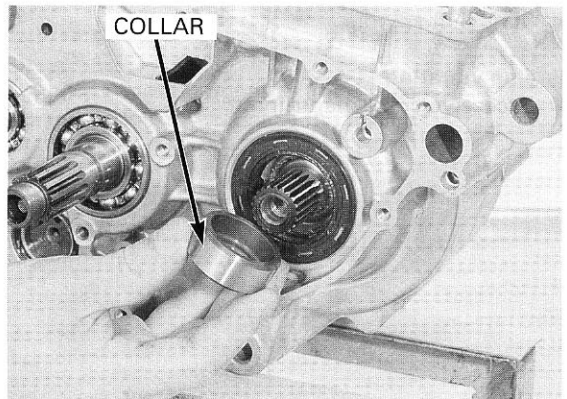
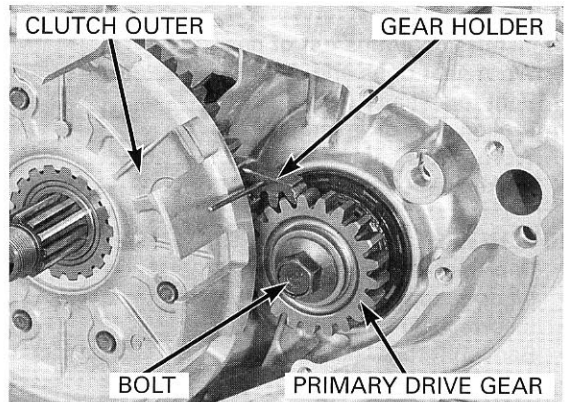

Remove the countershaft collar and O-ring.

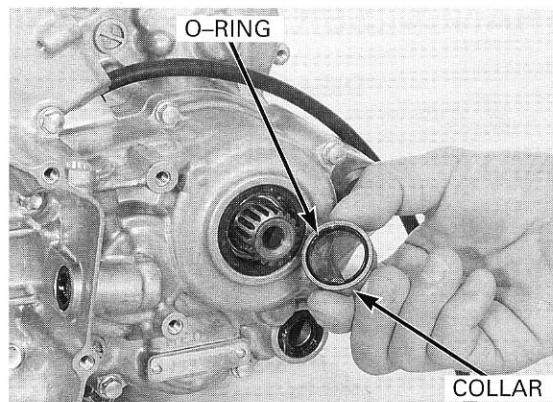

Loosen the crankcase bolts in a crisscross pattern in two or three steps.  
Remove the 12 crankcase bolt.

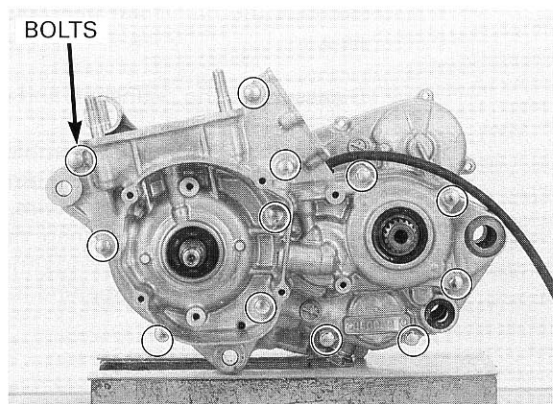

*Do not pry the crankcase halves apart with a screwdriver.*

Attach the crankcase puller to the left crankcase. Separate the right and left crankcase from each other while tapping them at several locations with a soft hammer.

**TOOLS:**

**Crankcase puller**

**Bolt, 6 mm**

**Crankcase puller**

**07937-430000 and**

**07PMC-KZ40100 or**

**07937-430001**

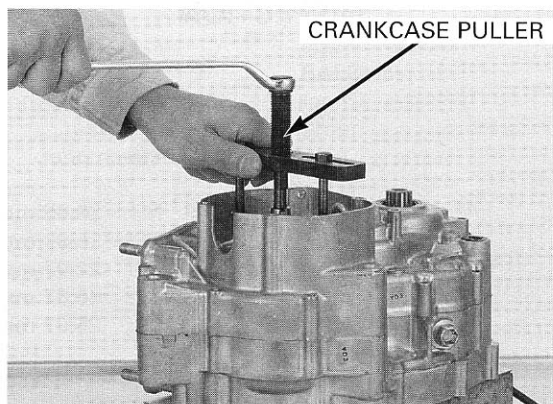

Remove the gaskets, dowel pins and breather hose.

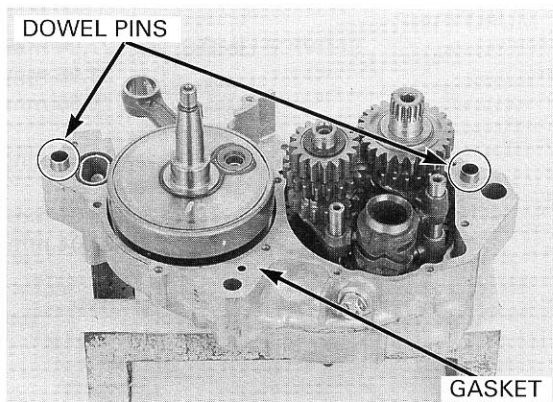

## TRANSMISSION DISASSEMBLY

### DISASSEMBLY

Separate the crankcase halves (page 10-4).

Remove the shift fork shafts and shift forks.

Remove the shift drum.

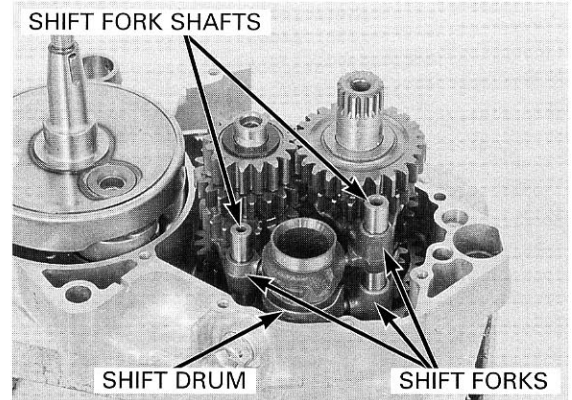

Remove the mainshaft and countershaft assemblies as a set.

Disassemble the mainshaft and countershaft.

- Keep track of the disassembled parts (gears, bushings, washers, and snap rings) by sliding them onto a tool or a piece of wire.
- Do not remove the snap rings over the shafts, expand the snap ring ends and slide it off the shaft, along with the gear behind it.

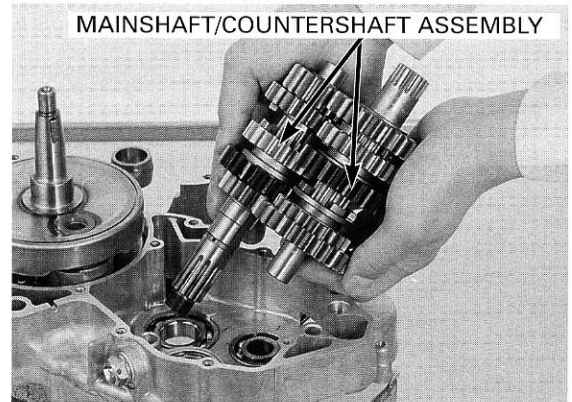

### INSPECTION

#### GEAR

Check the gear dogs, dog holders and teeth for damage or excessive wear.

Measure the I.D. of each gear.

<b>SERVICE LIMITS:</b>	<b>M4:</b>	<b>28.05 mm (1.104 in)</b>
	<b>M5:</b>	<b>25.07 mm (0.987 in)</b>
	<b>C1:</b>	<b>22.07 mm (0.869 in)</b>
	<b>C2:</b>	<b>30.07 mm (1.184 in)</b>
	<b>C3:</b>	<b>25.07 mm (0.987 in)</b>

#### BUSHING

Check the bushings for damage or excessive wear.

Measure the O.D. of each bushing.

<b>SERVICE LIMITS:</b>	<b>M4:</b>	<b>27.94 mm (1.100 in)</b>
	<b>C1:</b>	<b>21.95 mm (0.864 in)</b>
	<b>C2:</b>	<b>29.95 mm (1.179 in)</b>

Measure the I.D. of each bushing.

<b>SERVICE LIMITS:</b>	<b>C1:</b>	<b>19.04 mm (0.750 in)</b>
	<b>C2:</b>	<b>27.04 mm (1.064 in)</b>

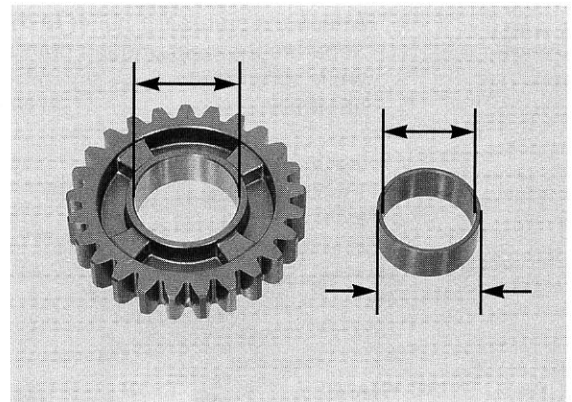

## MAINSHAFT/COUNTERSHAFT

Check the spline grooves and sliding surfaces for damage or abnormal wear.  
Measure the O.D. of the mainshaft and countershaft at the gear and bushing sliding area.

### SERVICE LIMITS:

Mainshaft: M5: 24.94 mm (0.982 in)

Countershaft: C3: 24.96 mm (0.983 in)

C1 bushing: 18.94 mm (0.746 in)

C2 bushing: 26.94 mm (1.061 in)

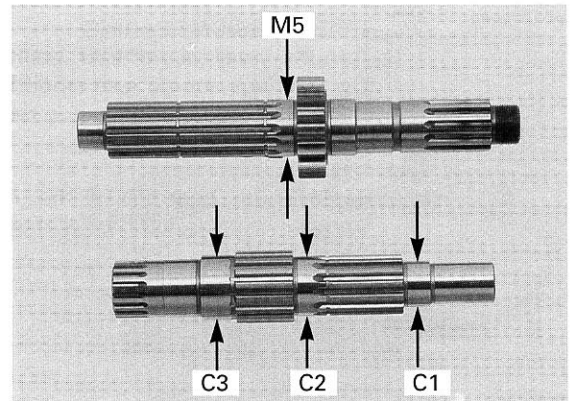

## SHIFT FORK

Check the shift fork for abnormal wear or deformation.  
Measure the shift fork I.D. and claw thickness.

### SERVICE LIMITS:

I.D.: Center: 11.04 mm (0.435 in)

Right and left: 12.07 mm (0.475 in)

Claw thickness: 4.8 mm (0.19 in)

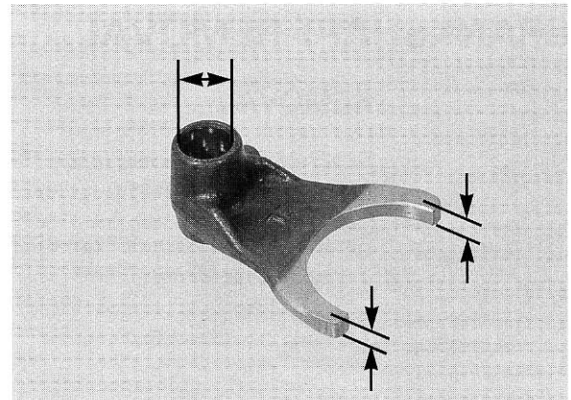

## SHIFT FORK SHAFT

Check the shift fork shaft for abnormal wear or deformation.  
Measure the shift fork shaft O.D.

### SERVICE LIMITS:

Center: 10.97 mm (0.432 in)

Right and left: 11.95 mm (0.470 in)

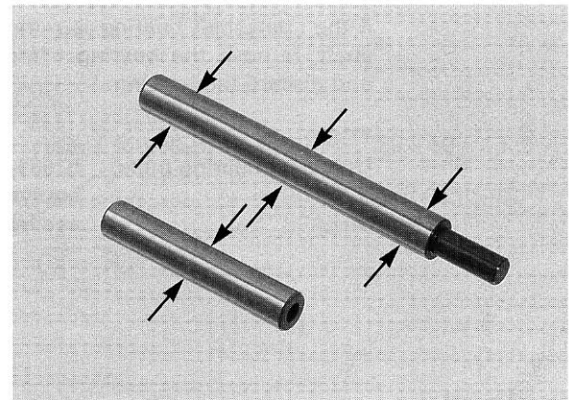

## SHIFT DRUM

Inspect the shift drum for scoring, scratches or evidence of insufficient lubrication.  
Check the shift drum grooves for abnormal wear or damage.

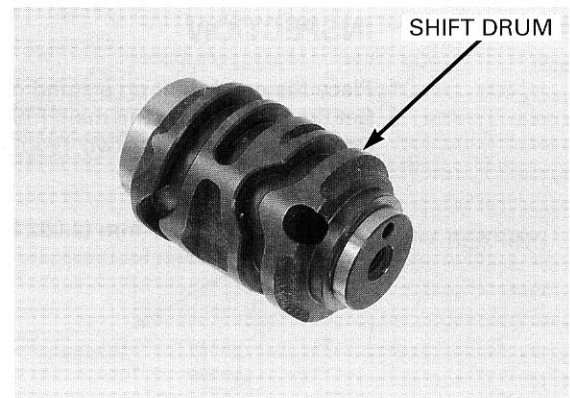

## TRANSMISSION BEARING

Turn the inner race of each bearing with your finger. The bearings should turn smoothly and quietly. Also check that the bearing outer race fits tightly in the crankcase.

Replace the bearings if the race does not turn smoothly and quietly, or if they fits loosely in the crankcase (page 10-9).

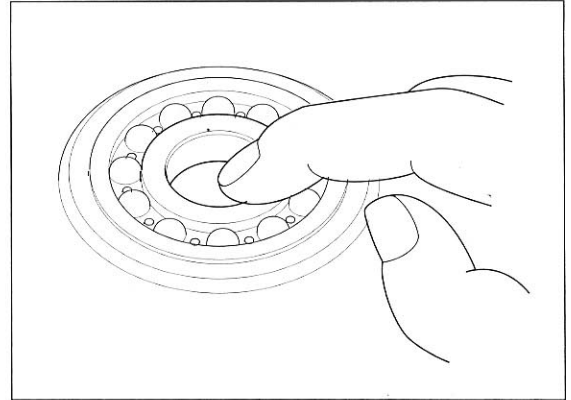

## CRANKSHAFT REMOVAL

### REMOVAL

Separate the crankcase (page 10-4).  
Remove the transmission (page 10-6).

*When removing, installing and inspecting the crankshaft, be careful not to damage or nick the hollow crank weight.*

Remove the crankshaft from the right crankcase using a hydraulic press as shown.

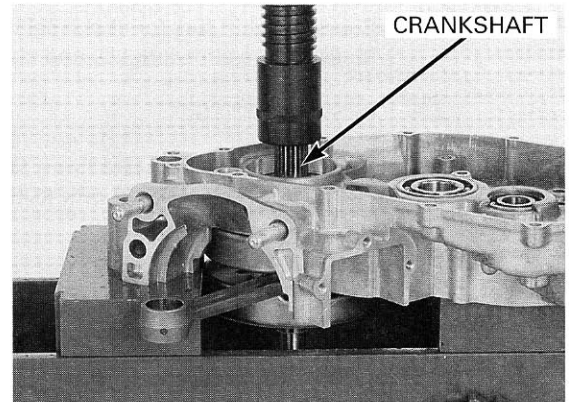

If the crankshaft bearing is removed with the crankshaft, remove the bearing using the bearing puller and discard the bearing.

### TOOL:

**Universal bearing puller 07631-0010000 or equivalent commercially available in U.S.A.**

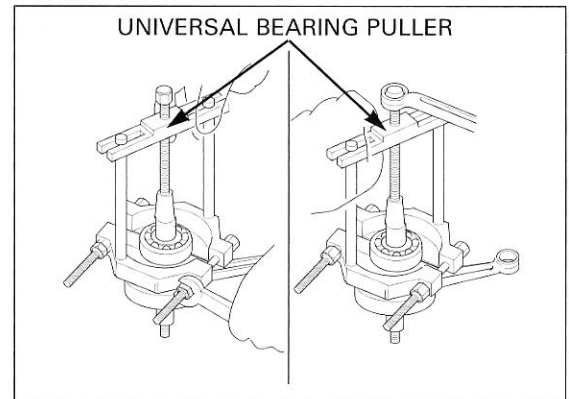

### INSPECTION

Place the crankshaft on a stand or V-blocks.  
Set the indicator on the main journal.  
Rotate the crankshaft two revolutions and read the runout.

**SERVICE LIMIT: 0.05 mm (0.002 in)**

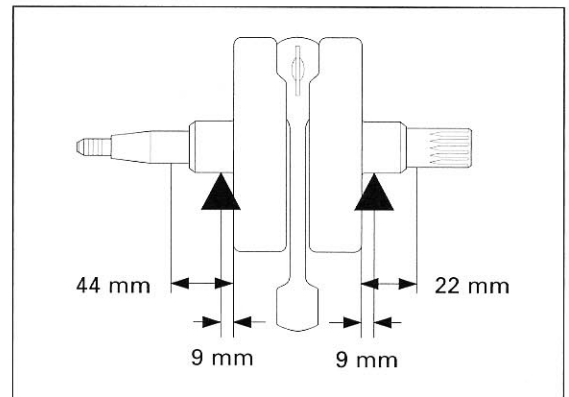



Measure the connecting rod big end axial/radial play.

**SERVICE LIMIT: 0.03 mm (0.001 in)**

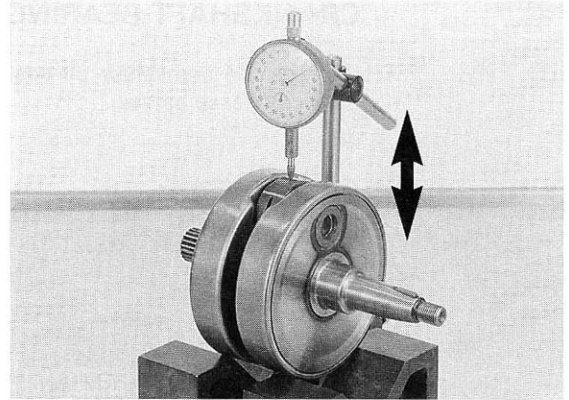

Measure the connecting rod big end side clearance.

**SERVICE LIMIT: 0.9 mm (0.04 in)**

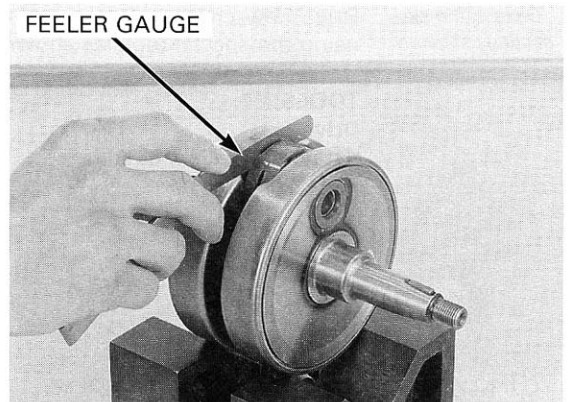

## CRANKCASE BEARING REPLACEMENT

### CRANKCASE BEARING/OIL SEAL LOCATION

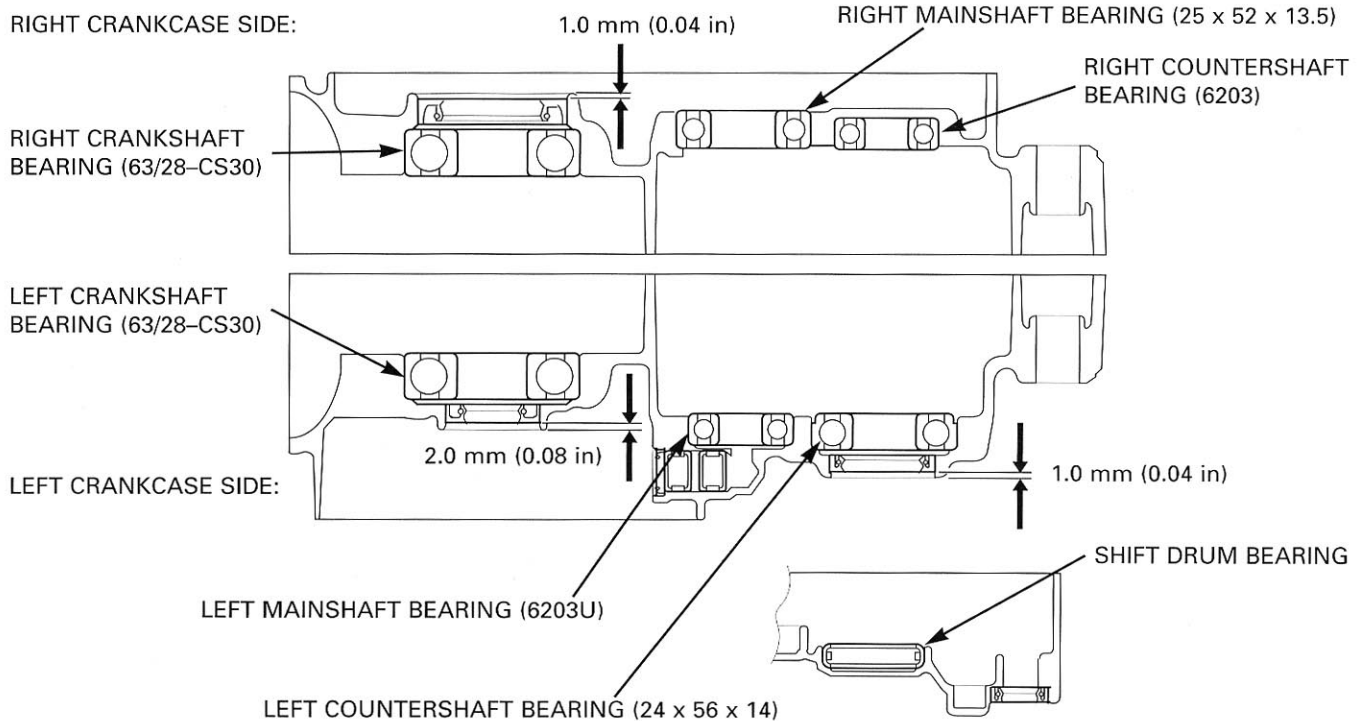

## CRANKCASE/CRANKSHAFT/TRANSMISSION

### CRANKSHAFT BEARING

Remove the crankshaft oil seals and bearings from both crankcase halves.

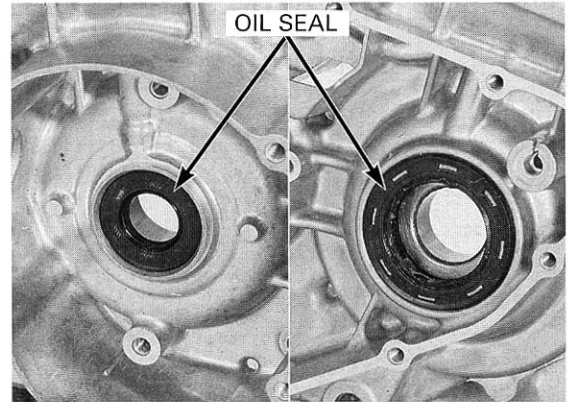

*Drive in the new bearings squarely.*

Drive new crankshaft bearings into both crankcases using the special tools as shown.

#### TOOLS:

Driver	07746-0010000
Attachment, 62 x 68 mm	07746-0010500
Pilot, 28 mm	07746-0041100

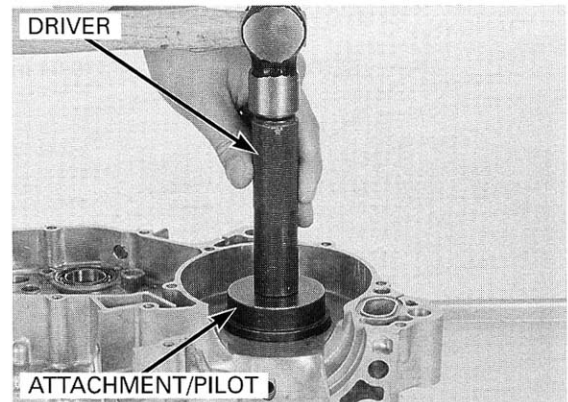

### TRANSMISSION BEARINGS

#### LEFT CRANKCASE

Remove the countershaft oil seal.

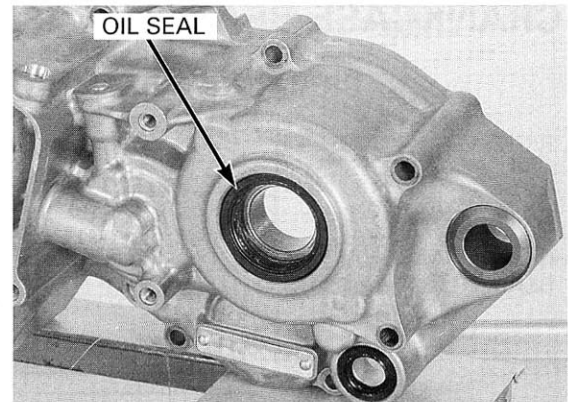

Remove the screws and countershaft bearing set plates.

Remove the countershaft bearing and shift drum bearing.

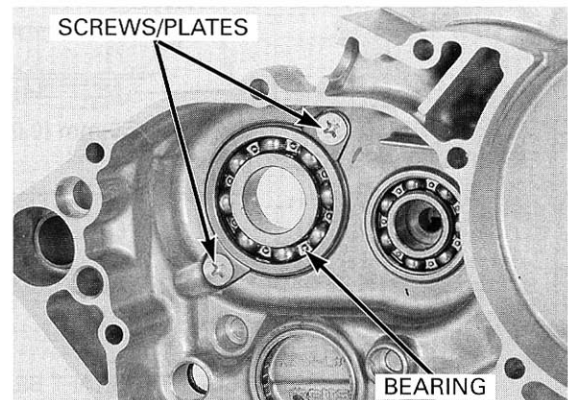

## CRANKCASE/CRANKSHAFT/TRANSMISSION

Remove the mainshaft bearing using the special tools as shown.

### TOOLS:

<b>Bearing remover, 17 mm</b>	07936-3710300
— Remover handle	07936-3710100
— Remover weight	07741-0010201 or 07936-3710200 or 07936-371020A (U.S.A. only)

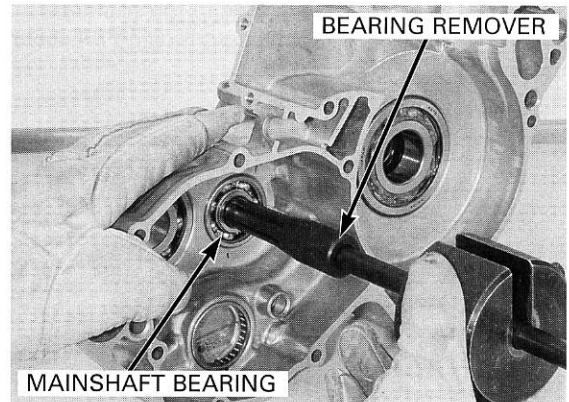

*Drive in the new bearings squarely.*

Drive in a new bearings into the left crankcase using the special tools as shown.

### TOOLS:

<b>Shift drum bearing:</b>	
Driver	07749-0010000
Attachment, 37 x 40 mm	07746-0010200

### Mainshaft bearing:

Driver	07749-0010000
Attachment, 42 x 47 mm	07746-0010300
Pilot, 17 mm	07746-0040400

### Countershaft bearing:

Driver	07749-0010000
Attachment, 42 x 47 mm	07746-0010300

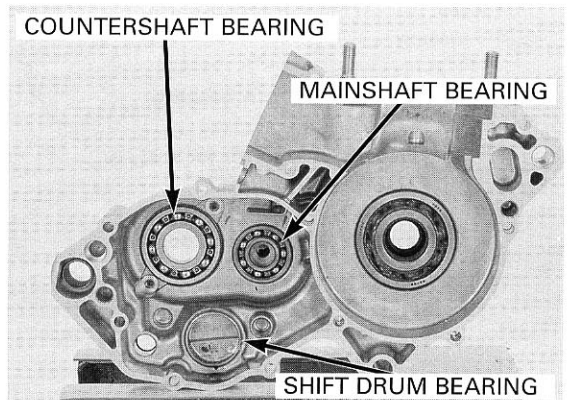
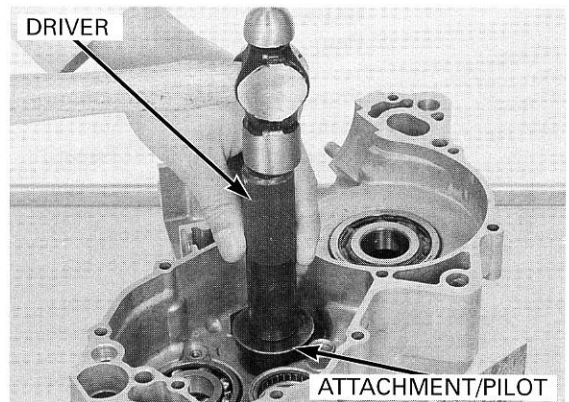

Clean and apply a locking agent to the countershaft bearing set plate screws and tighten the screws with the set plates.

**TORQUE: 10 N·m (1.0 kgf·m, 7 lbf·ft)**

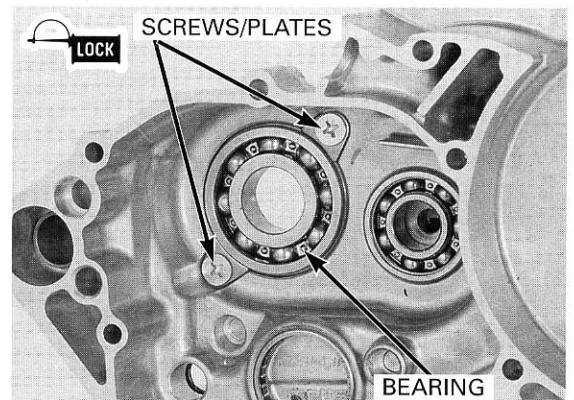

## CRANKCASE/CRANKSHAFT/TRANSMISSION

Apply grease to the countershaft oil seal lips.  
Install the countershaft oil seal flush with the case as shown.

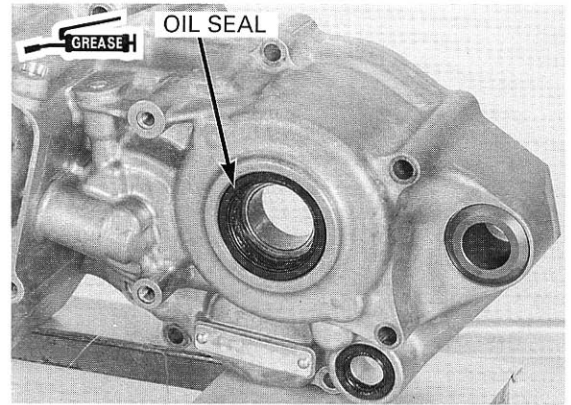

### RIGHT CRANKCASE

Remove the mainshaft and countershaft bearings.

Remove the shift drum bearing set plate bolts and set plates.

Remove the shift drum bearing.

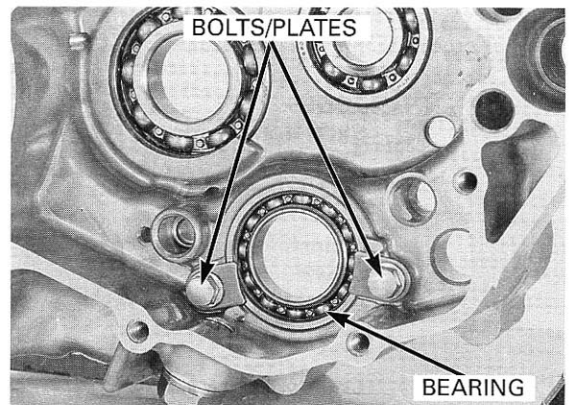

*Drive in the new bearings squarely.*

Drive in new bearings into the right crankcase.

#### TOOLS:

##### Shift drum bearing:

Driver	07749-0010000
Attachment, 42 x 47 mm	07746-0010300
Pilot, 25 mm	07746-0040600

##### Mainshaft bearing:

Driver	07749-0010000
Attachment, 52 x 55 mm	07746-0010400
Pilot, 25 mm	07746-0040600

##### Countershaft bearing:

Driver	07749-0010000
Attachment, 37 x 40 mm	07746-0010200
Pilot, 17 mm	07746-0040400

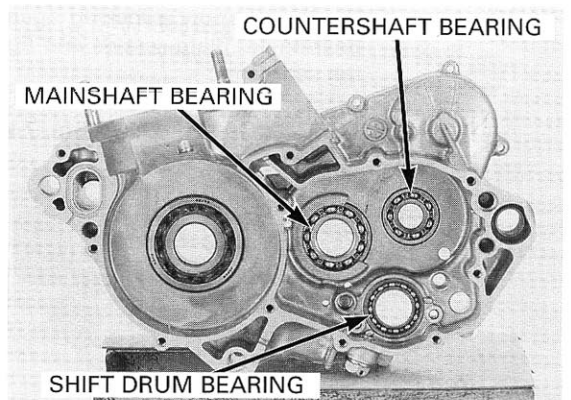
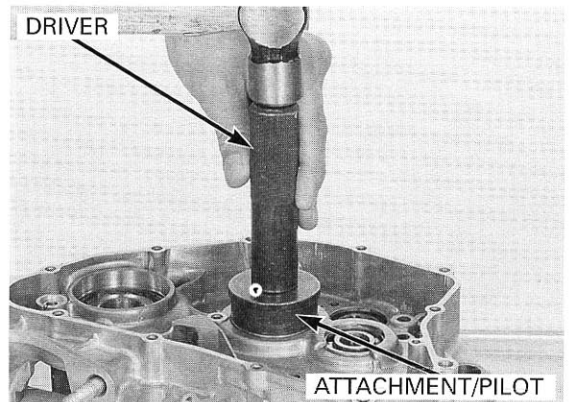

Clean and apply a locking agent to the shift drum bearing set plate bolts and tighten the bolts with the set plates.

**TORQUE: 10 N·m (1.0 kgf·m, 7 lbf·ft)**

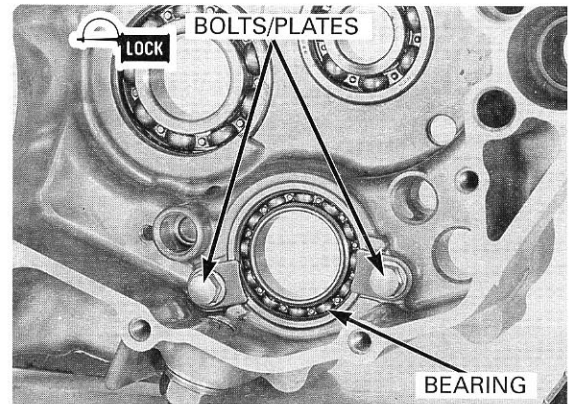

## CRANKSHAFT INSTALLATION

Clean both crankcase mating surfaces before assembling and check for wear or damage.

- If there is minor roughness or irregularities on the crankcase mating surfaces, dress them with an oil stone.
- After cleaning, lubricate the crankshaft bearings with recommended clean 2-stroke oil.

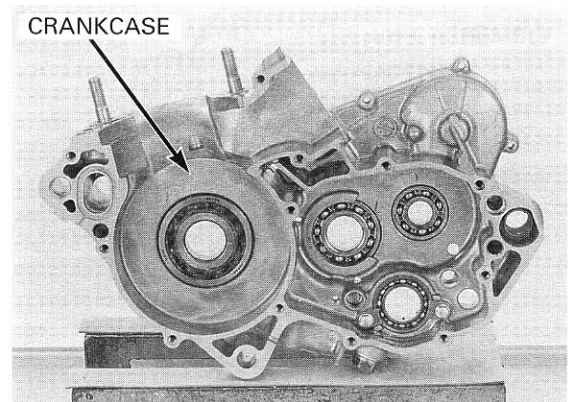

Install the threaded adaptor on to the crankshaft.

**TOOL:**

**Threaded adaptor**                      **07965-KA30000**

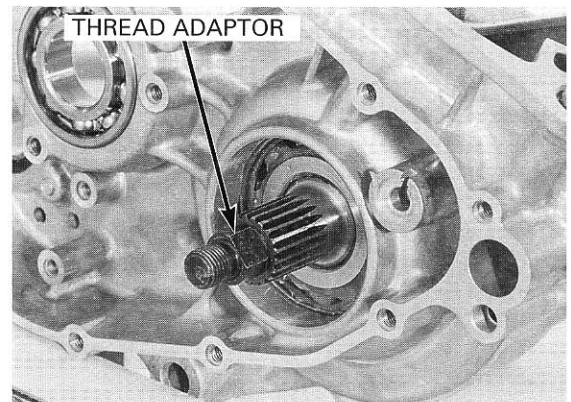

Install the crankshaft into the right crankcase using the special tools.

**TOOLS:**

**Crankcase assembly tool set**    **07965-1660100 or 07965-1660101 or 07965-1660102 not available in U.S.A. 07965-1660200**  
 — Assembly tool shaft            **07965-1660300 or 07965-1660301 or 07965-1660302 or 07965-166030A (U.S.A. only)**  
 — Assembly collar

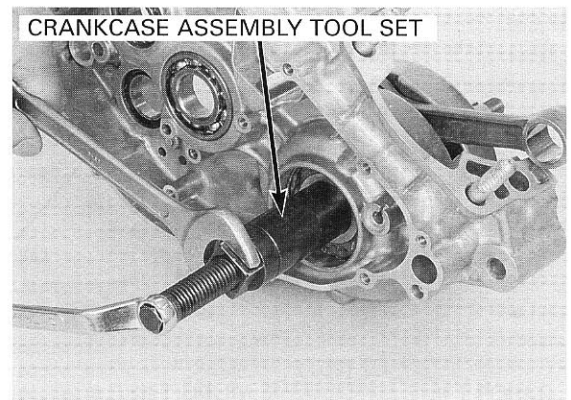

# TRANSMISSION ASSEMBLY

Clean all parts in solvent.  
Assemble all parts into original positions.

## MAINSHAFT:

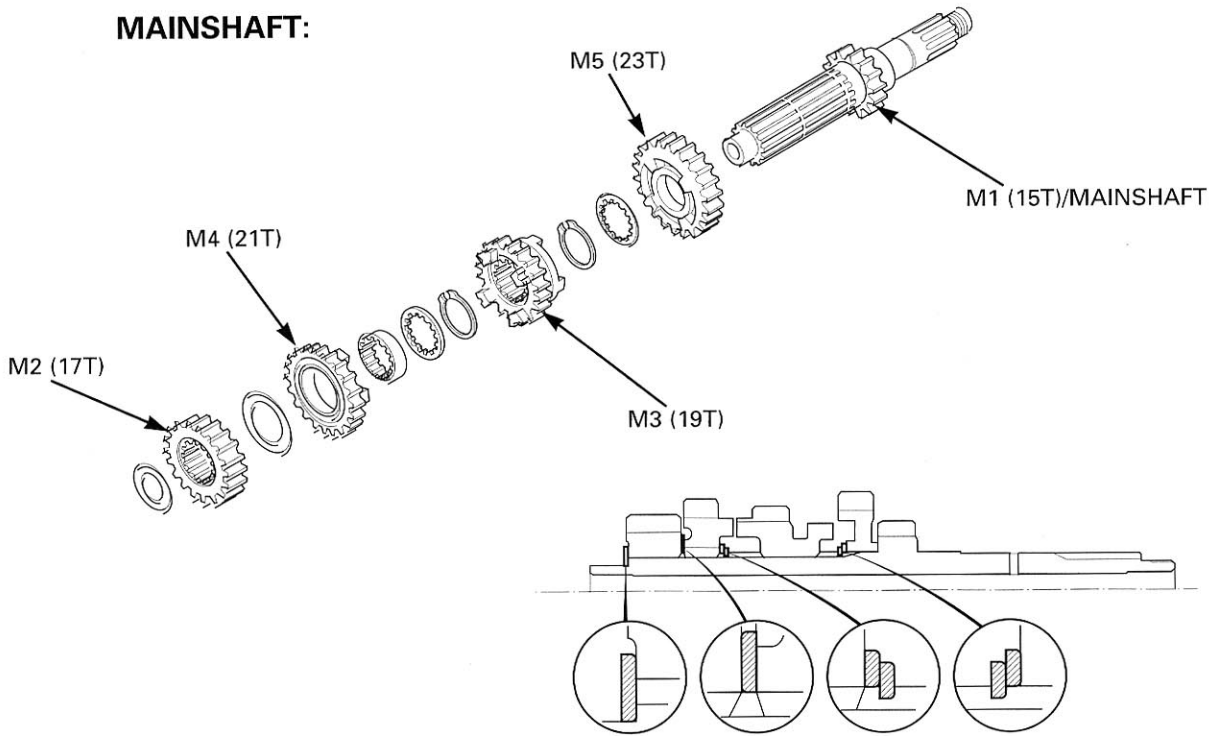

## COUNTERSHAFT:

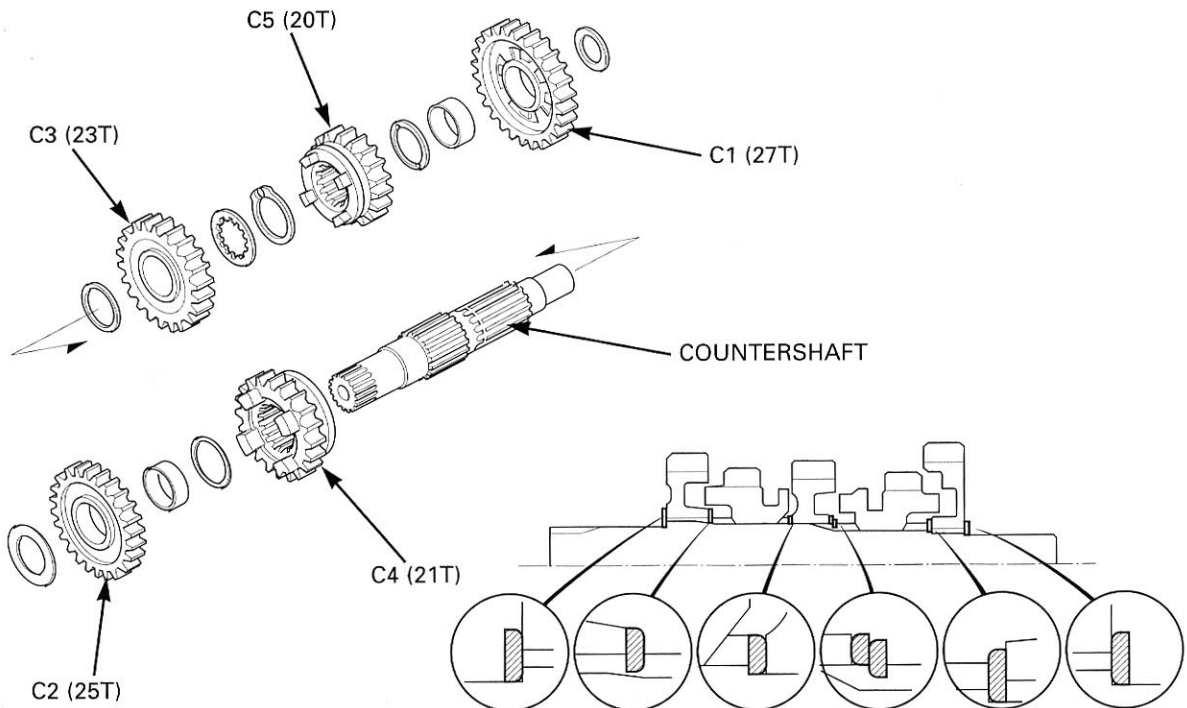

- Check the gears for smooth movement or rotation on the shaft.
- Install the washers and snap rings with the chamfered edge facing the thrust load side.
- Do not reuse worn snap rings which could easily spin in the grooves.
- Check that the snap rings are seated in the grooves. Align their end gaps with the grooves in the spline.

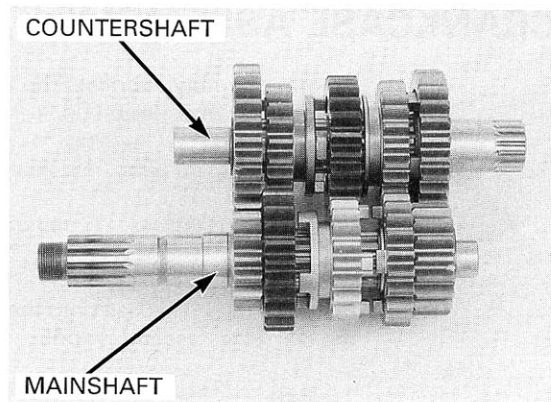

Apply transmission oil to the following parts:

- Mainshaft
- Countershaft
- Each gear
- Mainshaft bearing
- Countershaft bearing
- Shift drum bearing

Engage the mainshaft and countershaft gears and place the transmission assembly into the right crankcase.

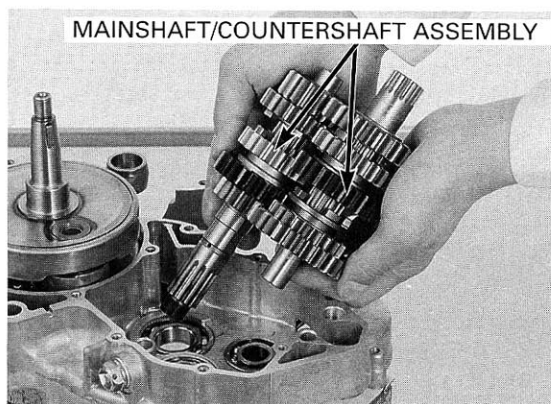

- Each shift fork has an identification mark; "R" is for the right shift fork, "L" is the left shift fork and "C" is for the center shift fork.
- Align the shift fork marks as follows:
  - Right and left fork marks to the left crankcase
  - Center fork mark to the right crankcase

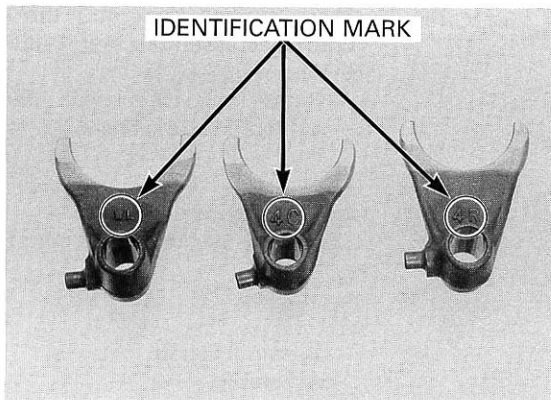

Apply transmission oil to the following parts:

- Shift drum guide grooves
- Shift fork claws and guide pins
- Shift fork sliding surfaces
- Shift fork shaft

Install the shift forks to the grooves of the shifter gear. Install the shift drum aligning the guide pins on the shift forks with the guide grooves of the shift drum.

Slide the shift fork shafts through the shift forks, and into the crankcase.

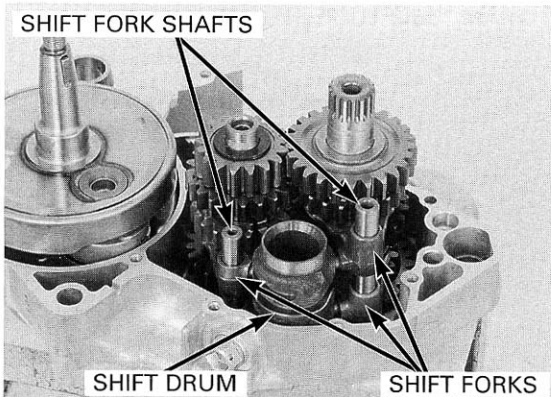

**CRANKCASE ASSEMBLY**

Before assembly, lubricate the transmission bearings with clean transmission oil.

Install the dowel pins, new gasket and new O-ring.

Install the crankcase breather hose onto the left crankcase.

Place the left crankcase onto the right crankcase using the crankcase assembly tool.

**TOOLS:**

- Crankcase assembly tool set** 07965-1660100 or 07965-1660101 or 07965-1660102 not available in U.S.A.
- Assembly tool shaft 07965-1660200
  - Assembly collar 07965-1660300 or 07965-1660301 or 07965-1660302 or 07965-166030A (U.S.A. only)

Pack grease into the cavity between the oil seal lips.

Press the oil seal into the crankcase using the crankcase assembly tool to the specified depth from the crankcase surfaces.

- Right crankcase oil seal: 1.0 mm (0.4 in)
- Left crankcase oil seal: 2.0 mm (0.8 in)

**TOOLS:**

**Left crankcase oil seal:**

- Crankcase assembly tool set** 07965-1660100 or 07965-1660101 or 07965-1660102 not available in U.S.A.
- Assembly shaft 07965-1660200
  - Assembly collar 07965-1660300 or 07965-1660301 or 07965-1660302 or 07965-166030A (U.S.A. only)

**Right crankcase oil seal:**

- Threaded adapter** 07965-KA30000 or 07VMF-HM8010A
- Threaded adapter, 10 x 12.5 x 16 x 15** 07965-VM00100
- Assembly collar** 07965-VM00200 or 07931-ME4010B and 07931-HB3020A (U.S.A. only)
- Threaded shaft**
- Assembly shaft**
- Special nut**

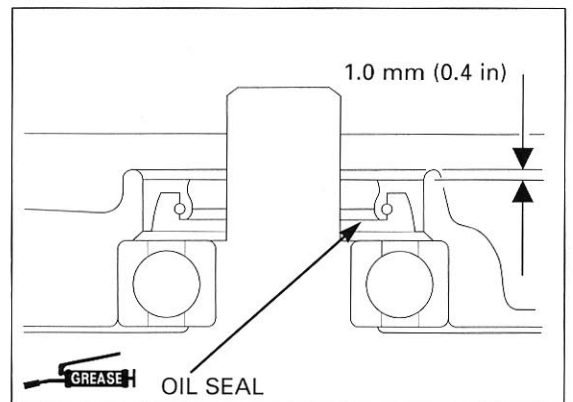
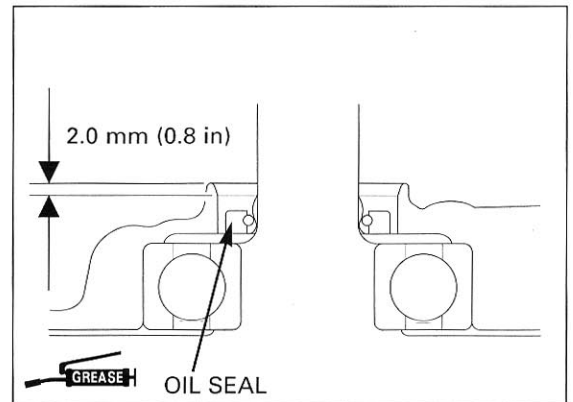
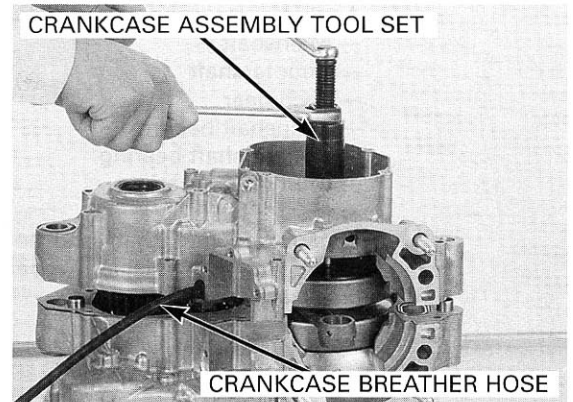
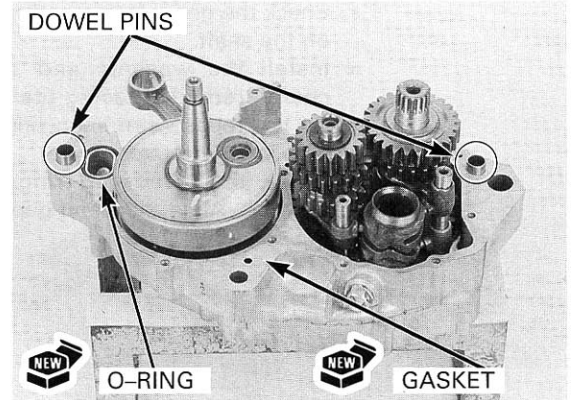



## CRANKCASE/CRANKSHAFT/TRANSMISSION

Tighten the crankcase bolts in a crisscross pattern in two or three progressive steps.

*Do not let gasket material fall into the crankcase. Do not damage the base gasket surface.*

Carefully trim the protruding gasket material from the cylinder base gasket surface.

Check that the crankshaft turns smoothly.

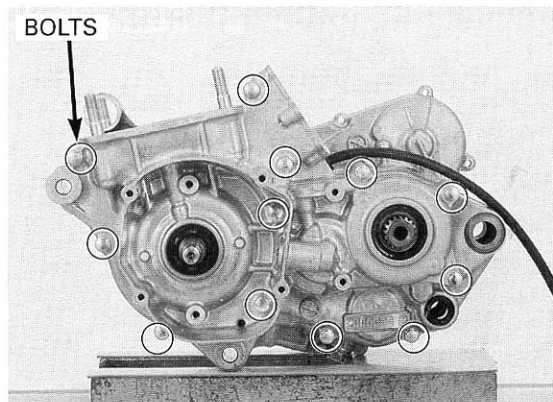

Coat the countershaft O-ring and the inside of the countershaft collar with grease. Install the O-ring and collar onto the countershaft.

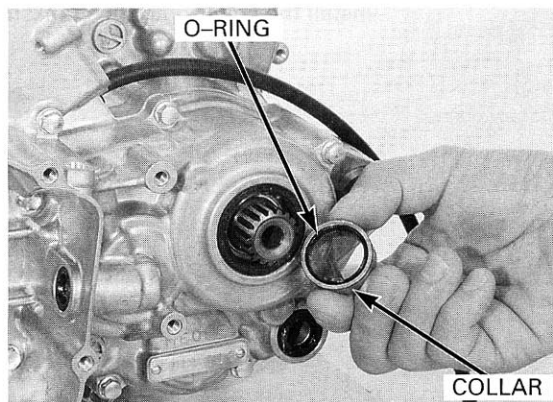

*Install the drive sprocket with its flat side facing out.*

Install the drive sprocket onto the countershaft as described below.

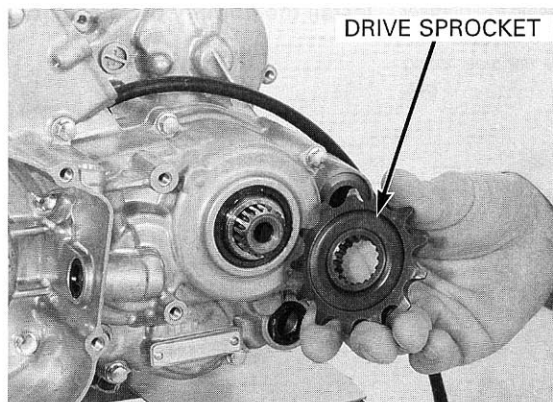

Install the cone spring washer with the "OUT SIDE" mark facing out.

Hold the drive sprocket with the universal holder and install and tighten the sprocket bolt to the specified torque.

### TOOL:

Universal holder

07725-0030000

TORQUE: 26 N·m (2.7 kgf·m, 20 lbf·ft)

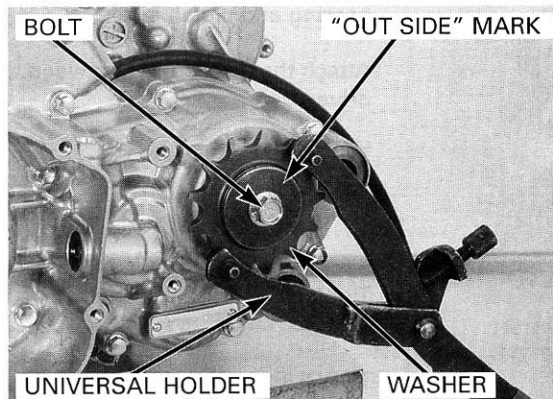

## CRANKCASE/CRANKSHAFT/TRANSMISSION

Install the drive sprocket guard and tighten the bolts.

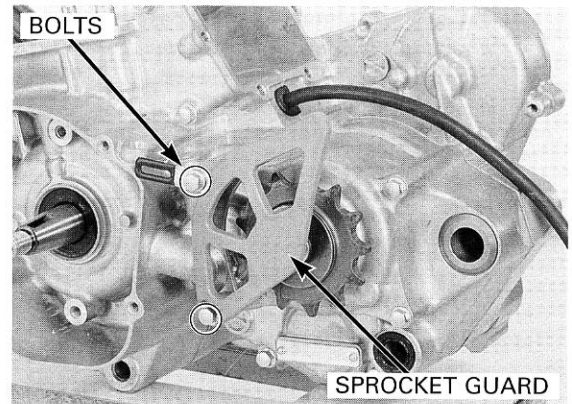

Install the collar onto the crankshaft.

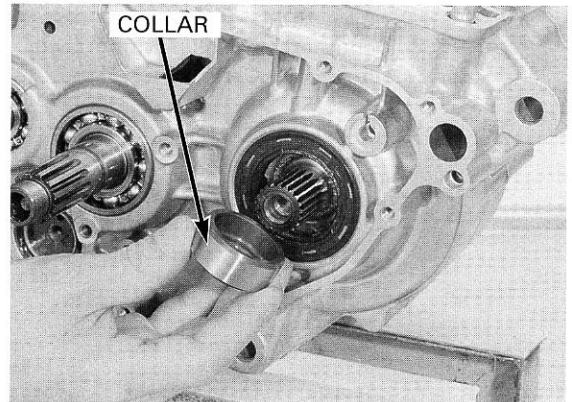

*Install the primary drive gear with the flat side facing out.*

Install the primary drive gear, bolt and washer.

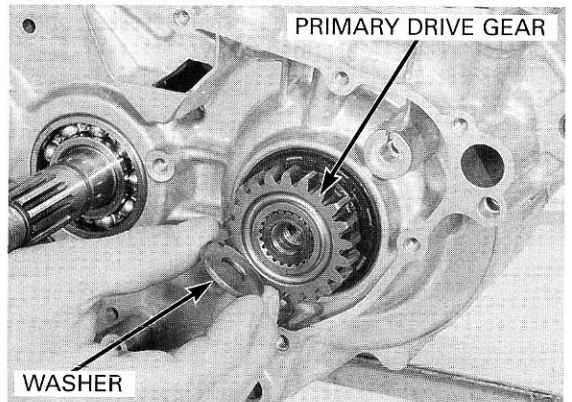

Temporarily install the clutch outer guide, needle bearing and clutch outer.

Attach the gear holder between the primary drive and driven gear.

**TOOL:**  
**Gear holder, 2.5**

**07724-0010100 or**  
**07714-001A100**  
**(U.S.A. only)**

Tighten the primary drive gear bolt to the specified torque.

**TORQUE: 64 N·m (6.5 kgf·m, 47 lbf·ft)**

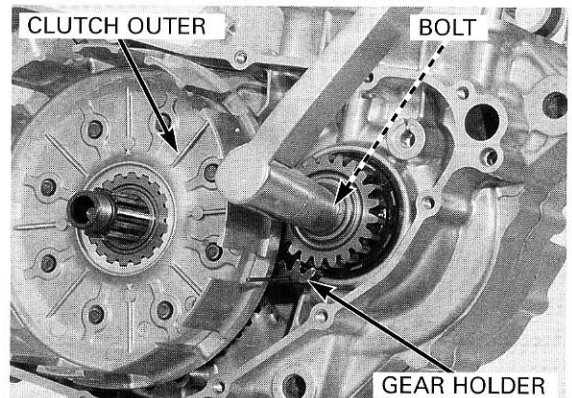

Install the remaining parts in the reverse order of removal.

Refer to Service Information (page 10-1) for installation of parts removed to perform crankcase/transmission service.

Start the engine and check for coolant leaks from the inspection hole.

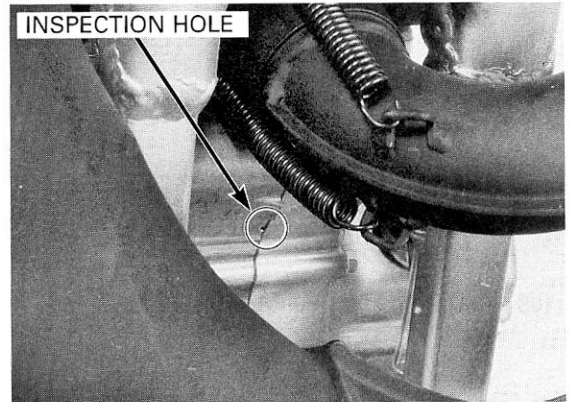

# FRONT WHEEL/SUSPENSION/STEERING

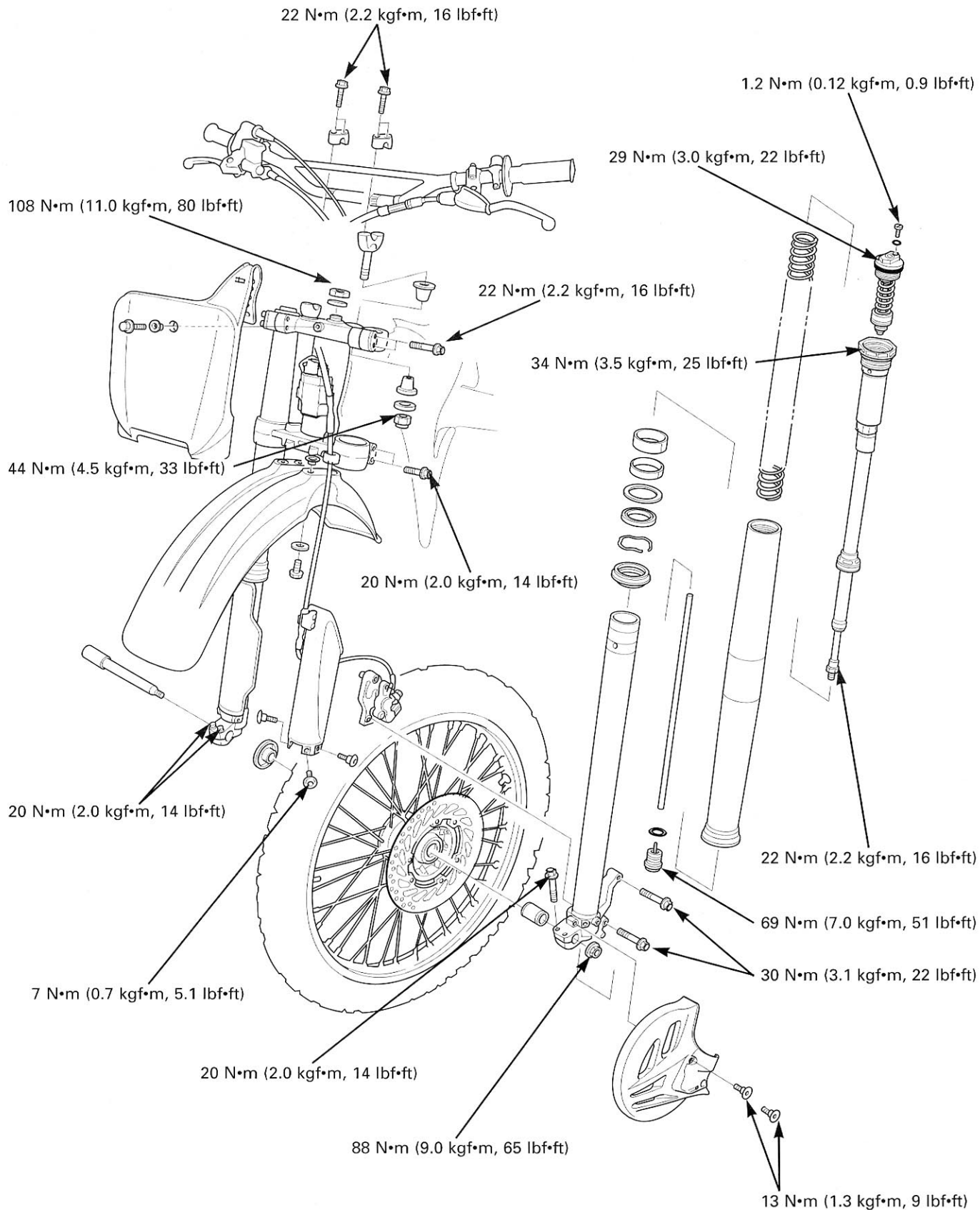

# 11. FRONT WHEEL/SUSPENSION/STEERING

SERVICE INFORMATION	11-1	FORK	11-9
TROUBLESHOOTING	11-3	HANDLEBAR	11-27
FRONT WHEEL	11-4	STEERING STEM	11-33

## SERVICE INFORMATION

### GENERAL

- Brake dust may contain asbestos fibers.
- Never use an air hose or dry brush to clean brake assemblies.
- Keep grease off of brake pads and disc.
- A contaminated brake disc or pad reduces stopping power. Discard contaminated pads and clean a contaminated disc with a high quality brake degreasing agent.
- This section covers maintenance of the front wheel, fork and steering stem.
- When servicing the front wheel, fork or steering stem, support the motorcycle using a safety stand or hoist.
- Optional lighter and heavier than standard springs are available. Refer to General Information, Section 1 for details.
- For optimum performance, the fork should be completely disassembled and cleaned after the first 3 hours of riding. Thereafter it should be disassembled and cleaned on a regular basis to ensure maximum performance and service life for the internal parts.
- Refer to section 13 for brake system information.

### SPECIFICATIONS

Unit: mm (in)

**11**

ITEM		STANDARD	SERVICE LIMIT
Cold tire pressure		100 kPa (1.0 kgf/cm <sup>2</sup> , 15 psi)	—
Axle runout		—	0.20 (0.008)
Wheel rim runout	Radial	—	2.0 (0.08)
	Axial	—	2.0 (0.08)
Wheel hub-to-rim distance		27.25 (1.073)	—
Fork	Spring free length	494 (19.45)	487 (19.17)
	Slider runout	—	0.20 (0.008)
	Recommended fork fluid	Pro Honda HP Fork Oil 5W or equivalent	—
	Fluid capacity	'02	419 cm <sup>3</sup> (14.2 US oz, 14.7 Imp oz)
After '02		405 cm <sup>3</sup> (13.7 US oz, 14.3 Imp oz)	—
Compression damping adjuster standard position	'02	13 clicks out from full in	—
	After '02	14 clicks out from full in	—
Rebound damping adjuster standard position		15 clicks out from full in	—

## FRONT WHEEL/SUSPENSION/STEERING

---

### TORQUE VALUES

Front axle holder bolt		20 N•m (2.0 kgf•m, 14 lbf•ft)
Front axle nut		88 N•m (9.0 kgf•m, 65 lbf•ft)
Front brake disc nut		16 N•m (1.6 kgf•m, 12 lbf•ft)
Front spoke nipple		3.7 N•m (0.38 kgf•m, 2.7 lbf•ft)
Front rim lock		12 N•m (1.2 kgf•m, 9 lbf•ft)
Handlebar upper holder bolt		22 N•m (2.2 kgf•m, 16 lbf•ft)
Handlebar lower holder nut		44 N•m (4.5 kgf•m, 33 lbf•ft) U-nut
Front master cylinder holder bolt		9.9 N•m (1.0 kgf•m, 7 lbf•ft)
Clutch lever holder bolt		9 N•m (0.9 kgf•m, 6.5 lbf•ft)
Clutch lever pivot bolt		2 N•m (0.2 kgf•m, 1.4 lbf•ft)
Clutch lever pivot nut		10 N•m (1.0 kgf•m, 7 lbf•ft)
Throttle housing bolt		9 N•m (0.9 kgf•m, 6.5 lbf•ft)
Throttle housing cover screw		1.5 N•m (0.15 kgf•m, 1.1 lbf•ft)
Engine stop button screw		1.5 N•m (0.15 kgf•m, 1.1 lbf•ft)
Front brake caliper mounting bolt		30 N•m (3.1 kgf•m, 22 lbf•ft) Apply a locking agent to the threads.
Fork cap		29 N•m (3.0 kgf•m, 22 lbf•ft)
Fork center bolt		69 N•m (7.0 kgf•m, 51 lbf•ft)
Fork center lock nut		22 N•m (2.2 kgf•m, 16 lbf•ft)
Plug bolt		1.2 N•m (0.12 kgf•m, 0.9 lbf•ft)
Fork damper		34 N•m (3.5 kgf•m, 25 lbf•ft)
Fork protector mounting bolt		7 N•m (0.7 kgf•m, 5.1 lbf•ft) Apply a locking agent to the threads.
Front brake disc cover bolt		13 N•m (1.3 kgf•m, 9 lbf•ft) Apply a locking agent to the threads.
Fork pinch bolt	(top)	22 N•m (2.2 kgf•m, 16 lbf•ft)
	(bottom)	20 N•m (2.0 kgf•m, 14 lbf•ft)
Steering stem nut		108 N•m (11.0 kgf•m, 80 lbf•ft)
Steering stem adjusting nut		7 N•m (0.7 kgf•m, 5.1 lbf•ft)
Brake hose guide bolt		5.2 N•m (0.53 kgf•m, 3.8 lbf•ft)

### TOOLS

Extension bar	07716-0020500 or equivalent commercially available in U.S.A.
Attachment, 37 x 40 mm	07746-0010200
Pilot, 20 mm	07746-0040500
Attachment, 30 mm I.D.	07746-0030300
Bearing remover shaft	07746-0050100
Bearing remover head, 20 mm	07746-0050600
Driver	07749-0010000
Steering stem socket	07916-3710101 or 07916-3710100 or 07702-0020001
Ball race remover	07946-3710500
Piston base	07958-2500001
Spoke nipple wrench	07JMA-MR60100 or equivalent commercially available in U.S.A.
Fork seal driver, 47 mm	07VMD-KZ30100 or 07VMD-KZ3010A (U.S.A. only)
Bearing race installer	07VMF-KZ30100
Installer shaft	07VMF-KZ30200
Lock nut wrench, 50 mm	07WMF-KZ30100

## TROUBLESHOOTING

### Hard steering

- Steering adjusting nut too tight
- Faulty or damaged steering head bearings
- Insufficient tire pressure

### Steers to one side or does not track straight

- Bent fork pipe
- Bent axle
- Wheel installed incorrectly
- Unequal oil quantity in each fork pipe
- Faulty steering head bearings
- Bent frame
- Worn wheel bearing
- Worn swingarm pivot components
- Unevenly adjusted right and left fork legs

### Front wheel wobbles

- Bent rim
- Worn front wheel bearings
- Bent spokes
- Faulty tire
- Axle not tightened properly
- Unbalanced tire and wheel

### Wheel turns hard

- Faulty wheel bearing
- Bent front axle
- Brake drag

### Soft suspension

- Insufficient fluid in fork
- Fork oil viscosity too thin
- Weak fork springs
- Tire pressure too low

### Hard suspension

- Fork oil level too much
- Fork oil viscosity too thick
- Bent or damage fork pipes
- Clogged fork fluid passage

### Front suspension noisy

- Insufficient fluid in fork
- Loose fork fasteners

### FRONT WHEEL

#### REMOVAL

Remove the bolts and front brake disc cover.

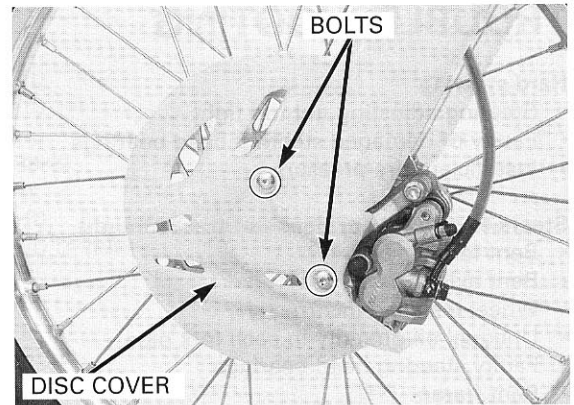

Support the motorcycle using a safety stand or hoist under the engine.

Remove the axle nut.

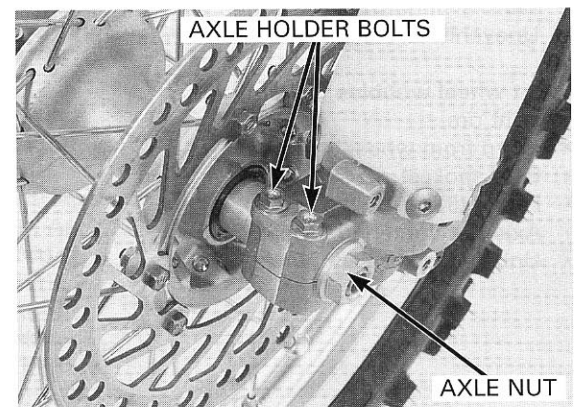

Remove the axle pinch bolts and pull out the axle.

Remove the front wheel assembly.

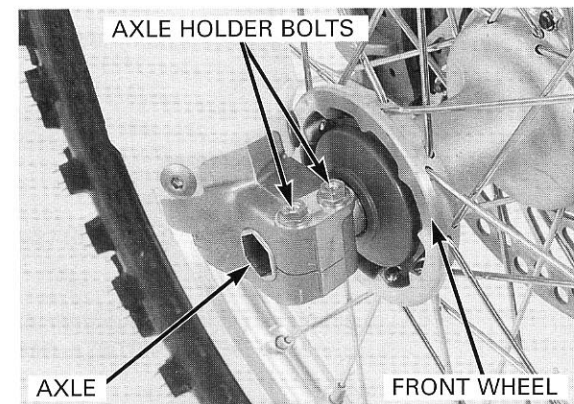

#### INSPECTION

##### AXLE

Set the axle in V-blocks and measure the runout. Turn the axle and measure the runout using a dial indicator.

Actual runout is 1/2 the total indicator reading.

**SERVICE LIMIT: 0.2 mm (0.008 in)**

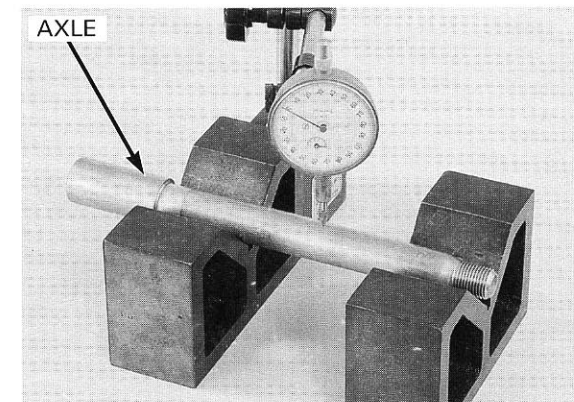



### WHEEL BEARING

Turn the inner race of each bearing with your finger. The bearings should turn smoothly and quietly. Also check that the bearing outer race fits tightly in the hub.

*Replace the bearings in pairs.*

Remove and discard the bearings if the races do not turn smoothly, quietly, or if they fit loosely in the hub.

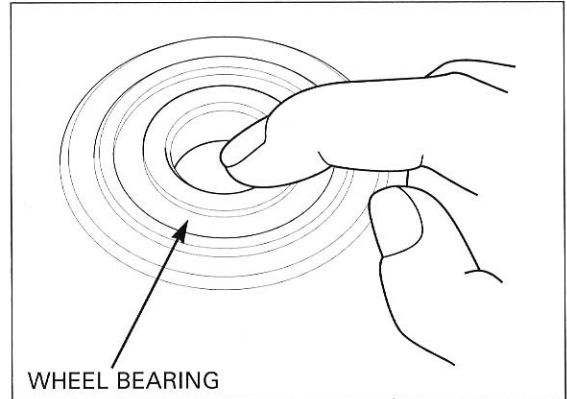

### WHEEL RIM

Check the rim runout by placing the wheel on a truing stand. Then rotate the wheel by hand and read the runout using a dial indicator. Actual runout is 1/2 the total indicated reading.

**SERVICE LIMITS: Radial: 2.0 mm (0.08 in)**  
**Axial: 2.0 mm (0.08 in)**

Check the spokes and tighten any distance collar.

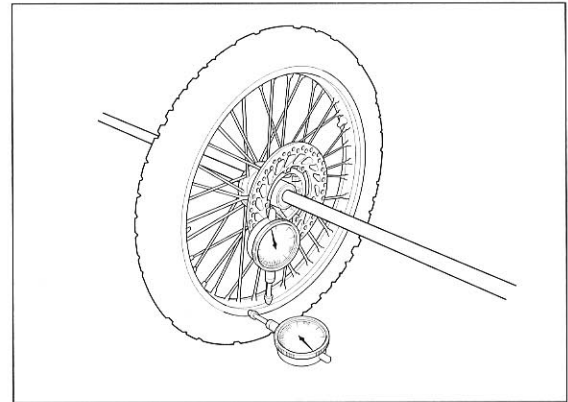

### DISASSEMBLY

Remove the right side collar and dust seal.

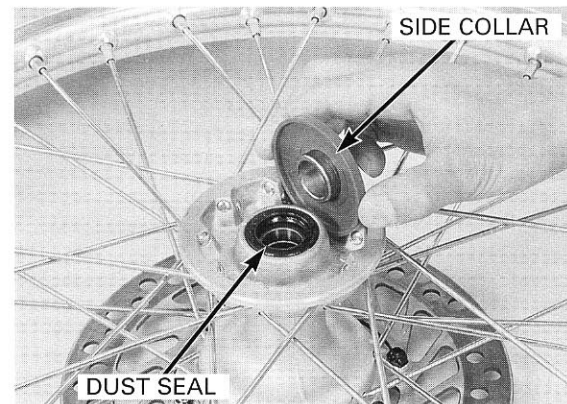

Remove the left side collar and dust seal.  
Remove the brake disc bolts and nuts.  
Remove the brake disc.

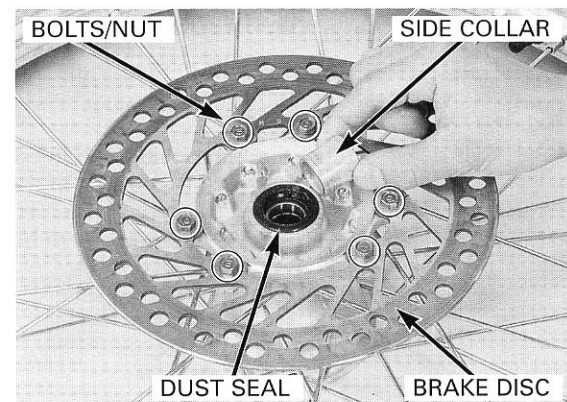

## FRONT WHEEL/SUSPENSION/STEERING

Remove the wheel bearings and distance collar.

### TOOLS:

Bearing remover head, 20 mm 07746-0050600

Bearing remover shaft 07746-0050100

- Never reinstall old bearings; once the bearings have been removed, they must be replaced with new ones.
- Replace the bearings in pairs.

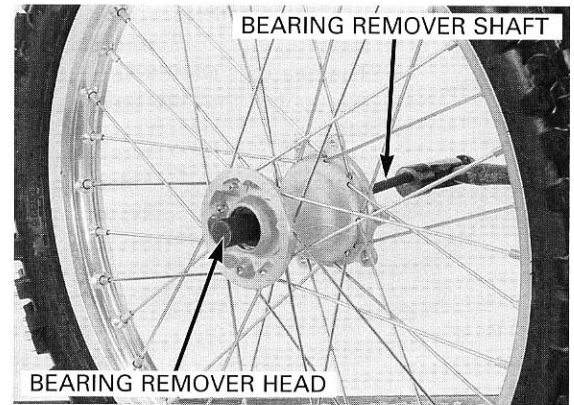

## ASSEMBLY

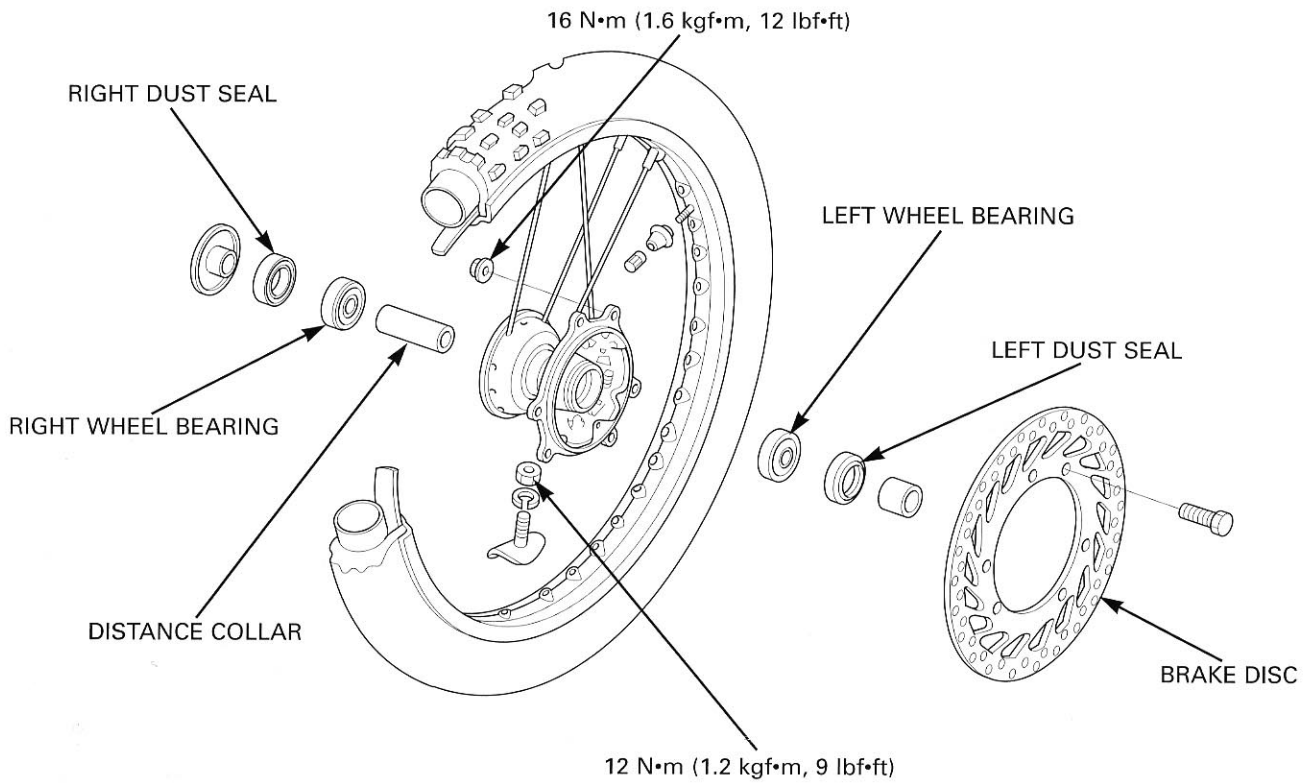

Place the wheel rim on a work bench.

Place the hub with the disc side down and begin lacing with new spokes.

Adjust the hub position so the distance from the hub left end surface to the side of the rim is as shown.

**STANDARD: 27.25 mm (1.073 in)**

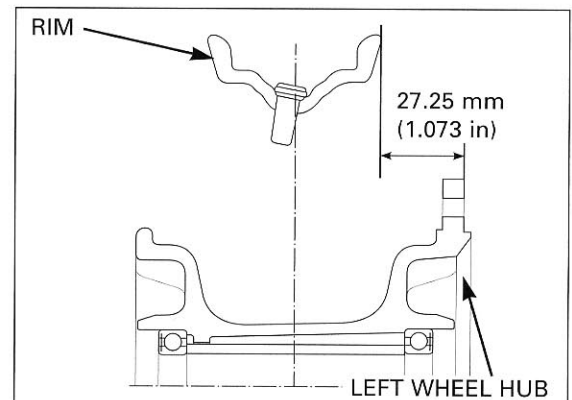

## FRONT WHEEL/SUSPENSION/STEERING

Torque the spokes in two or three progressive steps.

**TOOL:**

**Spoke nipple wrench**      **07JMA-MR60100 or  
equivalent commercially  
available in U.S.A.**

**TORQUE: 3.7 N·m (0.38 kgf·m, 2.7 lbf·ft)**

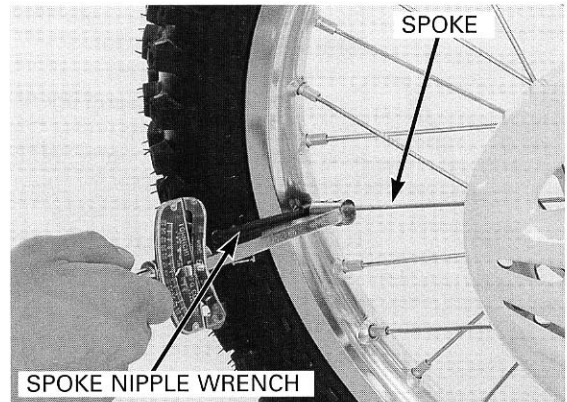

Install the rim lock, rim band, tube and tire.

Torque the rim lock to the specified torque.

**TORQUE: 12 N·m (1.2 kgf·m, 9 lbf·ft)**

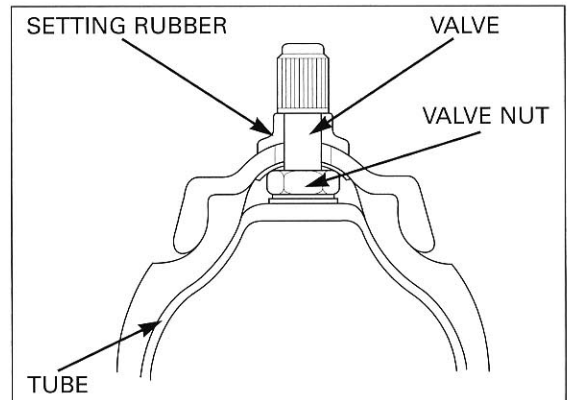

Pack all bearing cavities with grease.

Drive the left wheel bearing into the hub using the special tools as shown.

**TOOLS:**

<b>Driver</b>	<b>07749-0010000</b>
<b>Attachment, 37 x 40 mm</b>	<b>07746-0010200</b>
<b>Pilot, 20 mm</b>	<b>07746-0040500</b>

Install the distance collar into place, then drive the right wheel bearing using the same special tools.

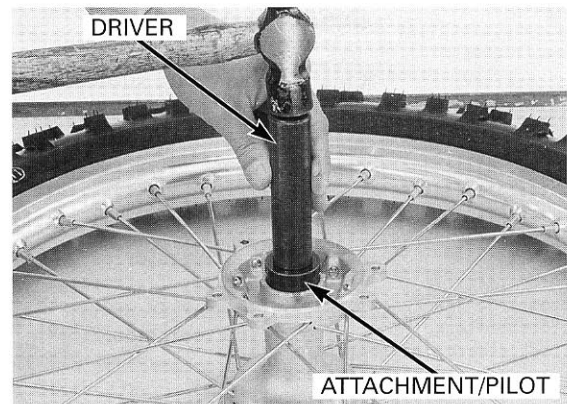

Pack the right dust seal lip with grease and install the right dust seal.

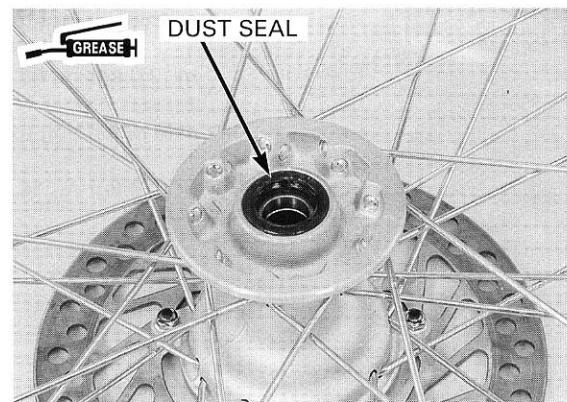

## FRONT WHEEL/SUSPENSION/STEERING

Install the brake disc onto the wheel hub with the "DRIVE" mark facing out.

Clean and apply a locking agent to the brake disc bolt threads.

Install the brake disc bolts and nuts.  
Tighten the nuts to the specified torque.

**TORQUE: 16 N·m (1.6 kgf·m, 12 lbf·ft)**

Pack the left dust seal lip with the grease and install the left dust seal.

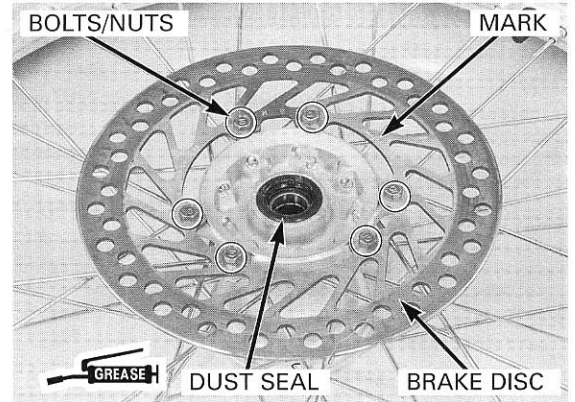

Check the right and left wheel collar for wear or damage.

Install the right and left wheel collar to the wheel.

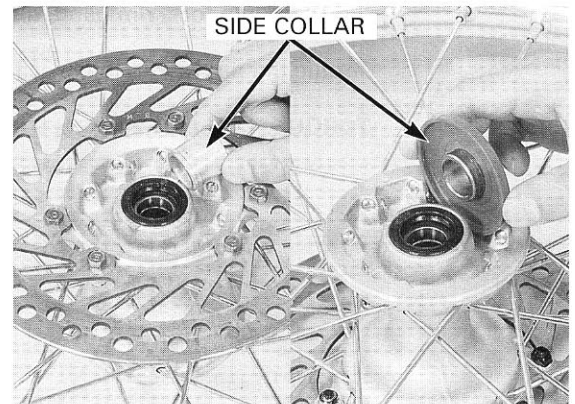

## INSTALLATION

Clean the clamping surface of the axle shaft and axle holders.

Install the front wheel between the fork legs.

Fit the caliper over the disc, taking care not to damage the brake pads.

Apply a thin layer of grease to the axle and insert the axle from the right side.

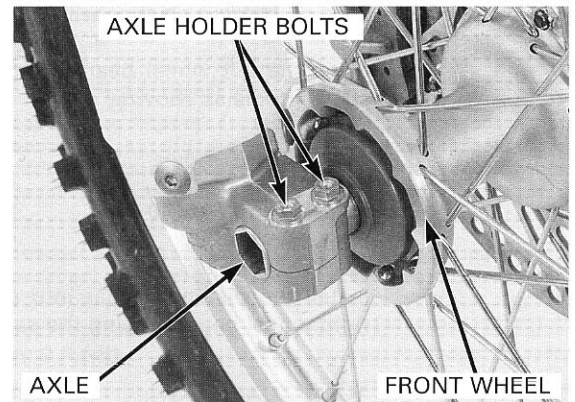

Install and tighten the axle nut to the specified torque.

**TORQUE: 88 N·m (9.0 kgf·m, 65 lbf·ft)**

Tighten the left axle pinch bolt to the specified torque.

**TORQUE: 20 N·m (2.0 kgf·m, 14 lbf·ft)**

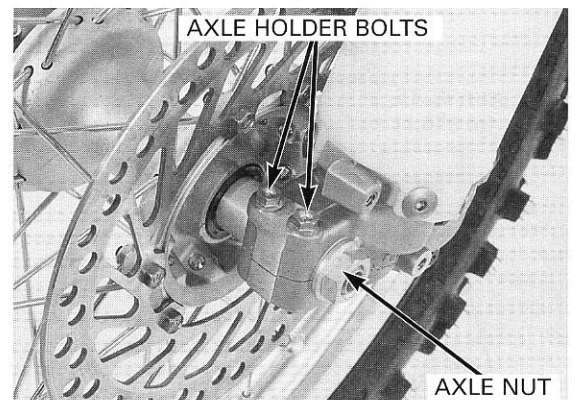

With the front brake applied, pump the front suspension up and down several times to seat the axle and check front brake operation.

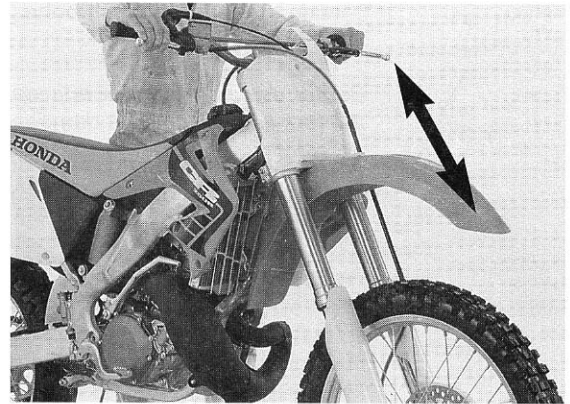

Be sure the fork legs are parallel, then tighten the right axle pinch bolts to the specified torque.

**TORQUE: 20 N·m (2.0 kgf·m, 14 lbf·ft)**

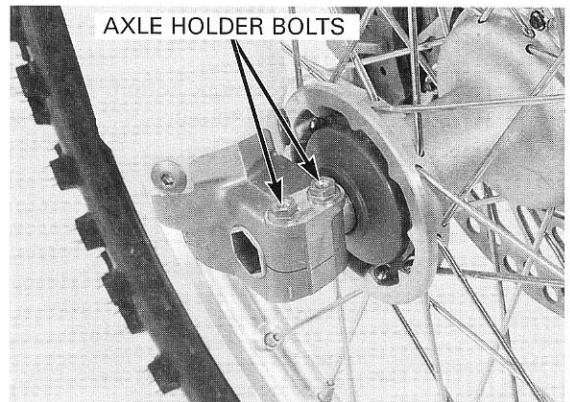

Install the front brake disc cover.  
Clean and apply a locking agent to the brake disc cover bolt threads.  
Install and tighten the front brake disc cover bolts to the specified torque.

**TORQUE: 13 N·m (1.3 kgf·m, 9 lbf·ft)**

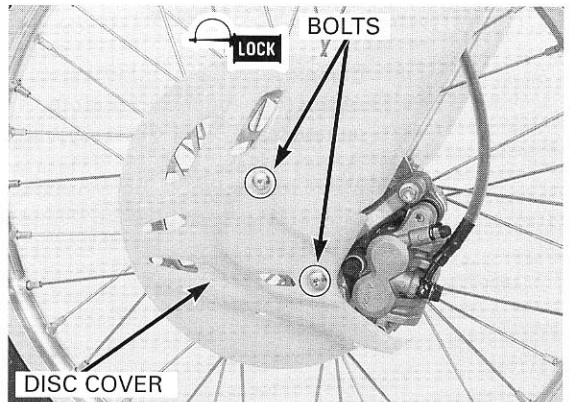

## **FORK**

### **REMOVAL**

*Do not suspend the brake caliper from the brake hose.  
Do not twist the brake hose.*

Remove the front wheel (page 11-4).  
Remove the brake caliper (page 13-15).

Do not operate the brake lever after removing the caliper and front wheel. To do so will cause difficulty in fitting the brake disc between the brake pad.  
Remove the bolts and brake hose clamp.

Remove the bolts and fork protector.

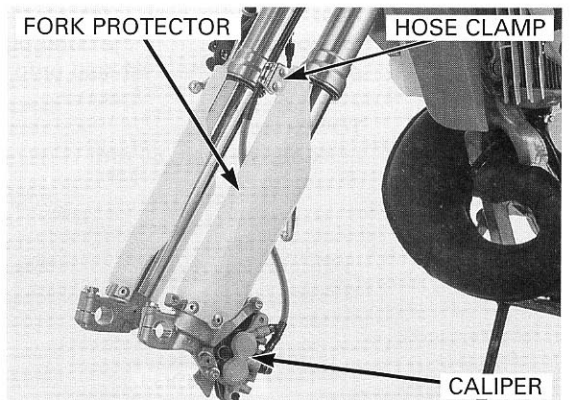

## FRONT WHEEL/SUSPENSION/STEERING

Loosen the fork top pinch bolts.

### NOTICE

*Do not use a crescent or adjustable wrench to loosen the fork cap; it could be damaged.*

When the fork is ready to be disassembled, remove the handlebar and holders (page 11-27) and loosen the fork damper cap, but do not remove it.

When disassembling the fork leg, turn the rebound and compression adjusters counterclockwise to the softest position to prevent damage to the adjustment needles (be sure to record the number of turns from the starting position).

### TOOL:

**Lock nut wrench, 50 mm      07WMA-KZ30100**

Loosen the fork bottom pinch bolts and pull the fork leg down and out.

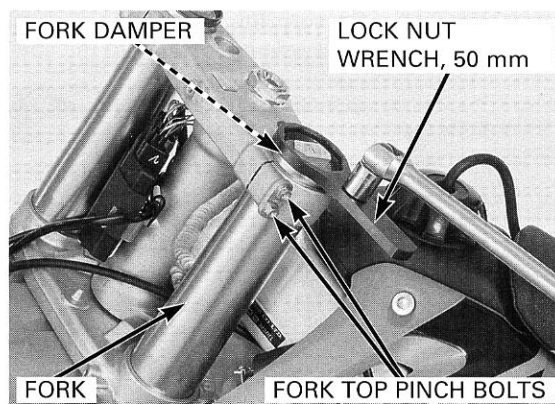
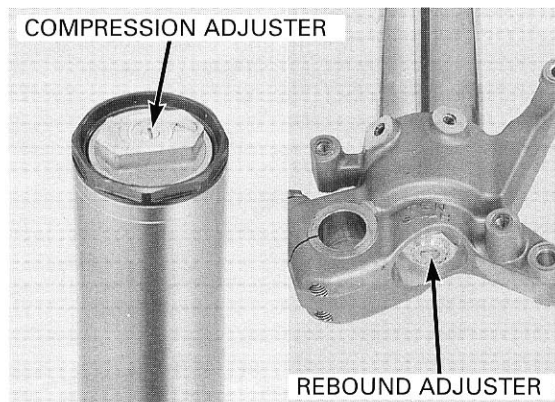

## DISASSEMBLY

*Be careful not to scratch the slider and not to damage the dust seal.*

Clean the fork assembly, especially the sliding surface of the fork slider and bottom of the slider around the center bolt before disassembling the fork.

Measure the length between the axle holder and outer pipe and record it before disassembling the fork.

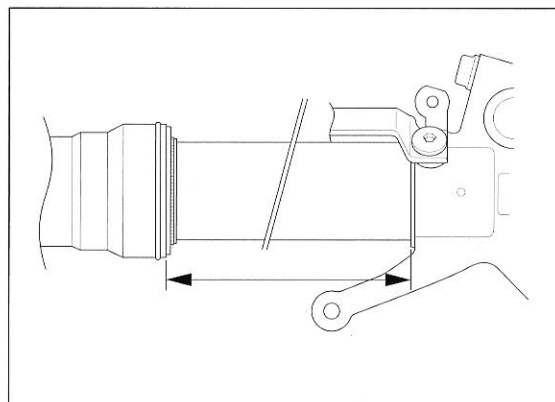

Hold the outer pipe, remove the fork damper using the special tool from the outer pipe and slide the outer pipe down to the dust seal onto the axle holder.

### TOOL:

**Lock nut wrench, 50 mm      07WMA-KZ30100**

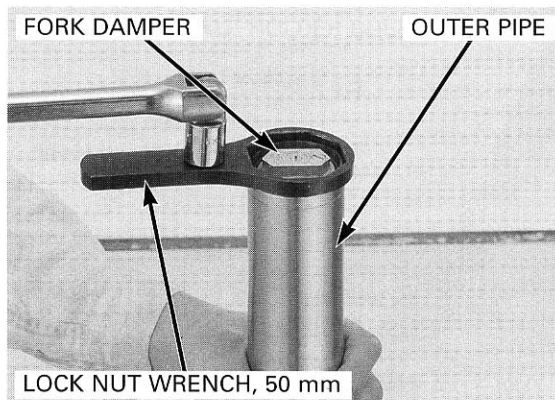

Drain the fork oil from the fork leg.  
Drain the fork oil from the hole of the fork damper.

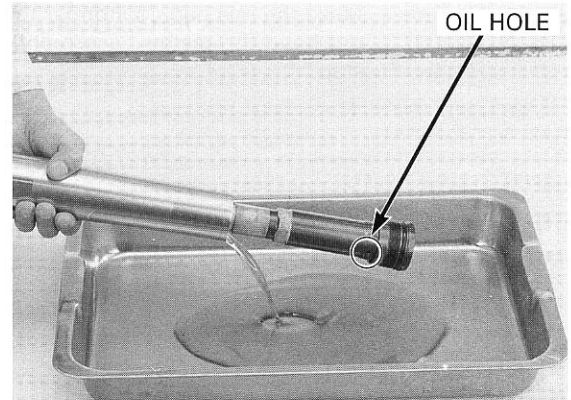

Temporarily install the fork damper to the outer pipe.

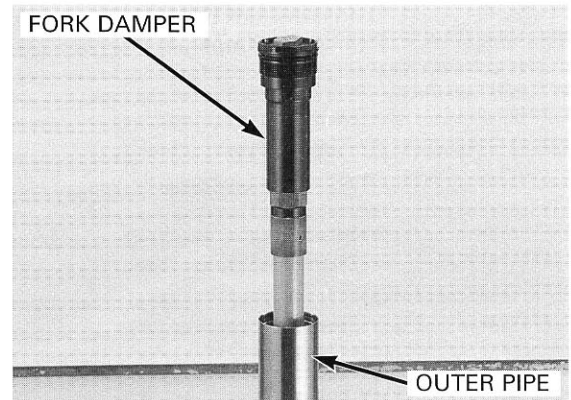

*Do not clamp the brake caliper hanger too tight.*

Set the lower end (axle holder) of the slider in a vise with a piece of wood or soft jaws to avoid damage.

Loosen the center bolt.

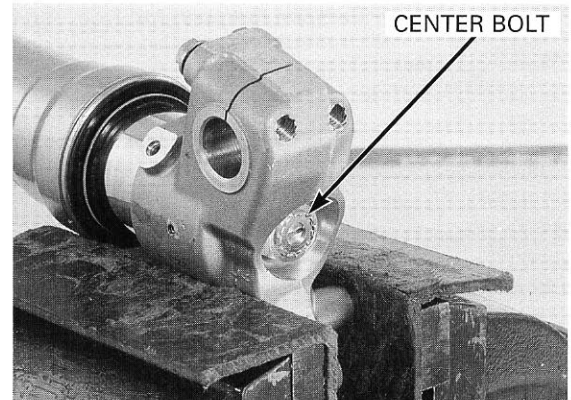

*If the piston base is not available, refer to the next page to make an alternative tool.*

Push out the fork center bolt from the axle holder of the slider by pushing the fork cap.

While the center bolt is pushed out, install the special tool between the axle holder and lock nut.

**TOOL:**  
**Piston base**

**07958-250001**

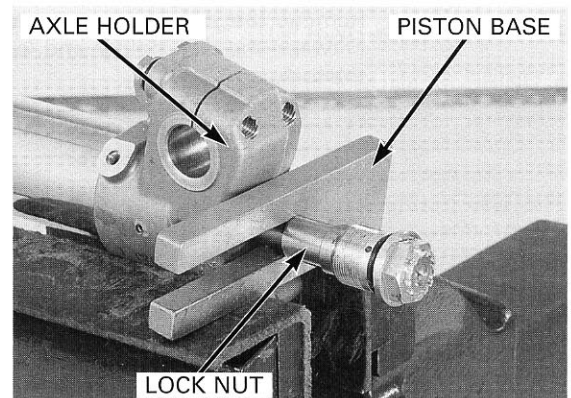

## FRONT WHEEL/SUSPENSION/STEERING

Make the mechanic's stopper tool as shown if you do not have the piston base mentioned in the previous step.

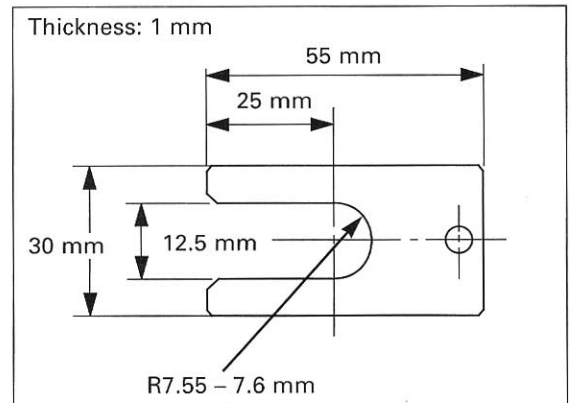

*Do not remove the lock nut from the fork damper piston rod. If the lock nut is removed, the piston rod will fall into the fork damper and you will not be able to reassemble the fork damper.*

Hold the lock nut and remove the fork center bolt from the fork damper.

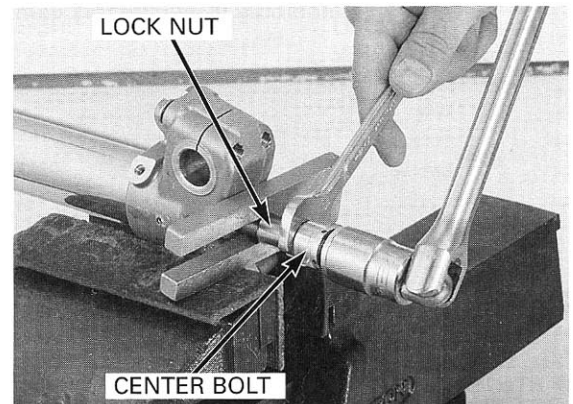

Remove the push rod from the fork damper.

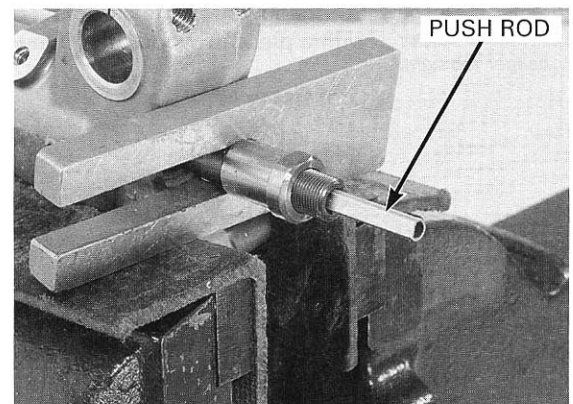

*Be careful not to damage the lock nut and fork center bolt hole.*

Remove the special tool or mechanic's stopper tool between the axle holder and lock nut while pushing the fork cap.

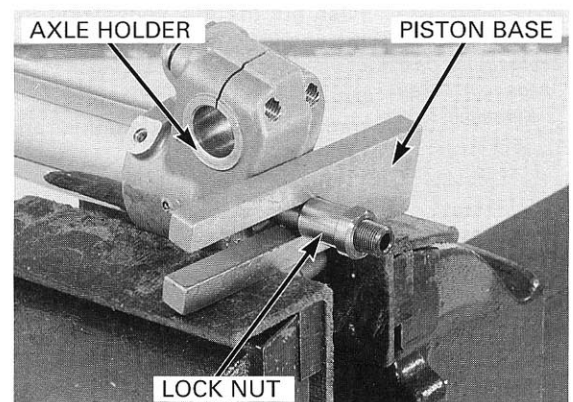



Remove the fork cap from the outer pipe and fork damper from the fork.  
Remove the fork from the vise.  
Remove the fork spring from the fork.

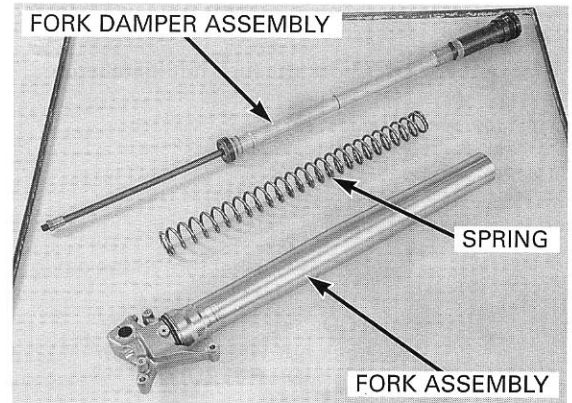

### OUTER PIPE AND SLIDER DISASSEMBLY

*Be careful not to scratch the slider.*

Remove the dust seal and stop ring.

Check that the slider moves smoothly in the outer pipe.

If it does not, check the slider for bends or damage, and the bushings for wear or damage (page 11-16).

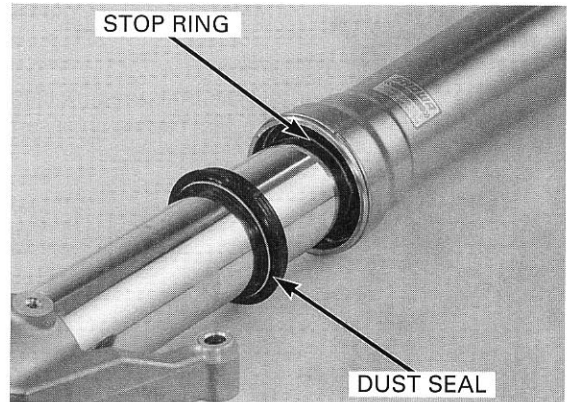

In quick successive motions, pull the slider out of the outer pipe.

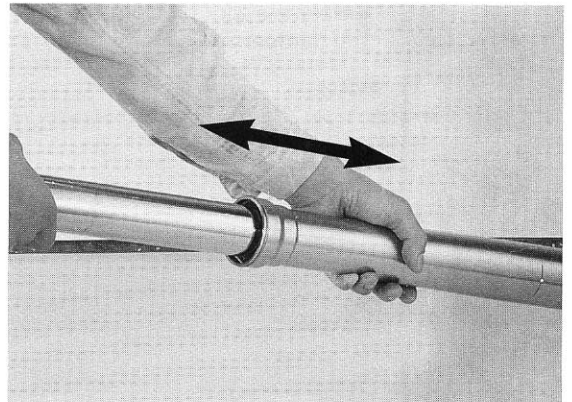

*Do not damage the slider bushing, especially the sliding surface. To prevent loss of tension, do not open the bushing more than necessary.*

Carefully remove the slider bushing by prying the slot with a screwdriver until the bushing can be pulled off by hand.

Remove the guide bushing, back-up ring, oil seal, stop ring and dust seal from the slider.

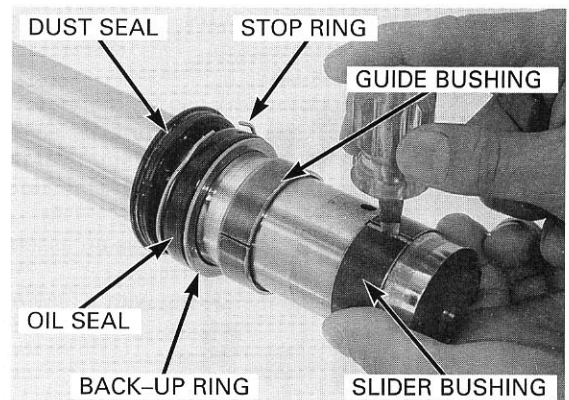

## FRONT WHEEL/SUSPENSION/STEERING

### FORK DAMPER DISASSEMBLY

*If the lock nut is removed, the piston rod will fall into the fork damper and you will not be able to reassemble the fork damper.*

Check the lock nut installation.

Set the special tool to the cut-outs in the fork damper.

#### TOOL:

Lock nut wrench, 50 mm      07WMA-KZ30100

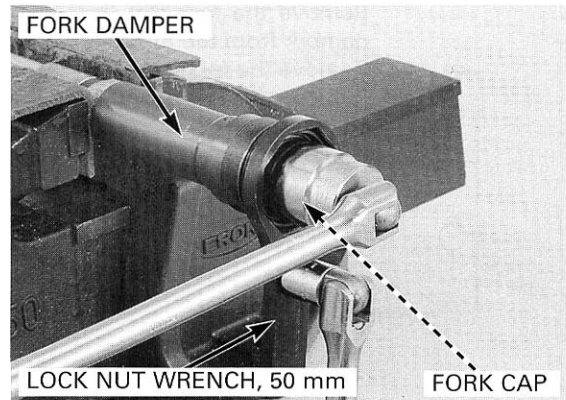

*Be careful not to damage the fork cap bushing.*

Remove the fork cap from the fork damper.

Do not disassemble the fork cap assembly.  
Replace the fork cap as an assembly if it is damaged.

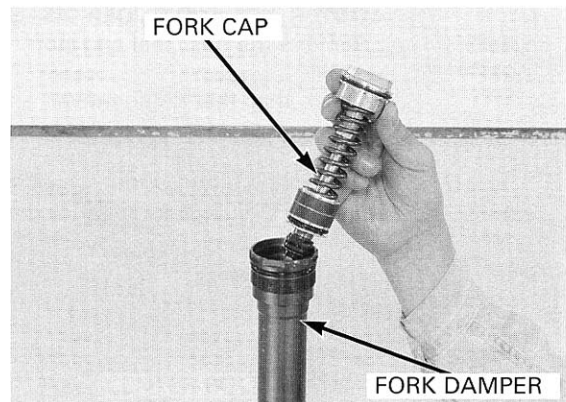

Empty the fork oil from the fork damper by pumping the damper rod several times.

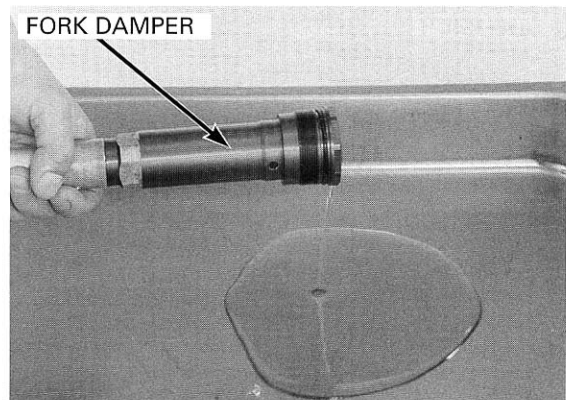

### INSPECTION

#### FORK CAP

Check the fork cap for damage.  
Check the bushing for excessive wear or scratches.  
Check the spring for fatigue or damage.  
Check the compression adjuster for clicks.

Replace the fork cap as an assembly if necessary.

Replace the O-ring with a new one.

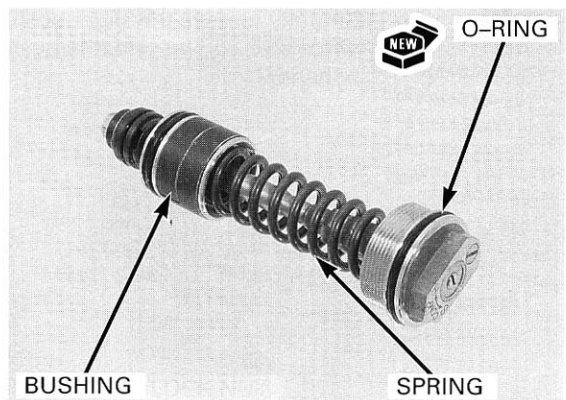

### FORK CENTER BOLT

Check the fork center bolt for damage.  
Check the adjuster rod for stepped wear or damage.  
Check the rebound adjuster for clicks.

Replace the fork center bolt as an assembly if necessary.

Replace the O-ring with a new one.

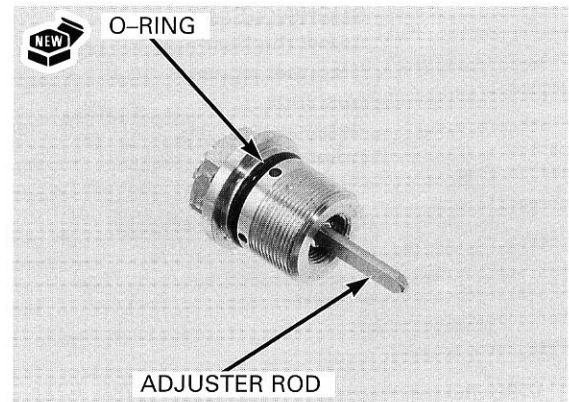

### SLIDER/OUTER PIPE

Check the slider and outer pipe for score marks, scratches and excessive or abnormal wear.  
Check the outer pipe for damage or bends.

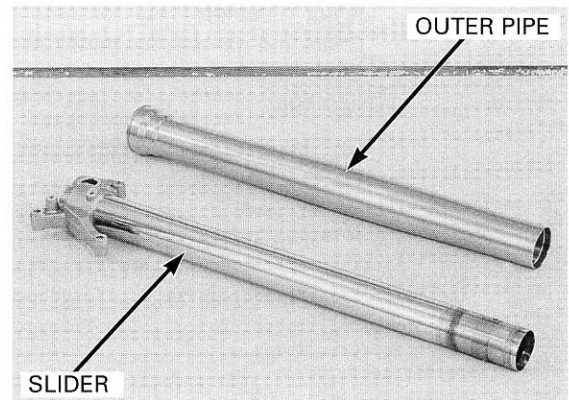

Set the slider in V-blocks and measure the slider runout by rotating it with a dial indicator.  
Actual runout is 1/2 the total indicator reading.

**SERVICE LIMIT: 0.20 mm (0.008 in)**

*Do not reuse the slider if it is bent.*

Replace if the service limit is exceeded, or there are scratches or nicks that will allow fork oil to leak past the seals.

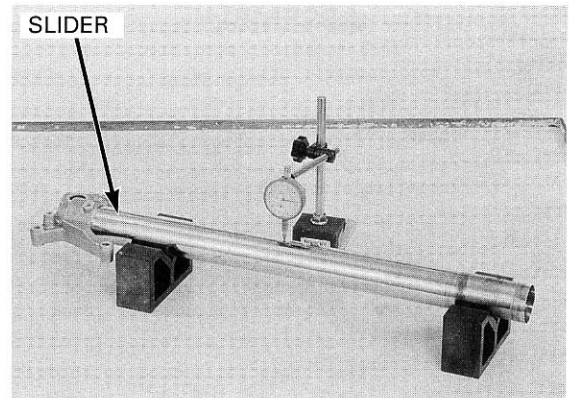

### FORK SPRING

Measure the fork spring free length by placing it on a flat surface.

**SERVICE LIMIT: 487 mm (19.17 in)**

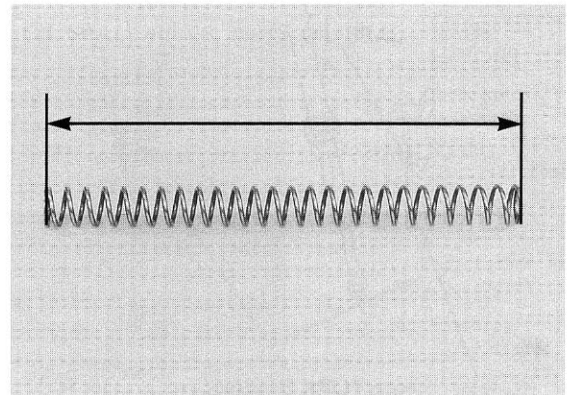

## FRONT WHEEL/SUSPENSION/STEERING

### BUSHING/BACK-UP RING

Check the bushings for excessive wear or scratches. If copper appears on the entire surface, replace the bushings.

Replace the back-up ring if there is distortion at the points shown.

Remove any metal powder from the slider and guide bushings with a nylon brush and fork oil.

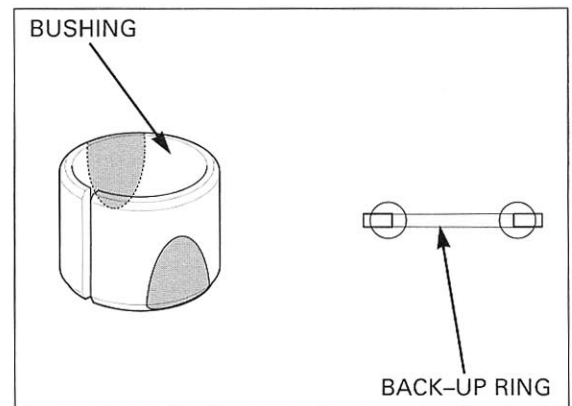

### FORK DAMPER

Check the damper for bends or damage.

Check the fork damper piston rod for bends, wear or damage.

Check the fork damper operation by pumping the piston rod.

If the operation is not smooth, fill the fork damper with fork oil and check the fork damper operation again (page 11-21).

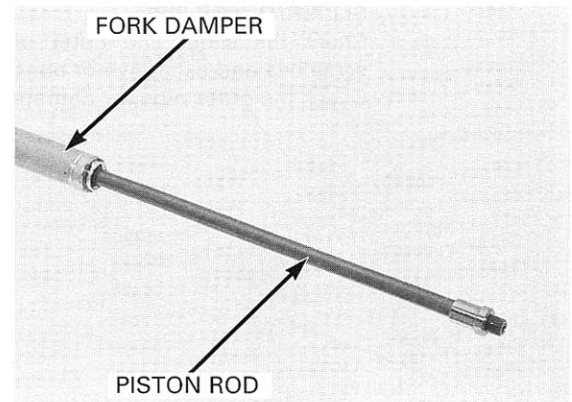

### ASSEMBLY

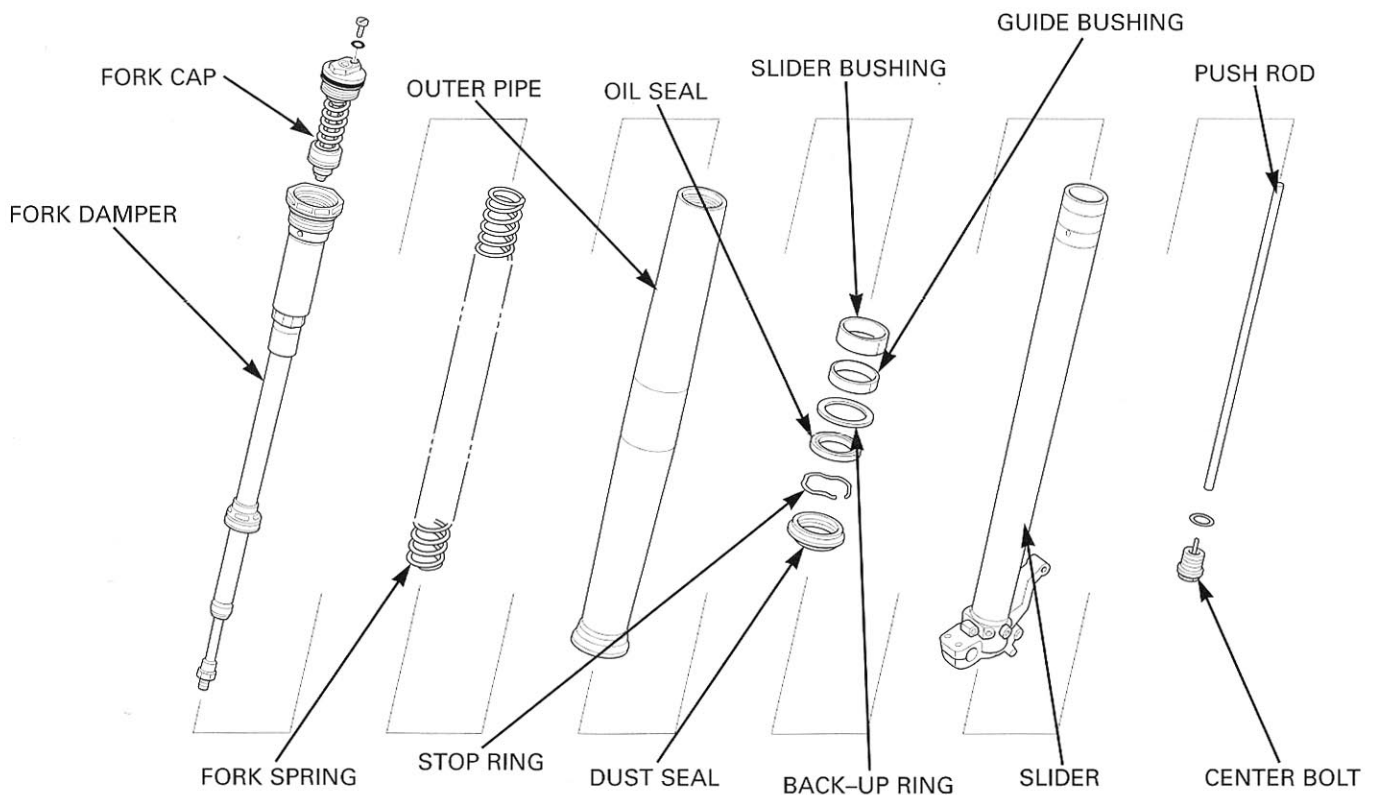

Clean the disassembled parts thoroughly with non-flammable or high flash-point solvent and wipe them off completely before assembly.

**OUTER PIPE AND SLIDER ASSEMBLY**

Wrap the end of the slider with tape.  
Coat the new oil seal lips with fork oil.

Install the dust seal and stop ring onto the slider.  
Install the oil seal onto the slider with its marked side facing the dust seal.

Remove the tape from the end of the slider.

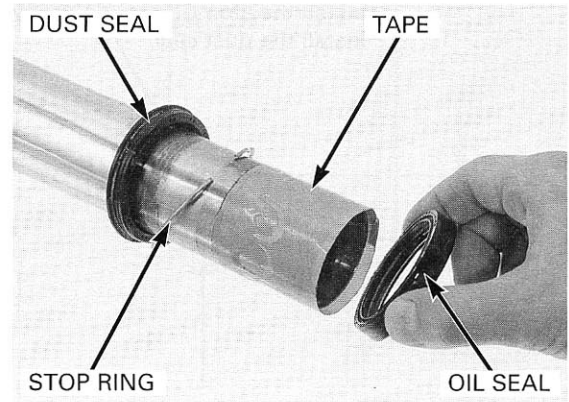

Remove any burrs from the bushing, taking care not to peel off its coating.

*Be careful not to damage the slider bushing.  
Do not open the slider bushing more than necessary.*

Install the back-up ring, guide bushing and slider bushing onto the slider.

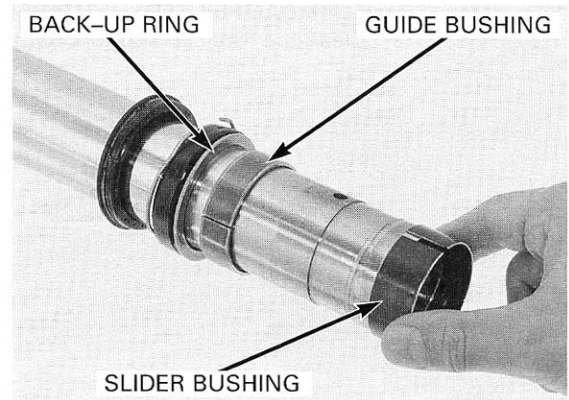

Coat the slider and guide bushings with the recommended fork oil and install the slider into the outer pipe.

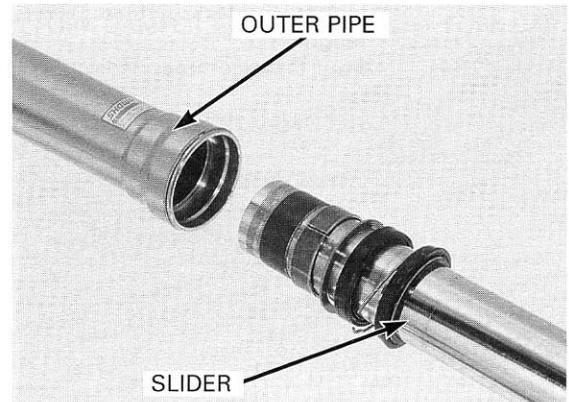

Drive in the guide bushing together with the back-up ring into the outer pipe, using the special tool.  
Next, drive the oil seal into the outer pipe using the special tool.

**TOOL:**  
Fork seal driver

**07VMD-KZ30100 or  
07VMD-KZ3010A  
(U.S.A. only)**

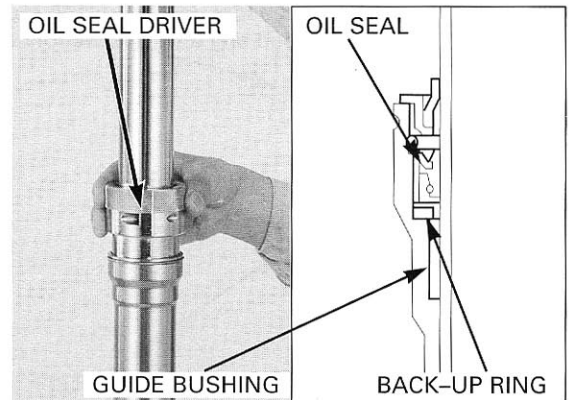

## FRONT WHEEL/SUSPENSION/STEERING

Install the stop ring to the groove in the slider.  
Install the dust seal.

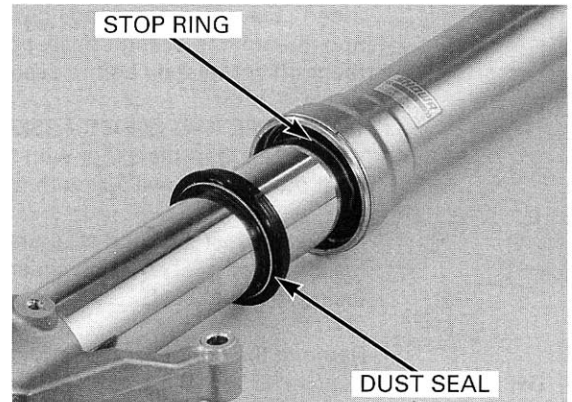

### FORK DAMPER REFILLING/ASSEMBLY

Clean the fork cap and fork damper threads.

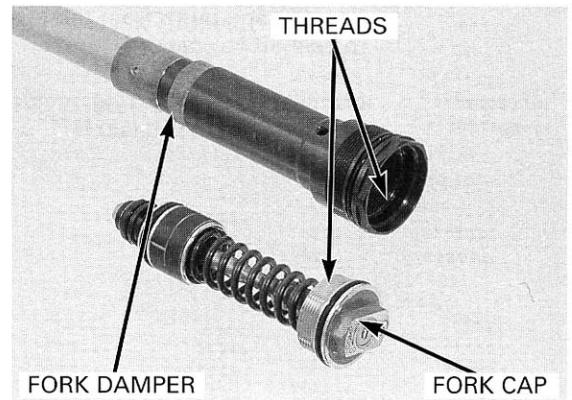

Extend the fork damper piston rod to its maximum length.  
Pour the recommended fork oil into the fork damper.

**RECOMMENDED FORK OIL: Pro Honda HP Fork Oil  
5W or equivalent**

#### STANDARD QUANTITY:

'02: 185 cm<sup>3</sup> (6.3 oz)

After '02: 195 cm<sup>3</sup> (6.6 oz)

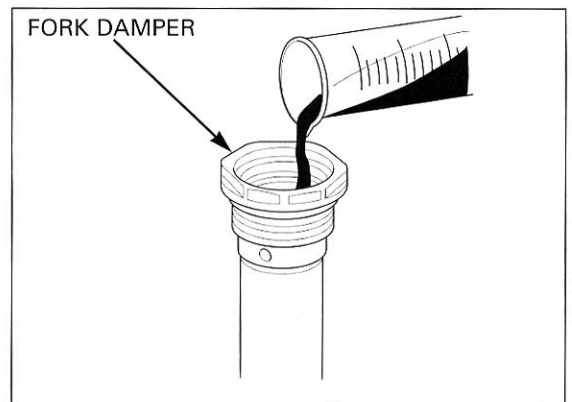

Pump the fork damper piston rod slowly several times  
and bleed any air from the fork damper.

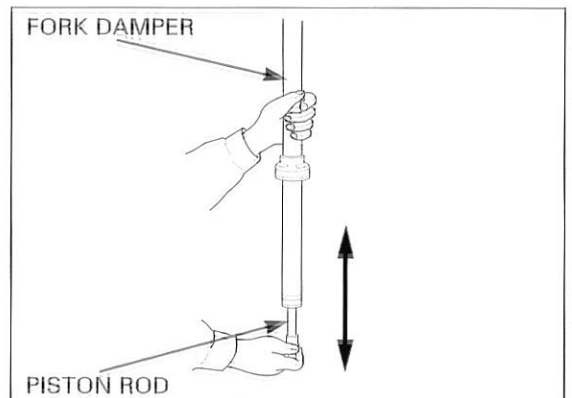

## FRONT WHEEL/SUSPENSION/STEERING

Extend the fork damper piston rod to its maximum length.  
Adjust the oil level of the fork damper as shown.

### OIL LEVEL:

'02: 5 – 10 mm (0.2 – 0.4 in)

After '02: 42 – 47 mm (1.65 – 1.85 in)

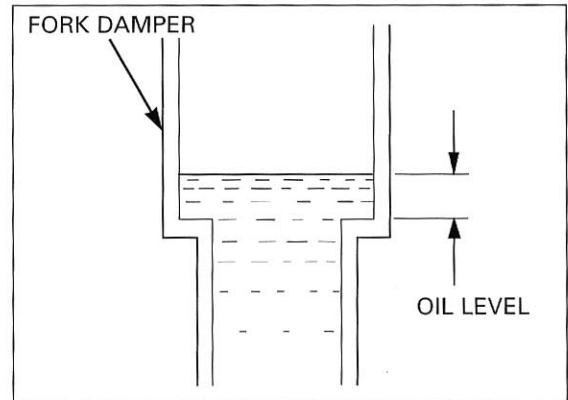

*Be careful not to damage the fork cap bushing.*

Apply fork oil to the bushing and new O-ring on the fork cap assembly.  
Extend the fork damper piston rod to maximum. Hold the rod and install the fork cap assembly to the fork damper.

If it is difficult to install the fork cap assembly, the fork damper oil level might be higher than standard. Inspect the fork damper oil level again.

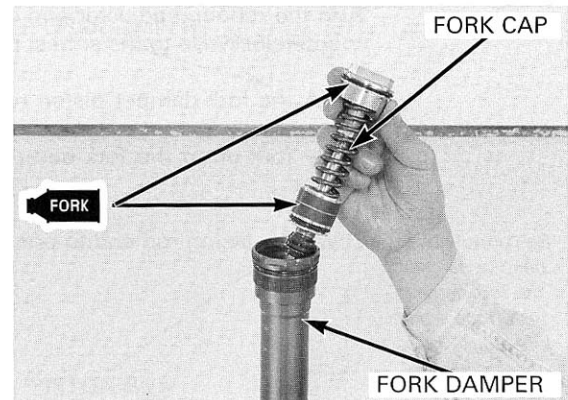

Tighten the fork cap by holding the fork damper using the special tool.

### TOOL:

Lock nut wrench, 50 mm 07WMA-KZ30100

TORQUE: 29 N·m (3.0 kgf·m, 22 lbf·ft)

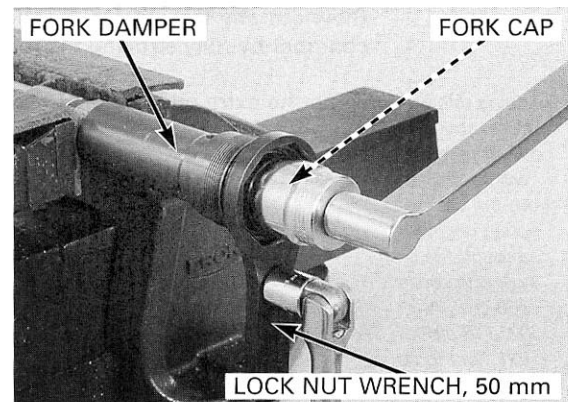

Hold the fork damper in an upright position and pump the fork piston rod to 100 mm (3.9 in) slowly, several times.

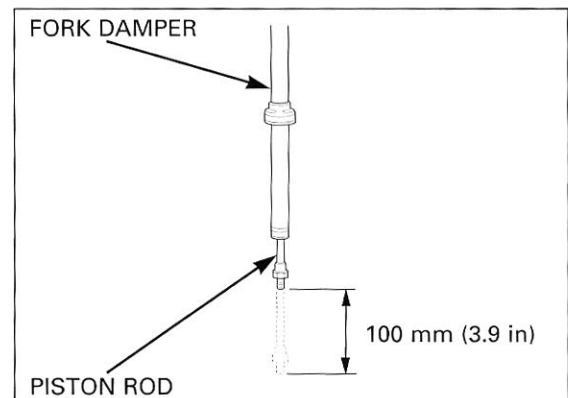

## FRONT WHEEL/SUSPENSION/STEERING

Turn the lock nut onto the fork damper piston rod until fully seated.

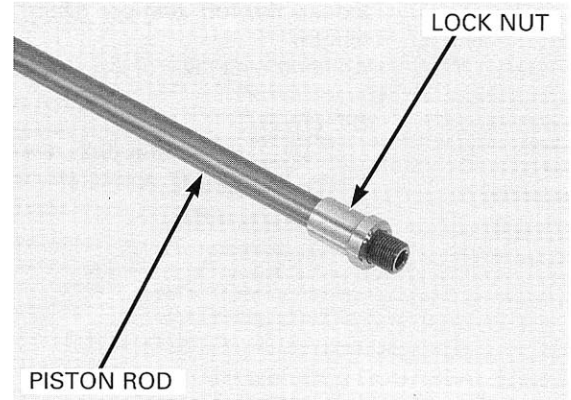

Turn the rebound adjuster and compression adjuster counterclockwise to the softest position.

Check the fork damper piston rod sliding surface for damage.  
Apply fork oil to the fork damper piston rod sliding surface.

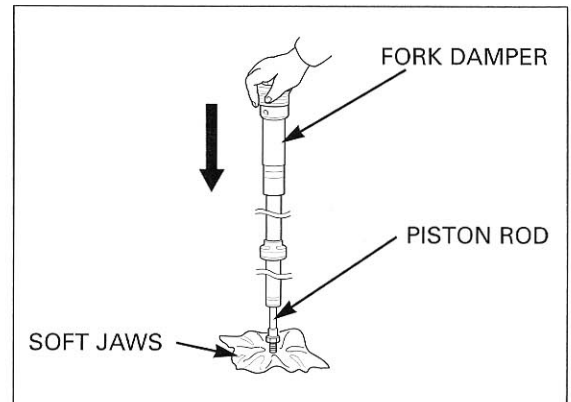

*Be careful not to bend or damage the fork damper piston rod when the piston rod is stroked.*

Cover the piston rod end to prevent damage.

Blow out any the extra oil in the fork damper spring chamber by fully stroking the fork damper piston rod.

*By doing this procedure, about 17 cm<sup>3</sup> of fork fluid will be drained from the damper spring chamber through the oil hole and cause 168 cm<sup>3</sup> (After '02: 178 cm<sup>3</sup>) of fork fluid to be left in the chamber.*

Drain the extra oil from the fork damper spring chamber oil hole.

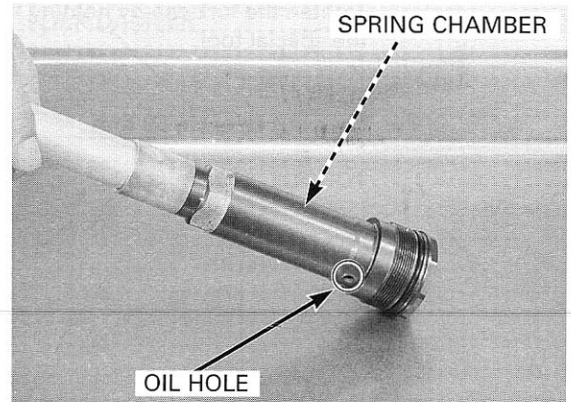

Blow out any oil from the fork damper spring chamber using compressed air.

Wipe off the oil completely from the fork damper.

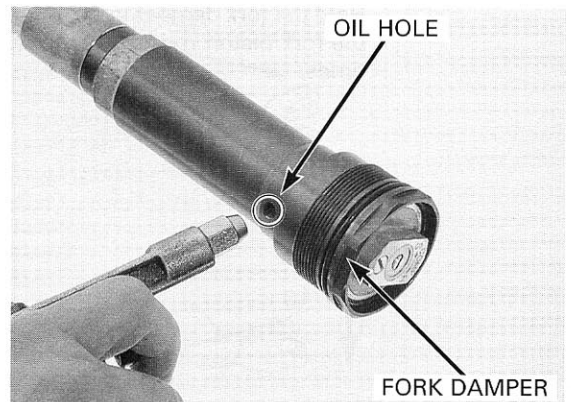



If you cannot use compressed air, remove the plug bolt on the fork cap.  
Hold the fork damper upside down for 10 minutes and drain the oil from the fork damper spring chamber.

Tighten the plug bolt to the specified torque.

**TORQUE: 1.2 N·m (0.12 kgf·m, 0.9 lbf·ft)**

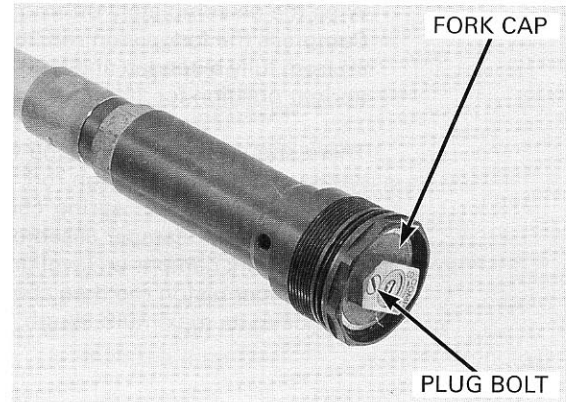

### FORK DAMPER OPERATION INSPECTION

Turn the compression adjuster counterclockwise to the softest position.

Check the fork damper piston rod sliding surface for damage.

Apply fork oil to the fork damper piston rod sliding surface.

Inspect the fork damper operation after air bleeding (page 11–18).

Cover the piston rod end to prevent damage.

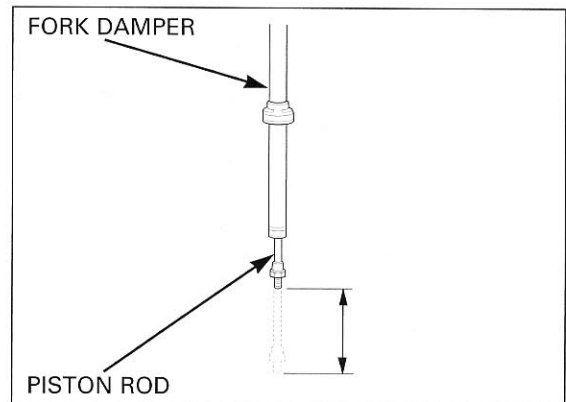

*Be careful not to bend or damage the fork damper piston rod when the piston rod is stroked.*

Fully stroke the fork damper piston rod by pushing down the fork damper.

Check the fork damper piston rod for smooth operation.

If the fork damper piston rod operation is not smooth, check the piston rod for bends or damage.

Hold the fork damper on level ground while the fork damper piston rod is fully extended and compressed by hand.

Release the fork damper piston rod then check that the piston rod extends to its maximum length.

If the fork damper piston rod does not extend to maximum, bleed the fork damper again.

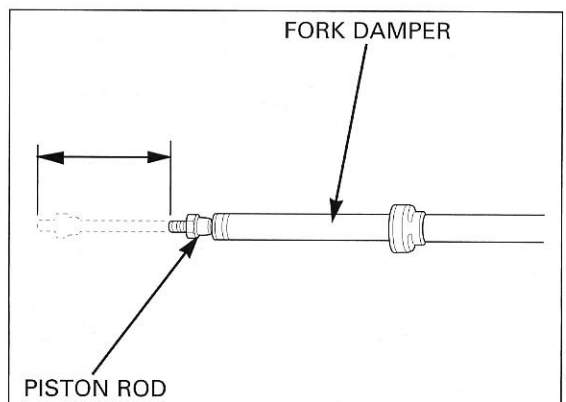

# FRONT WHEEL/SUSPENSION/STEERING

Wipe the oil completely off from the fork damper.  
Compress the fork piston rod 200 – 250 mm (7.9 – 9.8 in) from fully extended and hold the fork damper in an upright position for 10 minutes.

There should be no oil leaking from the fork damper spring chamber and piston rod.  
If oil leaks from the spring chamber or piston rod, replace the fork damper assembly.  
Hold the fork damper on level ground and release the fork damper piston rod then check that the piston rod extends to its maximum length.

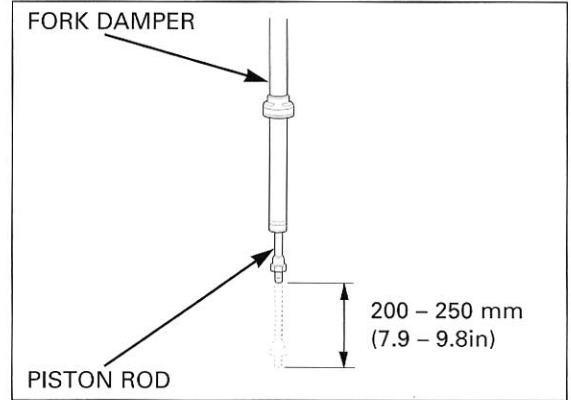

## FORK DAMPER INSTALLATION/PREPARATION

If the outer pipe and slider (fork) have not been disassembled, turn the fork upside down for 20 minutes and drain the oil from the inside of the outer pipe and slider completely.

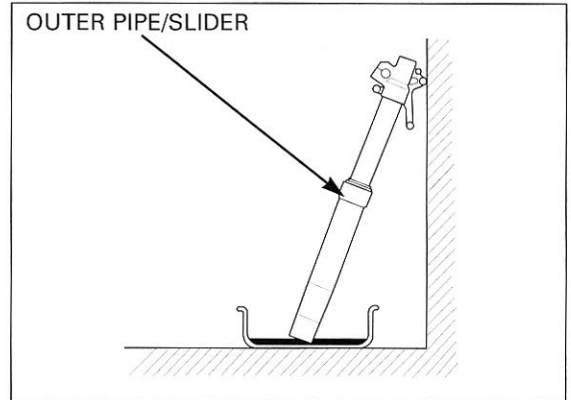

Amount of fork oil left in the fork (within damper and spring) unit: cm<sup>3</sup>

°C/°F \ minute	5	10	20	35	55	85	145
30/86	7.1	5.9	4.7	4.2	3.5	3.5	3.5
20/68	10.6	8.2	7.1	5.9	5.6	4.7	4.7
10/50	11.8	8.3	7.2	6.2	5.8	4.9	4.8
0/32	12.9	10.6	9.4	8.2	7.9	7.1	5.9

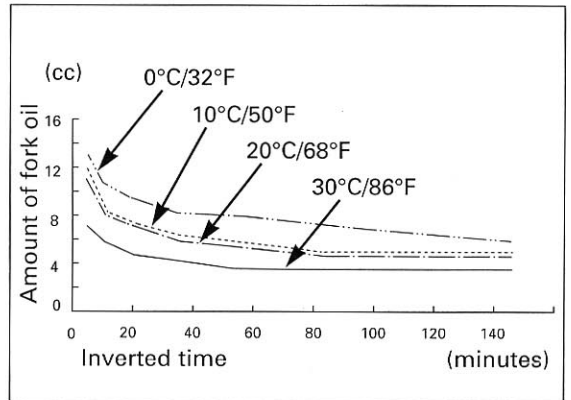

If the fork damper has not been disassembled from the outer pipe/slider, turn it upside down for 20 minutes and drain the oil from the inside of the outer pipe and slider completely (12 cm<sup>3</sup> at 20 °C/68 °F).

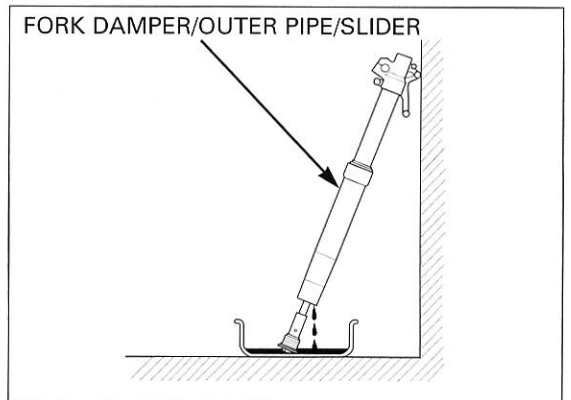

Amount of fork oil left in the fork  
(within damper and spring) unit: cm<sup>3</sup>

minute °C/°F	5	10	20	35	55	85	145
30/86	27	15.3	10.6	9.4	8.3	7.9	7.9
20/68	29.4	16.5	11.8	10.6	9.4	8.2	8.2
10/50	28.2	21.2	16.5	15.3	12.9	11.8	11.8
0/32	30.6	22.4	18.8	16.5	16.5	15.3	14.1

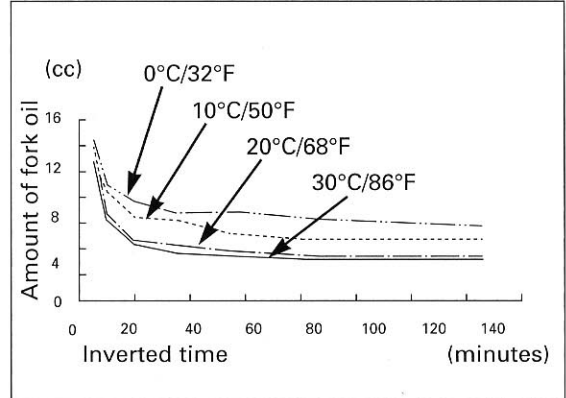

Tighten the lock nut fully and measure the length as shown.

**STANDARD:**

- '02: 15 – 16 mm (0.59 – 0.62 in)
- After '02: 11 – 13 mm (0.43 – 0.51 in)

Wipe the oil completely off from the fork damper.

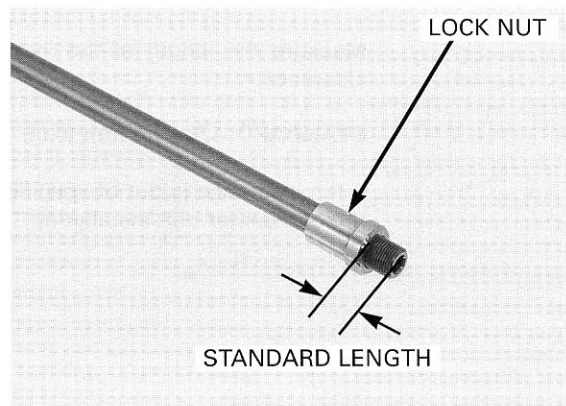

**FORK DAMPER INSTALLATION**

Wipe the oil off completely from the fork spring.  
Install the fork spring.  
Temporarily install the fork damper to the fork.

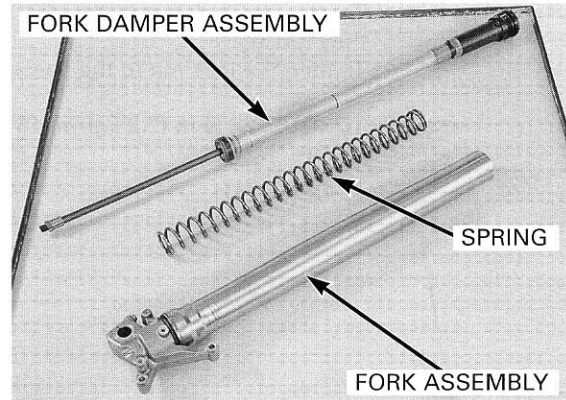

*Do not overtighten the vise on the axle holder.*

Set the lower end (axle holder) of the slider in a vise with a piece of wood or soft jaws to avoid damage.

Push out the fork damper piston rod from the axle holder of the slider by pushing the fork damper. While the fork damper is pushed, install the special tool or mechanic's stopper tool between the axle holder and lock nut.

**TOOL:**

Piston base

07958-2500001

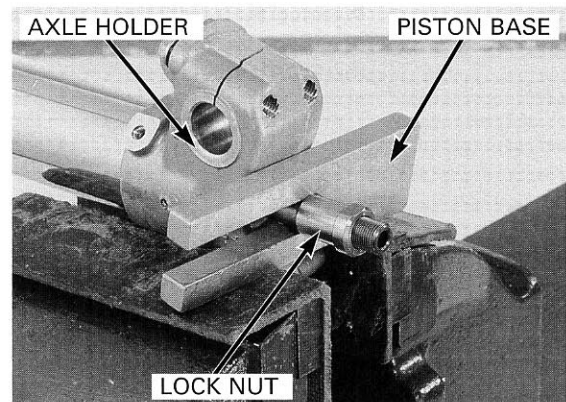

## FRONT WHEEL/SUSPENSION/STEERING

Measure the combined length of the lock nut and piston rod end again.

**STANDARD:**

'02: 15 – 16 mm (0.59 – 0.62 in)

After '02: 11 – 13 mm (0.43 – 0.51 in)

*Check the push rod installation by turning the push rod right and left.*

Install the adjuster rod into the piston rod until it stops.

Install the fork center bolt to the fork damper piston rod by aligning the flat-side of the center bolt adjusting rod with the flat-side of the push rod.

Tighten the center bolt fully by hand.

Measure the length of the lock nut and center bolt clearance.

**STANDARD: 1.5 – 2.0 mm (0.06 – 0.08 in)**

If the clearance is out of specification, check the lock nut and center bolt installation.

Tighten the lock nut to the center bolt by hand; until they touch.

Tighten the lock nut to the specified torque.

**TORQUE: 22 N·m (2.2 kgf·m, 16 lbf·ft)**

Remove the special tool or mechanic's stopper tool between the axle holder and lock nut while pushing the fork damper.

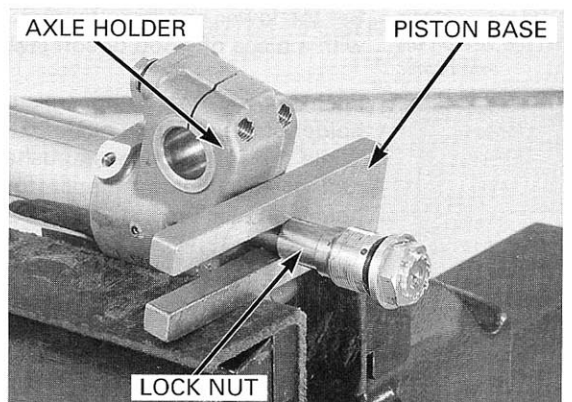
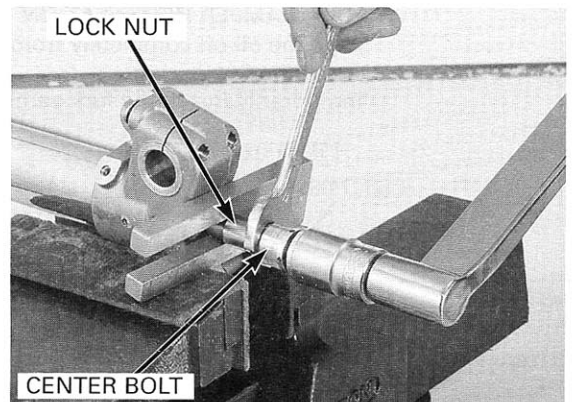
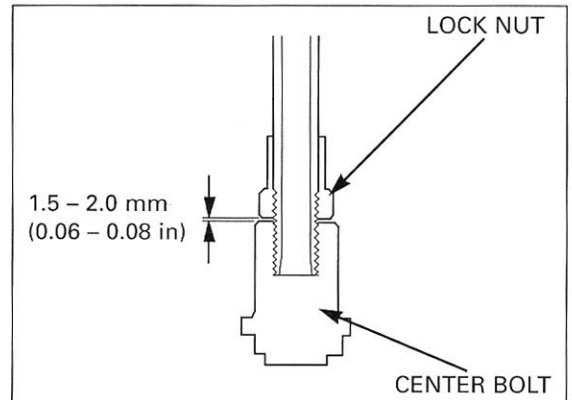
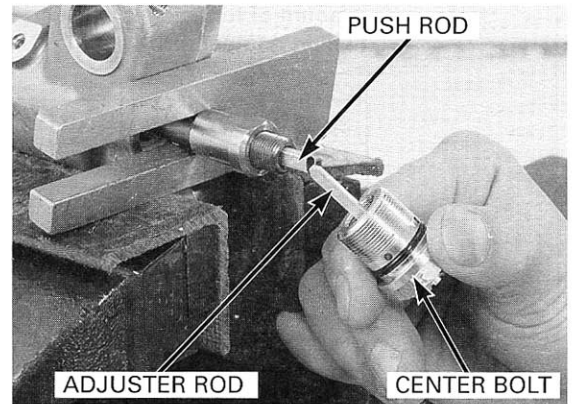

Install the center bolt to the axle holder and tighten it to the specified torque.

**TORQUE: 69 N·m (7.0 kgf·m, 51 lbf·ft)**

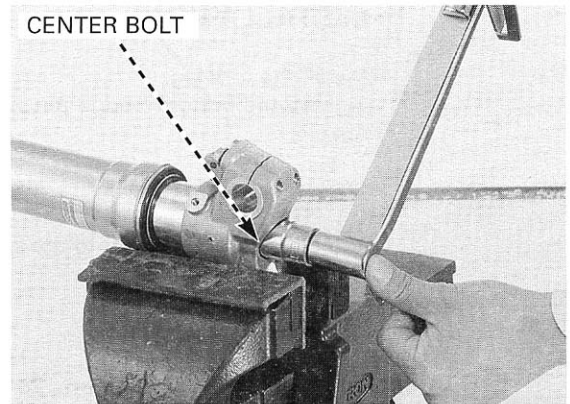

Measure the length between the axle holder and outer pipe.

**STANDARD: 317 ± 2 mm**

Compare the length at assembly and disassembly; they should be the same length.

If the length at assembly is longer than at disassembly, check the center bolt and lock nut installation.

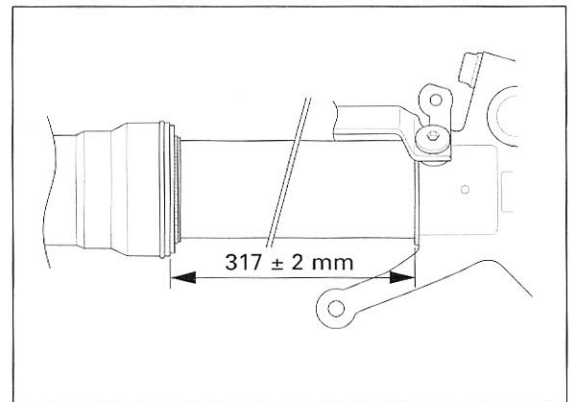

### OIL CAPACITY ADJUSTMENT

Remove the fork cap from the outer pipe.  
Pour the recommended fork oil into the fork leg.

**RECOMMENDED OIL: Pro Honda HP Fork Oil 5W or equivalent**

**STANDARD CAPACITY:**

'02: 419 cm<sup>3</sup> (14.2 US oz)

After '02: 405 cm<sup>3</sup> (13.7 US oz)

Be sure the oil capacity is the same in both fork legs.

'02:

Maximum oil capacity	441 cm <sup>3</sup> (14.9 US oz)	Slightly stiffer as it nears full compression.
Minimum oil capacity	345 cm <sup>3</sup> (11.7 US oz)	Slightly softer as it nears full compression.

After '02:

Maximum oil capacity	423 cm <sup>3</sup> (14.3 US oz)	Slightly stiffer as it nears full compression.
Minimum oil capacity	327 cm <sup>3</sup> (11.1 US oz)	Slightly softer as it nears full compression.

Pull up the outer pipe slowly and install the fork damper to the outer pipe.

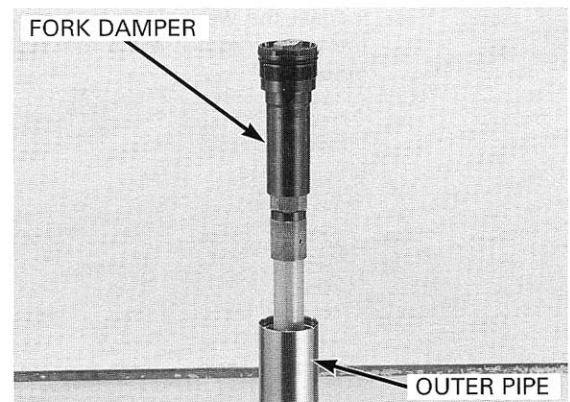
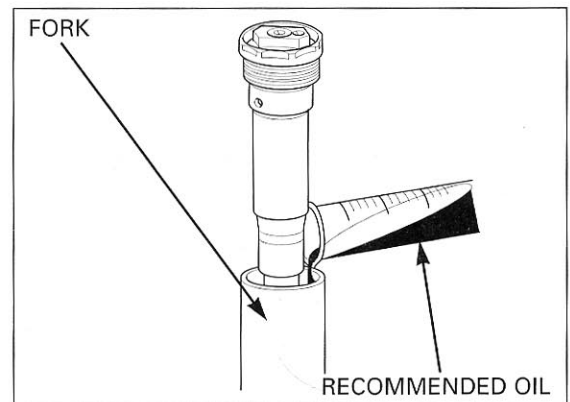

## FRONT WHEEL/SUSPENSION/STEERING

### INSTALLATION

Install the fork leg.  
Tighten the bottom bridge pinch bolt to the specified torque.

**TORQUE: 20 N·m (2.0 kgf·m, 14 lbf·ft)**

Tighten the fork damper to the specified torque.

#### TOOL:

Lock nut wrench, 50 mm      07WMA-KZ30100

**TORQUE: 34 N·m (3.5 kgf·m, 25 lbf·ft)**

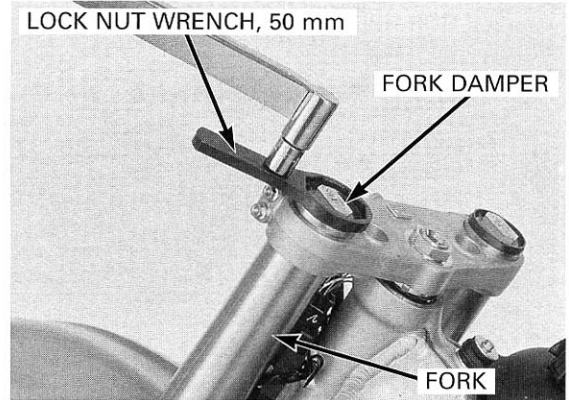

### STANDARD POSITION

Loosen the bottom pinch bolts.  
For ease when releasing the air pressure after the forks are installed, position the fork outer pipes so that the pressure release screws are in front of the rebound adjusters.  
Align the top surface of the top bridge with the index line of the outer pipe.

For alternate position, see the Owner's Manual.

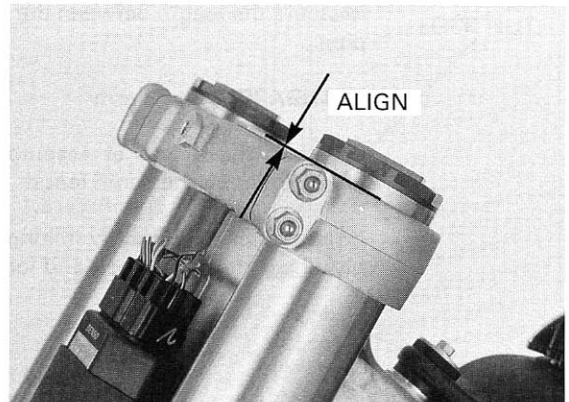

Tighten the bottom bridge pinch bolts to the specified torque.

**TORQUE: 20 N·m (2.0 kgf·m, 14 lbf·ft)**

Tighten the top bridge pinch bolts to the specified torque.

**TORQUE: 22 N·m (2.2 kgf·m, 16 lbf·ft)**

#### NOTICE

*Overtightening the pinch bolts can deform the outer pipes. A deformed outer pipe must be replaced.*

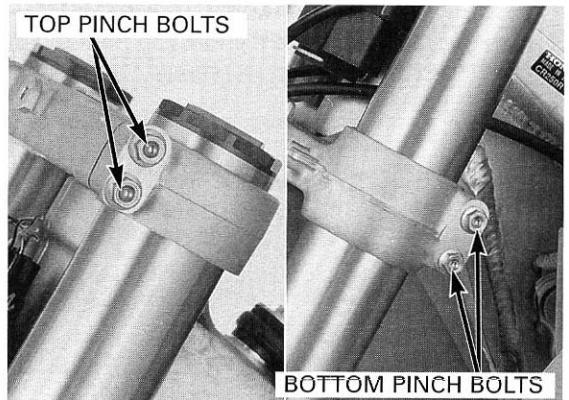

Inspect the wear rings for wear or damage. Replace the wear ring if it is 1.5 mm (0.06 in) or flat with the outer pipe.

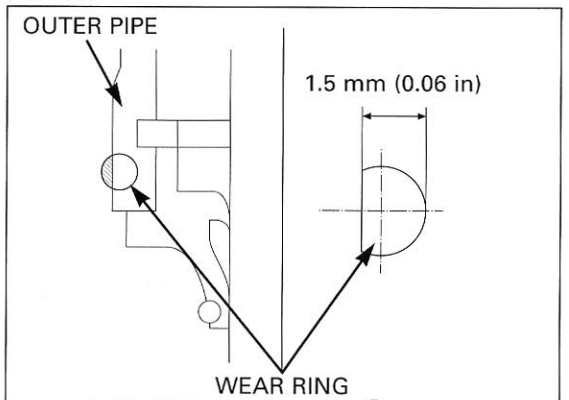

Install each wear ring with the end gap facing rearward.

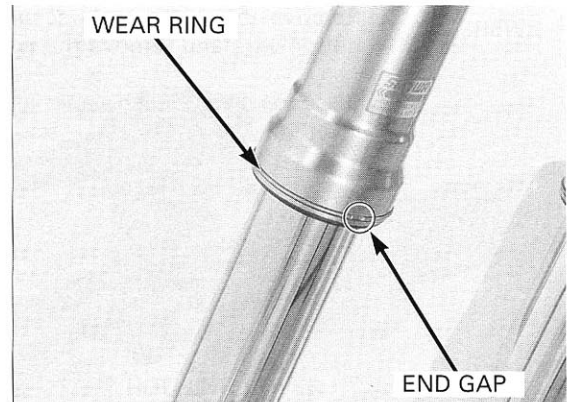

Clean and apply a locking agent to the fork protector mounting bolt threads. Install the fork protector and tighten the mounting bolts to the specified torque.

**TORQUE: 7 N·m (0.7 kgf·m, 5.1 lbf·ft)**

Clean and apply a locking agent to the front brake caliper mounting bolt threads. Install the front brake caliper and tighten the mounting bolts to the specified torque.

**TORQUE: 30 N·m (3.1 kgf·m, 22 lbf·ft)**

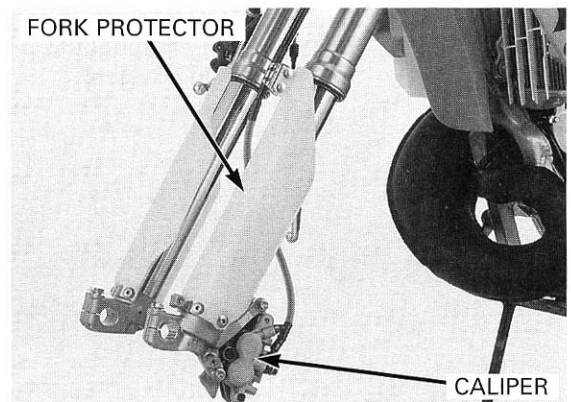

Return rebound adjuster and compression adjuster to the original positions as noted during removal.

Install the front wheel (page 11-8).

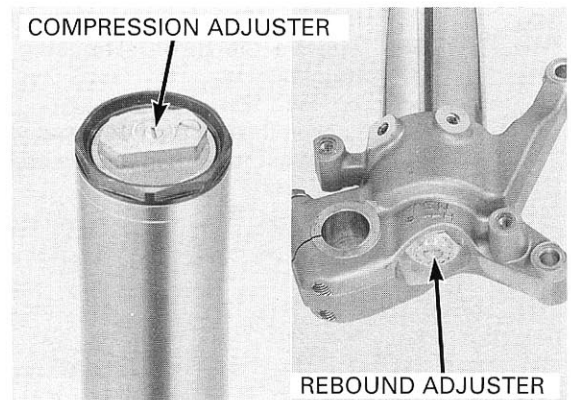

## HANDLEBAR

### REMOVAL

Disconnect the engine stop button connectors.

Unhook the holding tab of the number plate (page 2-3).

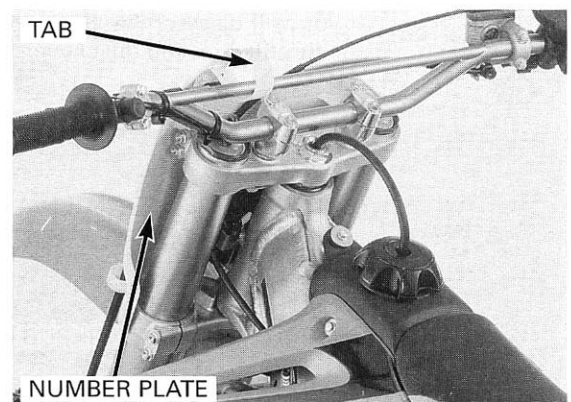

## FRONT WHEEL/SUSPENSION/STEERING

Remove the wire bands securing the engine stop button wire and remove the engine stop button.

Disconnect the clutch cable and remove the clutch lever bracket.

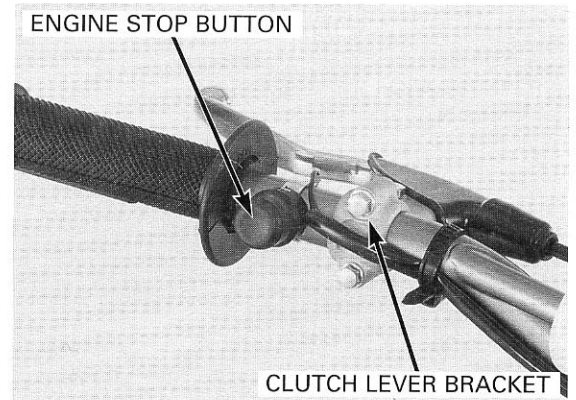

*Do not disconnect the hydraulic line.*

Remove the front brake master cylinder, with its holder, keeping it upright to prevent air from entering the hydraulic system.

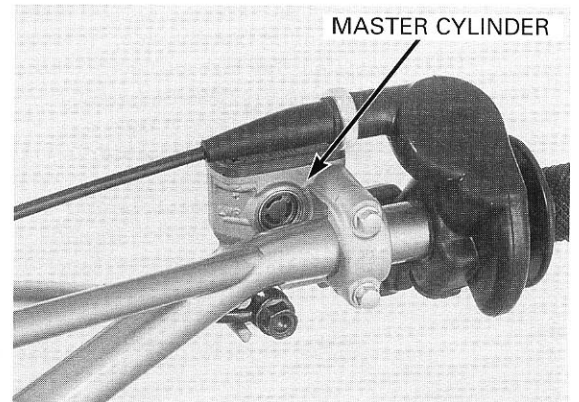

If you will not disassemble the throttle housing, remove the throttle housing as an assembly as follows.

Loosen the throttle housing bolts, turn the handlebar to the left fully, then remove the throttle housing.

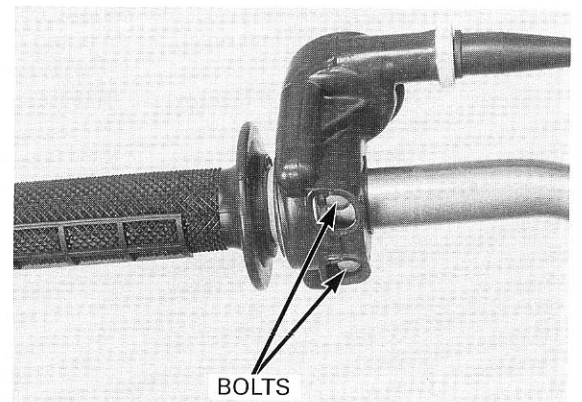

If you will disassemble the throttle housing, remove the throttle housing dust cover.

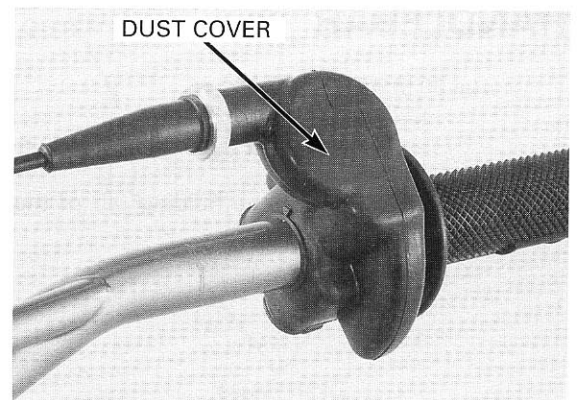



## FRONT WHEEL/SUSPENSION/STEERING

Remove the throttle housing cover by removing the screw. Slide the rubber protector off and loosen the lock nut and adjuster.

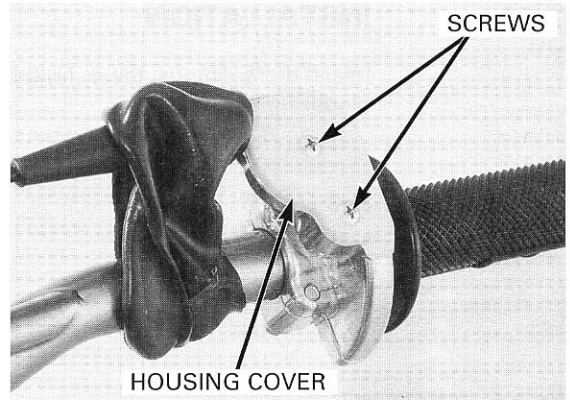

Remove the throttle cable and collar.

Disconnect the throttle cable end from the throttle drum by removing the lock nut and adjuster.

Loosen the throttle housing mounting bolts and remove the throttle drum from the handlebar.

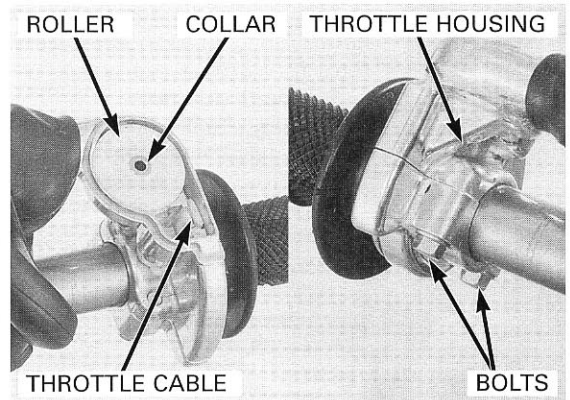

Loosen the handlebar upper holder nuts.

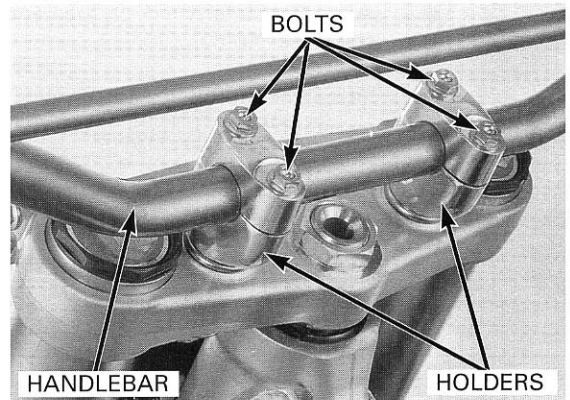

Remove the bolts, handlebar upper holders and handlebar.

Remove the handlebar lower holder nuts, washers, lower holders and bushings.

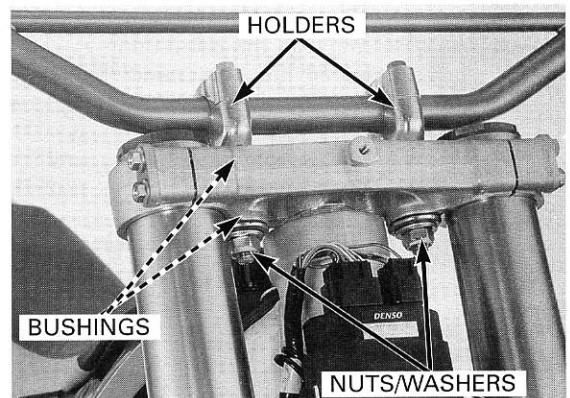

**INSTALLATION**

Install the bushings, lower holders, washers and handlebar holder nuts.

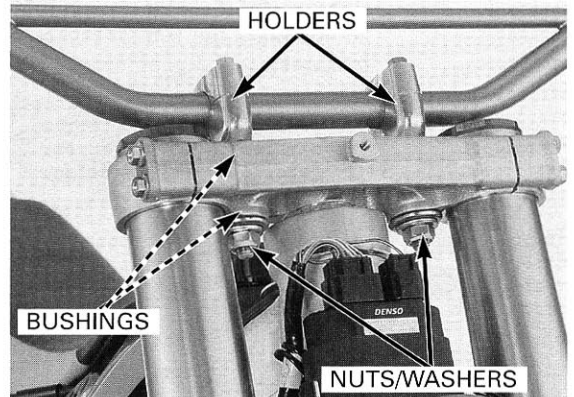

Using optional handlebar lower holders, the handlebar position may be moved 3 mm (0.12 mm) forward or rearward.

- Standard: no offset
- Optional: 3 mm (0.12 in) offset to rearward
- Optional 180 degrees turn: 3 mm (0.12 in) offset to forward

Temporarily install the handlebar and upper holders. Tighten the lower holder nuts to the specified torque.

**TORQUE: 44 N·m (4.5 kgf·m, 33 lbf·ft)**

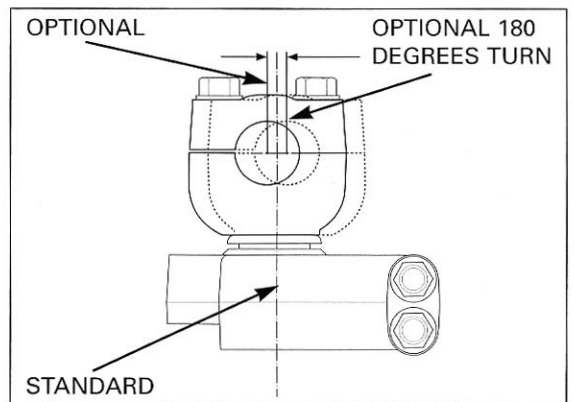

Align the punch mark on the handlebar with the top of the lower holder.

Place the upper holder on the handlebar with the punch marks facing forward.

Install and tighten the front handlebar holder bolts first, then tighten the rear bolts.

**TORQUE: 22 N·m (2.2 kgf·m, 16 lbf·ft)**

Apply Honda Bond A or Honda Hand Grip Cement (U.S.A. only) to the inside surface of the grips and to the clean surface of the left handlebar.

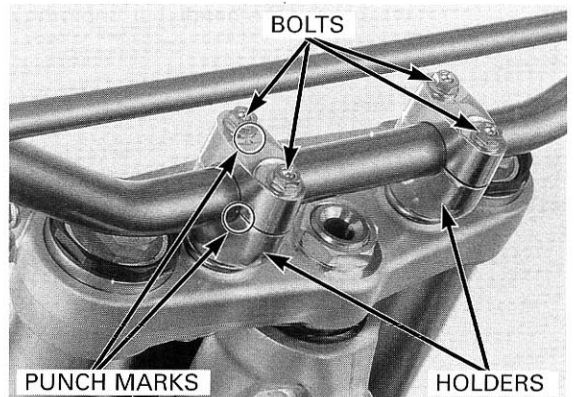

Install the left handlebar grip to the handlebar aligning the mark on the left grip with the punch mark on the handlebar.

Install the right handlebar grip to the throttle pipe aligning the mark on the right grip with the edge of the throttle pipe end.

Wait 3 – 5 minutes and install the grips. Rotate the grips for even application of the adhesive.

*Allow the adhesive to dry for approximately 1 hour before using.*

Align the mark on the left grip with the punch mark on the handlebar.

Align the mark on the right grip with the edge of the throttle pipe end.

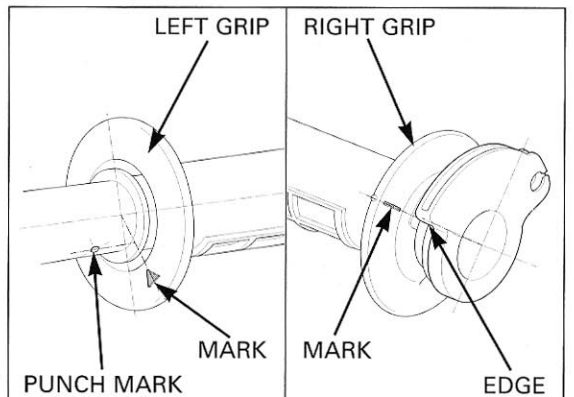

If you did not disassemble the throttle housing, place the dust cover over the throttle housing. Align the "Δ" mark on the dust cover with the punch mark on the handlebar. Tighten the throttle housing upper bolt first, then the lower bolt.

**TORQUE: 9 N·m (0.9 kgf·m, 6.5 lbf·ft)**

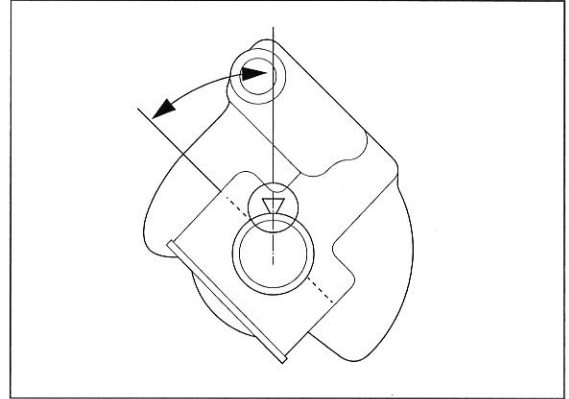

If you disassembled the throttle housing, install it as follows:  
Apply a thin coat of oil to the sliding surface of the right handlebar grip and throttle housing.

Connect the throttle cable end to the throttle drum.

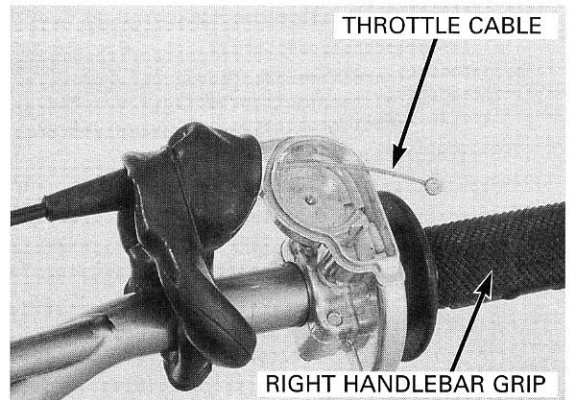

Install the throttle housing aligning the punch mark on the housing with the punch mark on the handlebar. Tighten the upper bolt first, then the lower bolt.

**TORQUE: 9 N·m (0.9 kgf·m, 6.5 lbf·ft)**

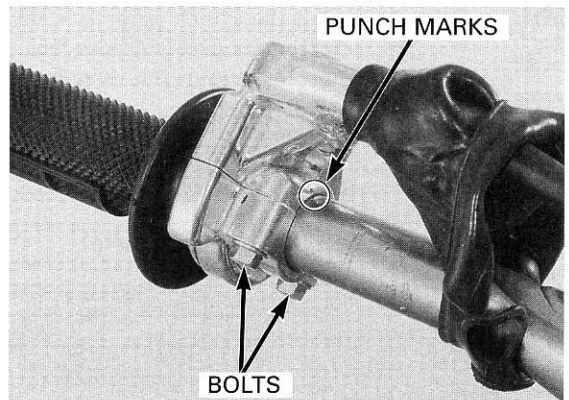

Install the throttle cable roller and collar.  
Install the throttle housing cover and tighten the screws to the specified torque.

**TORQUE: 1.5 N·m (0.15 kgf·m, 1.1 lbf·ft)**

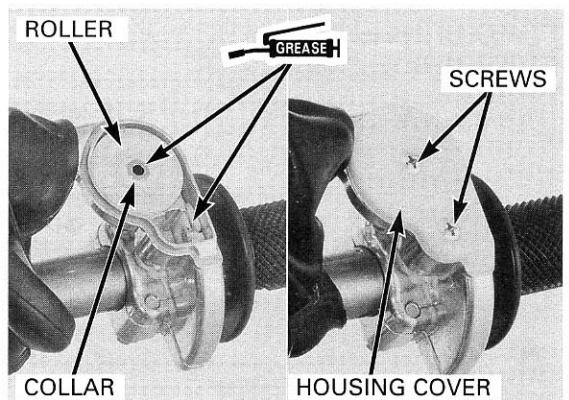

## FRONT WHEEL/SUSPENSION/STEERING

Place the dust cover over the throttle housing.  
Align the "Δ" mark on the dust cover with the punch mark on the handlebar.  
Tighten the throttle housing upper bolt first, then the lower bolt.

**TORQUE: 9 N·m (0.9 kgf·m, 6.5 lbf·ft)**

Adjust the throttle grip free play (page 3–5).

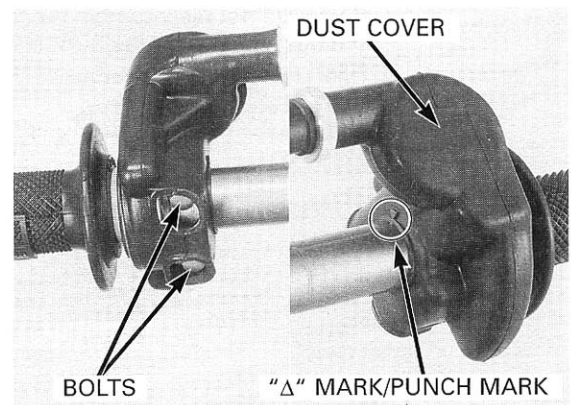

Position the brake master cylinder on the handlebar.

Install the master cylinder holder with the "UP" mark facing up and align the end of the holder with the punch mark on the handlebar.

Tighten the upper master cylinder holder bolt first, then tighten the lower bolt.

**TORQUE: 9.9 N·m (1.0 kgf·m, 7 lbf·ft)**

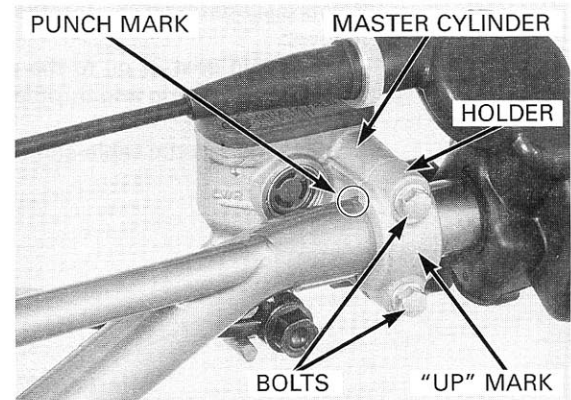

Install the clutch lever bracket and holder with the punch mark on the holder facing up.  
Align the end of the holder with the punch mark on the handlebar.  
Tighten the upper bolt first, then the lower bolt.

**TORQUE: 9 N·m (0.9 kgf·m, 6.5 lbf·ft)**

Connect the clutch cable.

Adjust the clutch lever free play (page 3–15).

Route the engine stop button wire properly.  
Install the engine stop button on the handlebar and align the end of the engine stop button holder with the punch mark on the handlebar.  
Install and tighten the engine stop button screw with the ground wire.

**TORQUE: 1.5 N·m (0.15 kgf·m, 1.1 lbf·ft)**

Attach the engine stop button wire to the handlebar using the wire bands.

Route the fuel tank breather hose as shown.  
Route the number plate tab around the handlebar cross bar as shown.

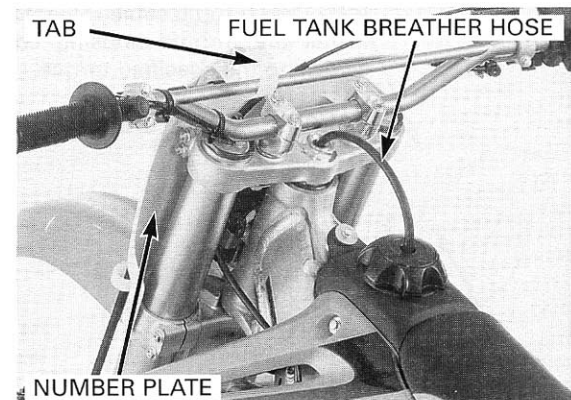
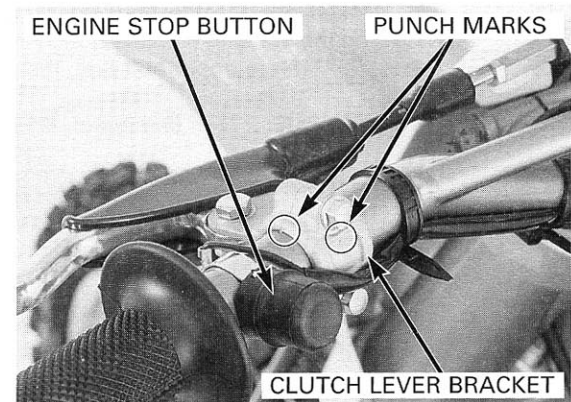

## STEERING STEM

### REMOVAL

Remove the handlebar (page 11-27).  
 Remove the front wheel (page 11-4).  
 Remove the number plate (page 2-3).

Remove the fender bolts, collars and washers.  
 Remove the front fender.  
 Remove the bolt and brake hose guide.

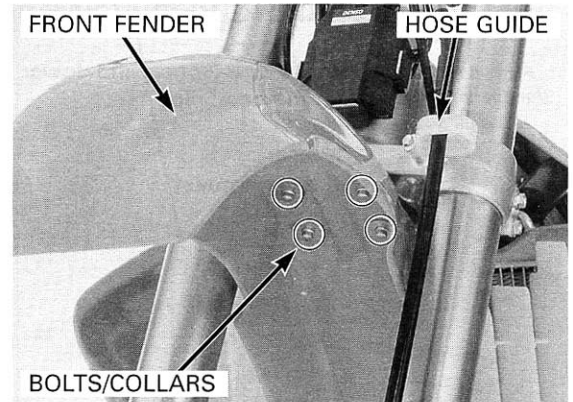

Remove the steering stem nut and washer.

Remove the fork legs (page 11-9).

Remove the fork top bridge.

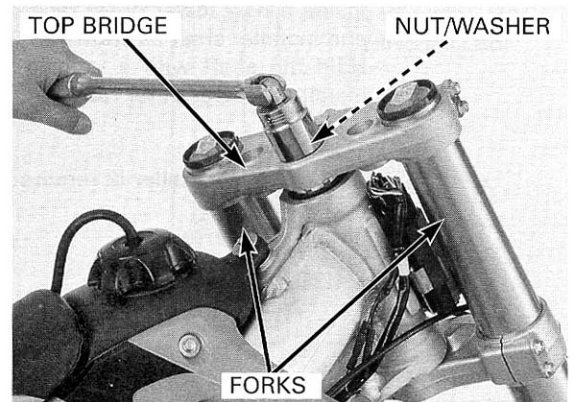

Remove the steering stem adjusting nut.

#### TOOL:

<b>Steering stem socket</b>	07916-3710100 or 07916-3710101
<b>Adjustable pin spanner wrench</b>	07702-0020001 (U.S.A. only)
<b>Extension bar</b>	07716-0020500 or equivalent commercially available in U.S.A.

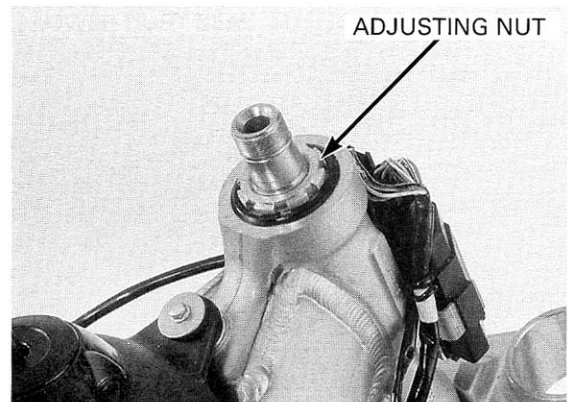

Remove the steering stem.  
 Remove the dust seal and upper tapered roller bearing.

Check the head bearings and outer races for wear or damage.

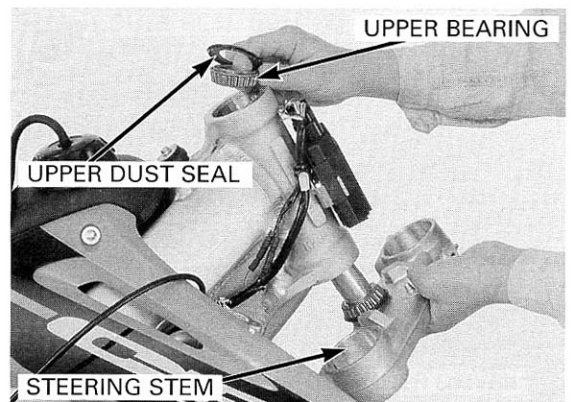

## FRONT WHEEL/SUSPENSION/STEERING

### BEARING REPLACEMENT

*Always replace the bearings and races as a set.*

Remove the upper and lower bearing outer races from the head pipe.

**TOOL:**

**Ball race remover** 07946-3710500

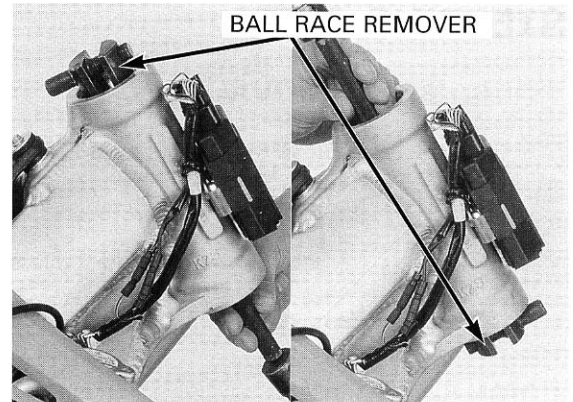

Install a new lower outer race, bearing race installer and installer shaft as shown. Hold the shaft with a wrench, turn the installer to install the lower outer race.

**TOOLS:**

**Bearing race installer (2 required)**

07VMF-KZ30100

**Installer shaft**

07VMF-KZ30200

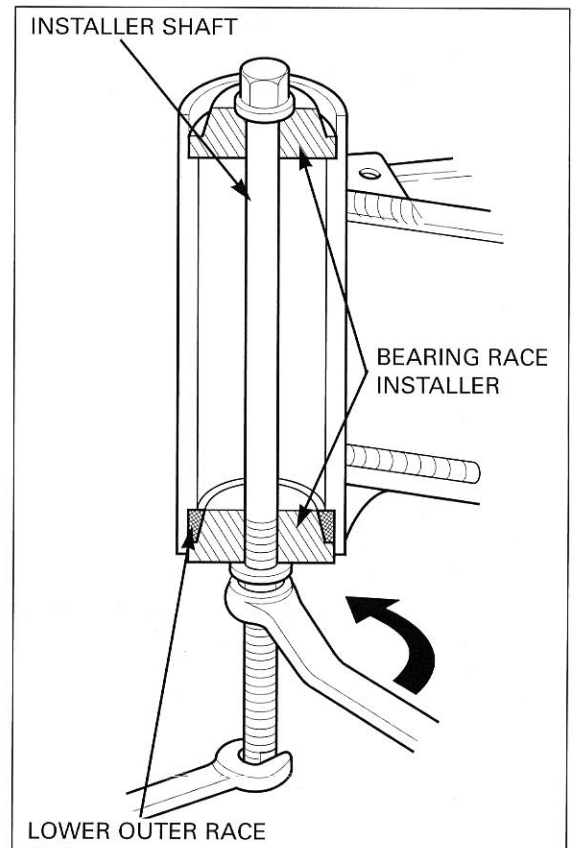

Install a new upper outer race, bearing race installer and installer shaft as shown. Hold the shaft with a wrench, turn the installer to install the upper outer race.

**TOOLS:**

Bearing race installer (2 required)

07VMF-KZ30100

Installer shaft

07VMF-KZ30200

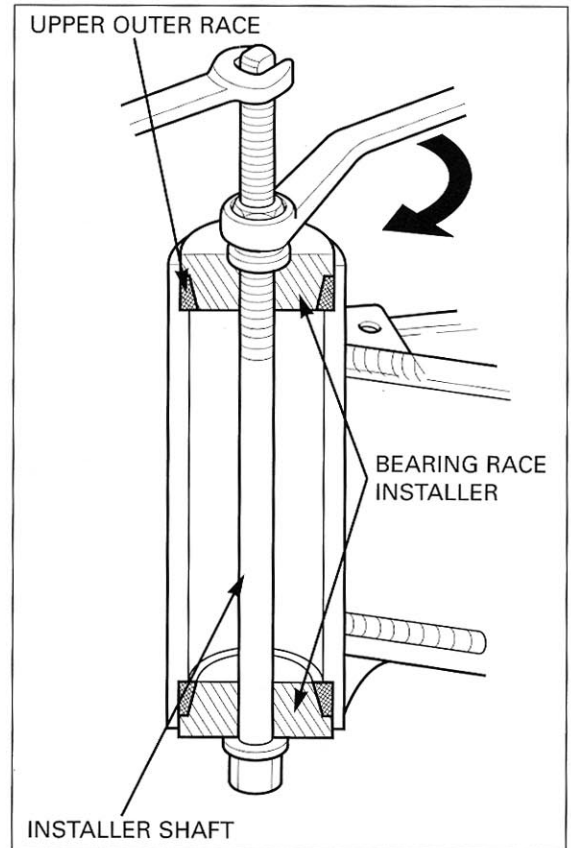

Temporarily install the stem nut to avoid damaging the steering stem threads.

Remove the lower tapered roller bearing and dust seal from the steering stem.

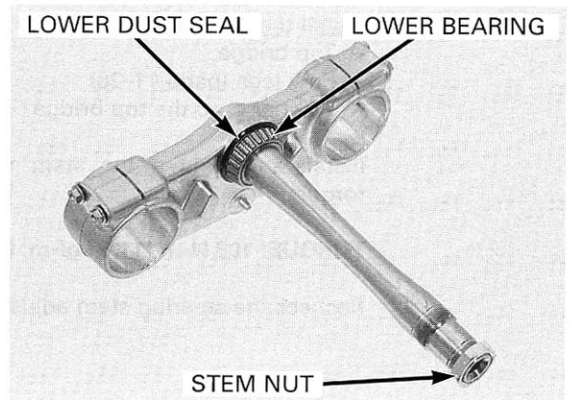

Install the new dust seal.

Pack the upper and lower tapered roller bearings with grease.

Install the lower bearing using a hydraulic press and special tool as shown.

**TOOL:**

Attachment, 30 mm I.D.

07746-0030300

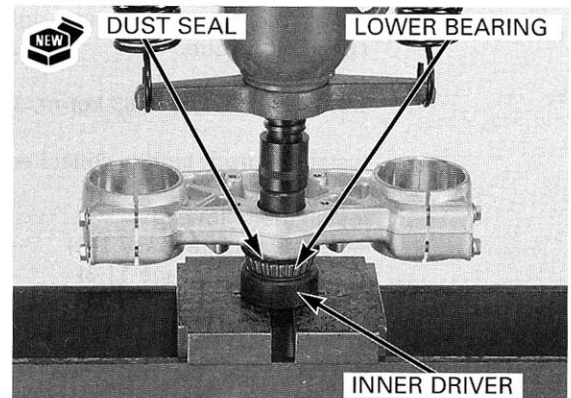

## FRONT WHEEL/SUSPENSION/STEERING

### INSTALLATION

Apply grease to all of the bearing surfaces.

Install the upper tapered roller bearing in the steering head.

Slide the steering stem into the steering head from the bottom.

Install the dust seal.

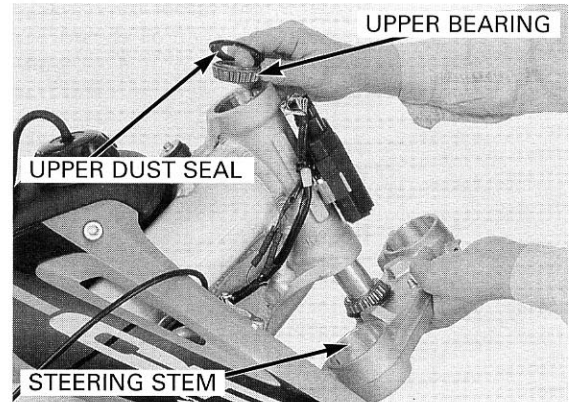

Install the steering head adjusting nut.

Tighten the steering head adjusting nut with the steering stem socket.

**TORQUE: 7 N·m (0.7 kgf·m, 5.1 lbf·ft)**

**TOOL:**

**Steering stem socket** 07916-3710100 or 07916-3710101  
**Adjustable pin spanner wrench** 07702-0020001 (U.S.A. only)

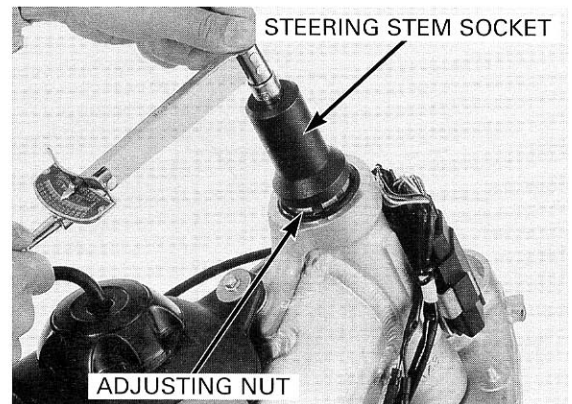

Turn the steering stem lock-to-lock five times to seat the bearings, then tighten the adjusting nut again.

Install the following:

- Top bridge
- Fork legs (page 11-26)
- Washer onto the top bridge

Install and tighten the stem nut to the specified torque.

**TORQUE: 108 N·m (11.0 kgf·m, 80 lbf·ft)**

Recheck the steering stem adjustment.

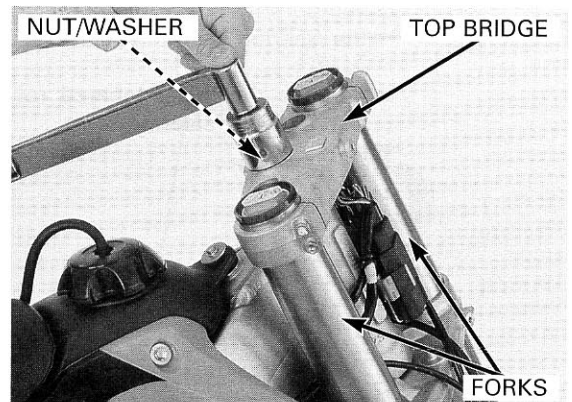

Install the brake hose and tighten the bolt to the specified torque.

**TORQUE: 5.2 N·m (0.53 kgf·m, 3.8 lbf·ft)**

Install the front fender, collars and tighten the bolts.

Install the following:

- Number plate (page 2-3)
- Front wheel (page 11-8)
- Handlebar (page 11-30)

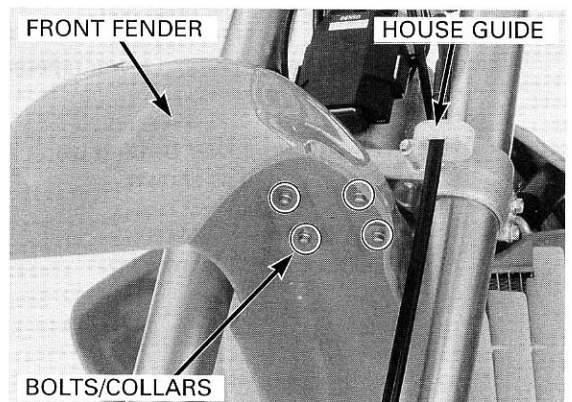



# REAR WHEEL/SUSPENSION

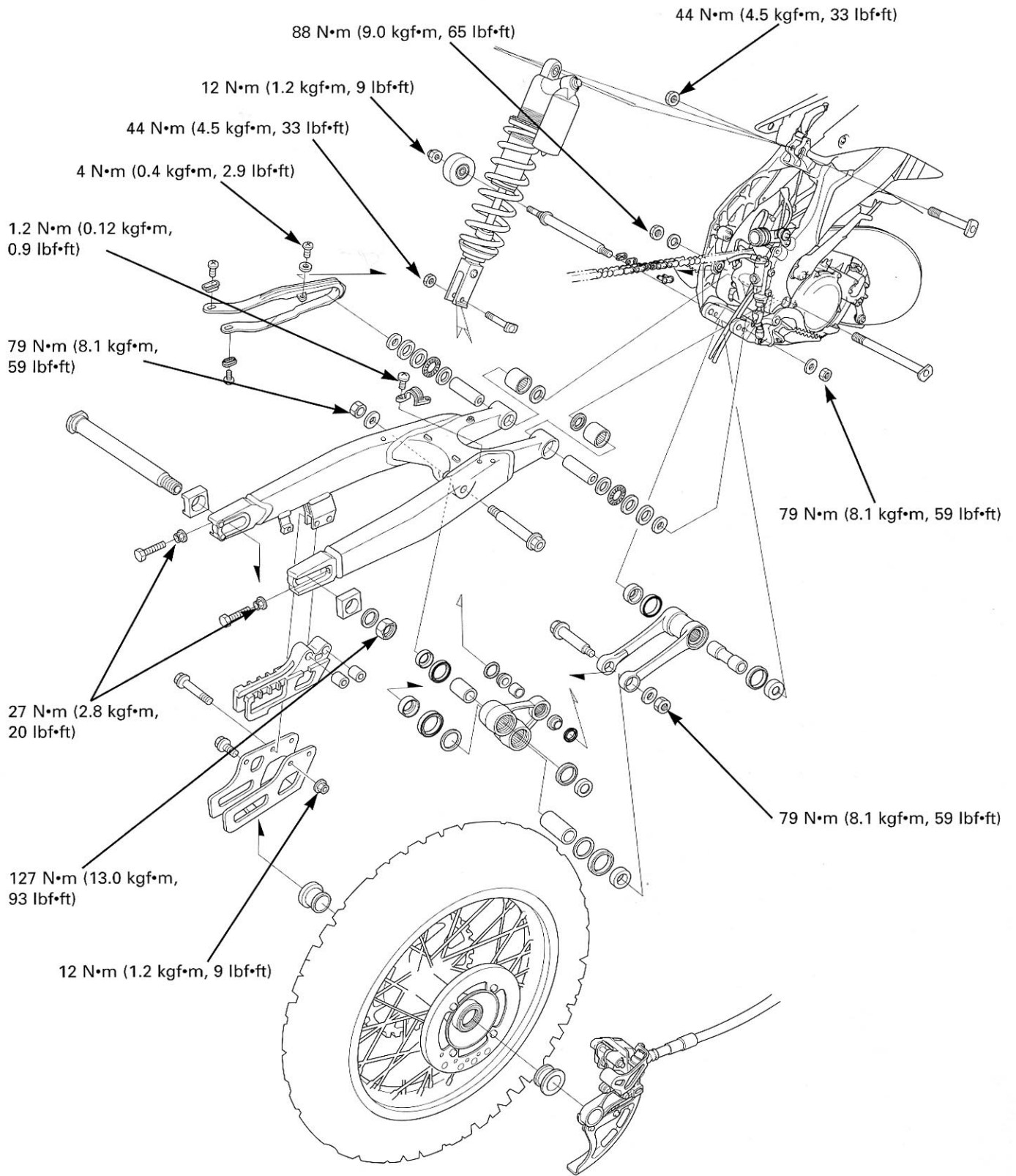

# 12. REAR WHEEL/SUSPENSION

<b>SERVICE INFORMATION</b>	<b>12-1</b>	<b>SHOCK ABSORBER</b>	<b>12-10</b>
<b>TROUBLESHOOTING</b>	<b>12-3</b>	<b>SHOCK LINKAGE</b>	<b>12-25</b>
<b>REAR WHEEL</b>	<b>12-4</b>	<b>SWINGARM</b>	<b>12-30</b>

## SERVICE INFORMATION

### GENERAL

#### **⚠ CAUTION**

- Use only nitrogen to pressurize the shock absorber. The use of an unstable gas can cause a fire or explosion resulting in serious injury.
- The shock absorber contains nitrogen under high pressure. Do not allow fire or heat near the shock absorber.
- Before disposal of the shock absorber, release the nitrogen by pressing the valve core. Then remove the valve from the shock absorber.

- Brake dust may contain asbestos fibers.
- Never use an air hose or dry brush to clean brake assemblies.
- Keep grease off of the brake pads and disc.
- A contaminated brake disc or pad reduces stopping power. Discard contaminated pads and clean a contaminated disc with a high quality brake degreasing agent.
- When servicing the rear wheel, support the motorcycle using a safety stand or hoist.
- For optimum suspension performance and linkage component service life, the swingarm and shock linkage pivot bearings (along with related seals and bushings) should be disassembled, cleaned, inspected for wear and lubricated with multi-purpose grease NLGI No.2 (molybdenum disulfide additive) every three races or 7.5 hours of operation.
- Optional rear wheel sprockets, drive chain, shock springs and spring preload pin spanners are available. Refer to General Information, section 1.
- Refer to section 13 for brake system information.
- Use genuine Honda replacement bolts and nuts for all suspension pivot and mounting points.

**12**

### SPECIFICATIONS

Unit: mm (in)

ITEM		STANDARD	SERVICE LIMIT
Cold tire pressure		100 kPa (1.0 kgf/cm <sup>2</sup> , 15 psi)	—
Axle runout		—	0.20 (0.008)
Wheel rim runout	Radial	—	2.0 (0.08)
	Axial	—	2.0 (0.08)
Wheel hub-to-rim distance		47.00(1.850)	—
Drive chain slack		25 – 35 (1.0 – 1.4)	—
Drive chain size/link	DID	520DMA2-114	—
Drive chain slider thickness		—	5 (0.2)
Drive chain tensioner roller O.D.	Upper	—	25 (0.98)
	Lower	—	39 (1.54)

## REAR WHEEL/SUSPENSION

ITEM		STANDARD	SERVICE LIMIT
Shock absorber	Damper gas pressure	981 kPa (10.0 kgf/cm <sup>2</sup> , 142 psi)	—
	Damper compressed gas	Nitrogen gas	—
	Damper rod compressed force at 13 mm compressed	20.0 – 24.0 kgf (44.1 – 52.9 lbf)	—
	Spring installed length (standard)	265 (10.43)	—
High speed compression damping adjuster standard position	'02	1•3/4 – 2•1/4 turns out form full in	—
	After '02	1•11/12 – 2•5/12 turns out form full in	—
Low speed compression damping adjuster standard position	'02	7 clicks out from full in	—
	After '02	8 clicks out from full in	—
Rebound damping adjuster standard position	'02	8 – 11 clicks out from full in	—
	After '02	4 – 7 clicks out from full in	—

## TORQUE VALUES

Rear axle nut	127 N•m (13.0 kgf•m, 94 lbf•ft)
Rear spoke nipple	3.7 N•m (0.38 kgf•m, 2.7 lbf•ft)
Rear rim lock	12 N•m (1.2 kgf•m, 9 lbf•ft)
Final driven sprocket nut	32 N•m (3.3 kgf•m, 24 lbf•ft) U–nut
Rear brake disc nut	16 N•m (1.6 kgf•m, 12 lbf•ft)
Rear wheel bearing retainer	44 N•m (4.5 kgf•m, 33 lbf•ft)
Drive chain adjusting nut	27 N•m (2.8 kgf•m, 20 lbf•ft)
Drive chain slider screw	4 N•m (0.4 kgf•m, 2.9 lbf•ft)
Shock absorber mounting bolt (upper)	44 N•m (4.5 kgf•m, 33 lbf•ft) U–nut
(lower)	44 N•m (4.5 kgf•m, 33 lbf•ft) U–nut
Shock absorber damper rod end nut	37 N•m (3.8 kgf•m, 27 lbf•ft) Stake.
Shock absorber damping adjuster	29 N•m (3.0 kgf•m, 22 lbf•ft) Stake.
Shock absorber spring lock nut	44 N•m (4.5 kgf•m, 33 lbf•ft)
Shock arm nut (swingarm side)	79 N•m (8.1 kgf•m, 59 lbf•ft) Apply oil to the threads and seating surface.
(shock link side)	U–nut
Shock link	79 N•m (8.1 kgf•m, 59 lbf•ft) U–nut
Swingarm pivot nut	88 N•m (9.0 kgf•m, 65 lbf•ft)
Rear brake hose guide screw	1.2 N•m (0.12 kgf•m, 0.9 lbf•ft)
Drive chain guide mounting nut	12 N•m (1.2 kgf•m, 9 lbf•ft) U–nut
Right and left step bolt (upper)	55 N•m (5.6 kgf•m, 41 lbf•ft)
(lower)	30 N•m (3.0 kgf•m, 23 lbf•ft)

**TOOLS**

Spoke nipple wrench, 6.6	070MA-KZ30100 or equivalent commercially available in U.S.A.
Bearing retainer wrench body	07710-0010401
Attachment, 42 x 47 mm	07746-0010300
Attachment, 24 x 26 mm	07746-0010700
Pilot, 20 mm	07746-0040500
Pilot, 25 mm	07746-0040600
Pilot, 19 mm	07746-0041400
Bearing remover shaft	07746-0050100
Bearing remover head, 25 mm	07746-0050800
Driver	07749-0010000
Attachment, 28 x 30 mm	07946-1870100
Driver	07949-3710001
Slider guide attachment	070MO-KZ30100 not available in U.S.A.
Slider guide, 16 mm	07PMB-KZ40100 not available in U.S.A.
Bearing retainer wrench, 48 x 15 mm	07YMA-KZ40100 or 07HMA-KS70100 (U.S.A. only)
Pin spanner	89201-KS6-810 2 required or
Pin spanner	07702-0020001 2 required.

**TROUBLESHOOTING****Soft suspension**

- Weak shock absorber spring
- Incorrect suspension adjustment
- Oil leakage from damper unit
- Tire pressure too low

**Hard suspension**

- Damaged shock absorber mounting bearing
- Bent damper rod
- Damaged swingarm pivot
- Bent swingarm pivot
- Incorrect suspension adjustment
- Tire pressure too high

**Steers to one side or does not track straight**

- Bent rear axle
- Axle alignment/chain adjustment not equal on both sides

**Rear wheel wobbles**

- Bent rim
- Worn rear wheel bearings
- Faulty tire
- Tire pressure too low
- Faulty swingarm pivot bearings

## REAR WHEEL/SUSPENSION

### REAR WHEEL

#### REMOVAL

Support the motorcycle securely using a hoist or equivalent.

Remove the axle nut and washer.

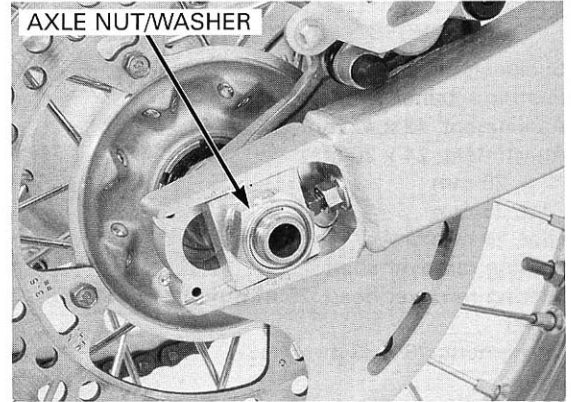

Push the rear wheel forward.  
Remove the drive chain from the driven sprocket.

Remove the axle from the left side and remove the rear wheel.

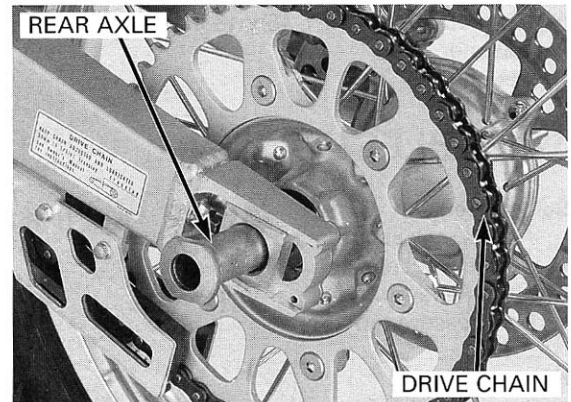

Remove the side collars.

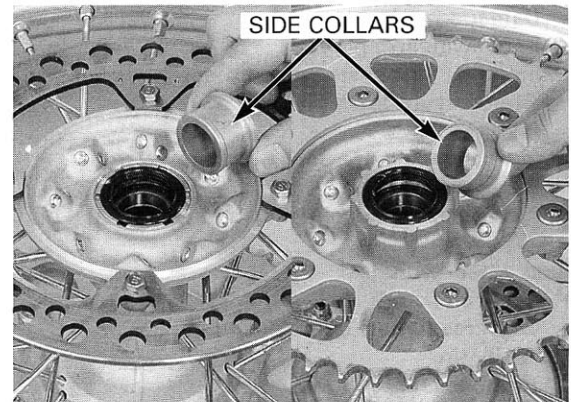

#### INSPECTION

##### AXLE

Place the axle in V-blocks and measure the runout.  
Actual runout is 1/2 the total indicator reading.

**SERVICE LIMIT: 0.20 mm (0.008 in)**

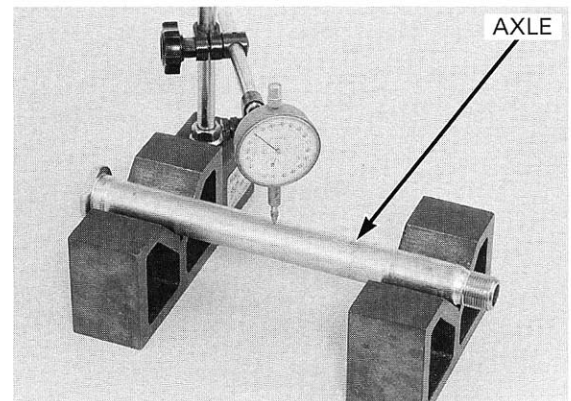

### WHEEL BEARING

Turn the inner race of each bearing with your finger. Bearings should turn smoothly and quietly. Also check that the bearing outer race fits tightly in the hub.

*Replace the wheel bearings in pairs.*

Remove and discard the bearings if the races do not turn smoothly and quietly, or if they fit loosely in the hub.

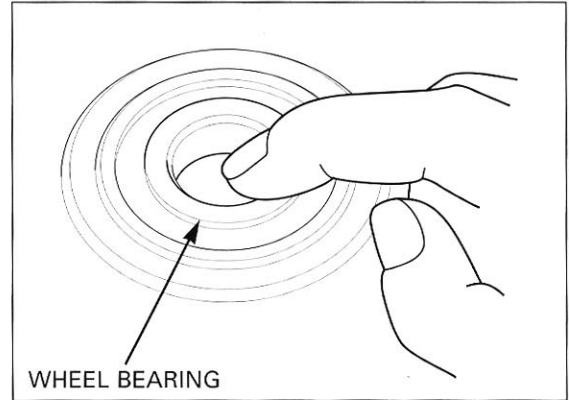

### WHEEL RIM RUN OUT

Check the rim runout by placing the wheel in a truing stand. Spin the wheel slowly and read the runout using a dial indicator. Actual runout is 1/2 the total indicator reading.

**SERVICE LIMITS:** Radial: 2.0 mm (0.08 in)  
Axial: 2.0 mm (0.08 in)

Check the spokes and tighten any that are loose.

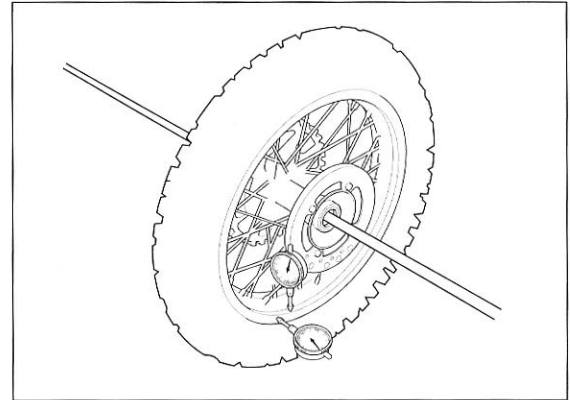

### DISASSEMBLY

Remove the bolts, nuts and brake disc.  
Remove the right dust seal.

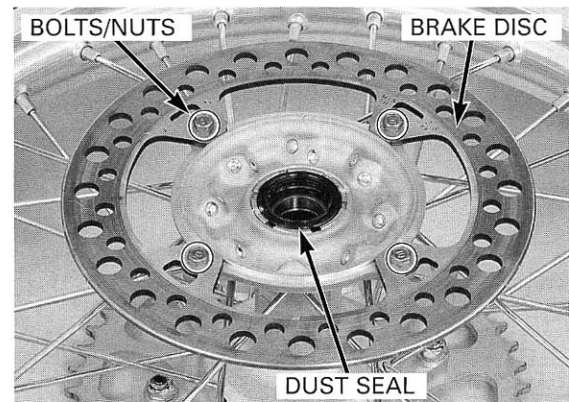

Remove the driven sprocket bolts, nuts and washers.  
Remove the driven sprocket.  
Remove the left dust seal.

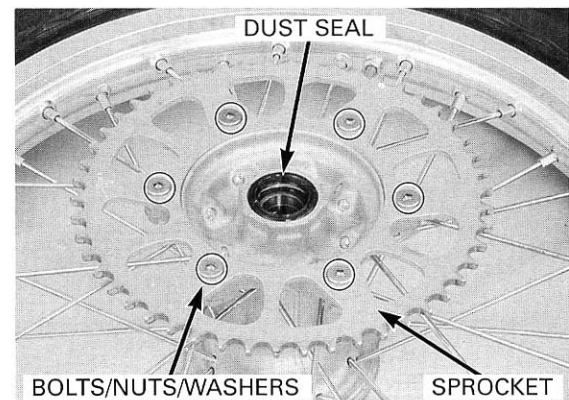

## REAR WHEEL/SUSPENSION

Remove the bearing retainer using the special tool as shown.

**TOOLS:**

**Retainer wrench 48 x 15 mm** 07YMA-KZ40100 or 07HMF-KS70100 (U.S.A. only)  
**Retainer wrench body** 07710-0010401

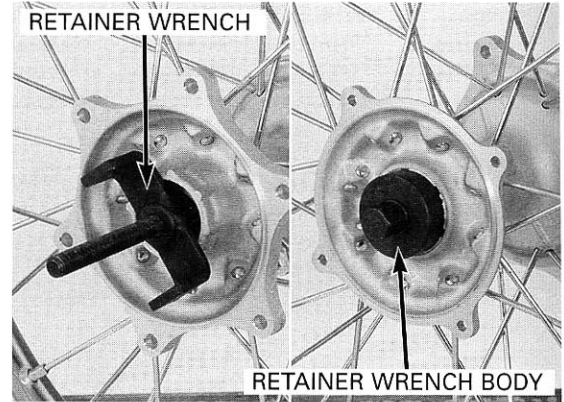

Remove the wheel bearings and distance collar.

**TOOLS:**

**Bearing remover head, 25 mm** 07746-0050800  
**Bearing remover shaft** 07746-0050100

- Never install the old bearings; once the bearings have been removed, they must be replaced with new ones.
- Replace the bearings in pairs.

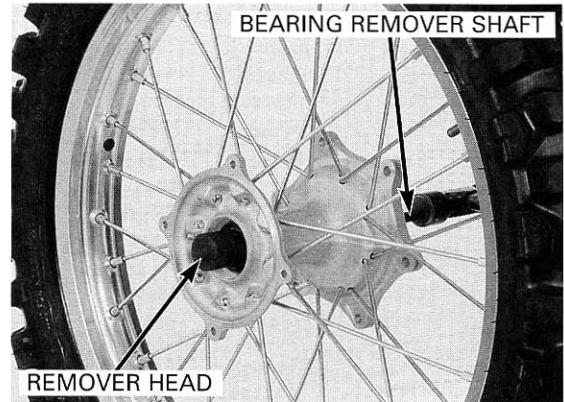

### ASSEMBLY

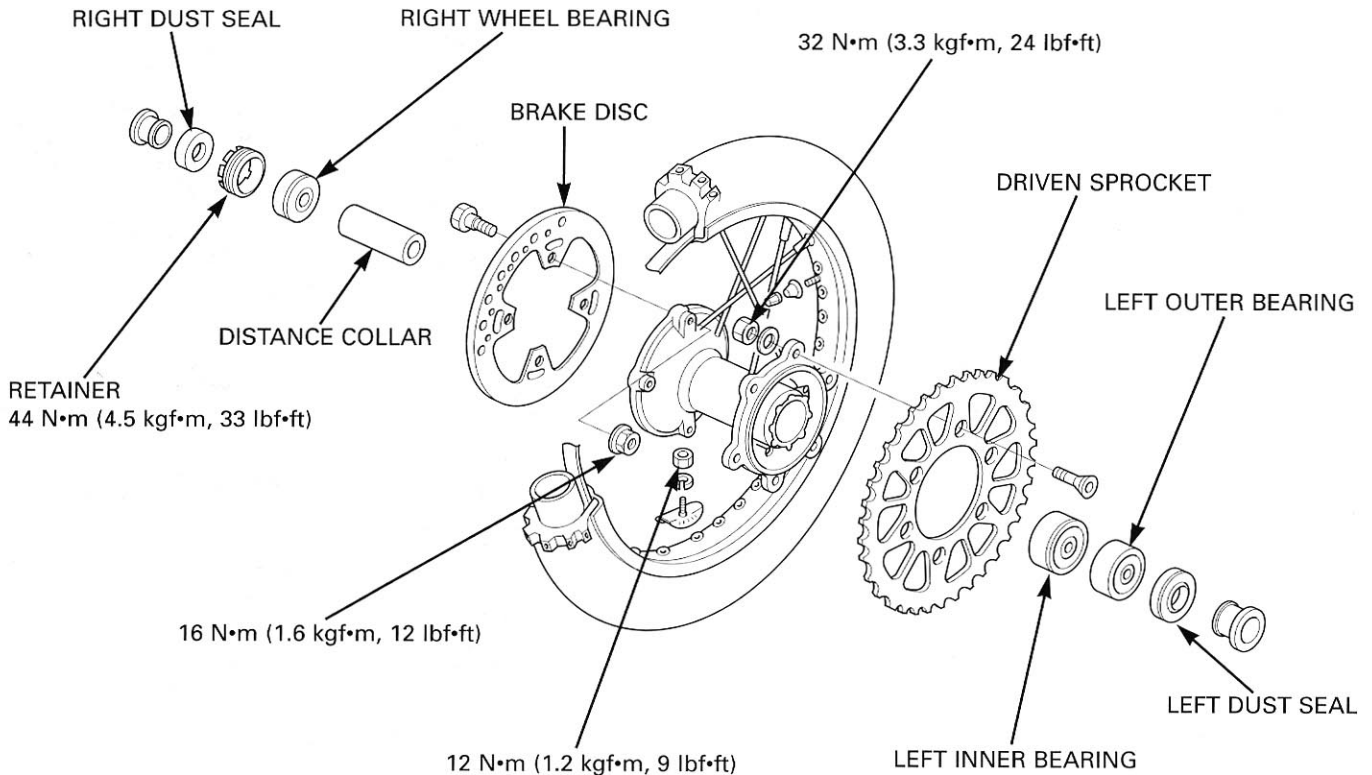

## REAR WHEEL/SUSPENSION

Place the rim on the work bench, with its directional arrow facing counterclockwise.

Place the hub in the center of the rim, and begin lacing with new spokes.

Adjust the hub position so the distance from the hub left end surface to the side of the rim is 45.5 mm (1.79 in) as shown.

Torque the spokes in two or three progressive steps.

**TOOL:**

**Spoke nipple wrench, 6.6** 070MA-KZ30100 or equivalent commercially available in U.S.A.

**TORQUE: 3.6 N·m (0.37 kgf·m, 2.7 lbf·ft)**

Install the rim lock, rim band, tube and tire.

Torque the rim lock to the specified torque.

**TORQUE: 12 N·m (1.2 kgf·m, 9 lbf·ft)**

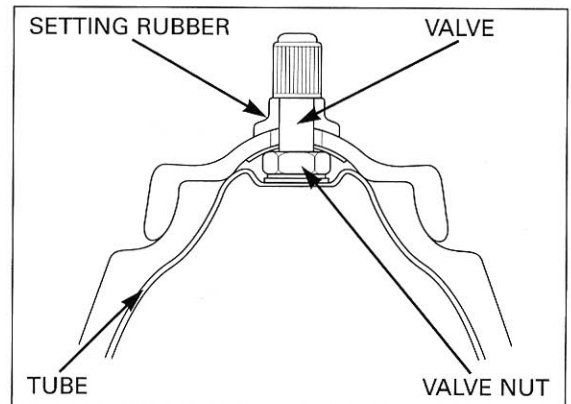
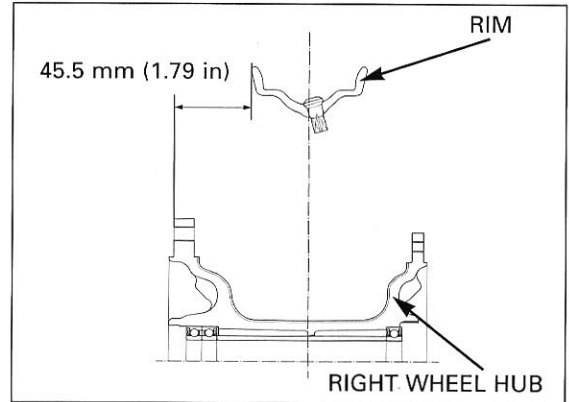

Pack the all bearing cavities with grease.

Drive in the new left bearing using the special tools as shown.

**TOOLS:**

**Driver** 07749-0010000  
**Attachment, 42 x 47 mm** 07746-0010300  
**Pilot, 25 mm** 07746-0040600

Install the distance collar, then drive in the new right side bearing using the same tools.

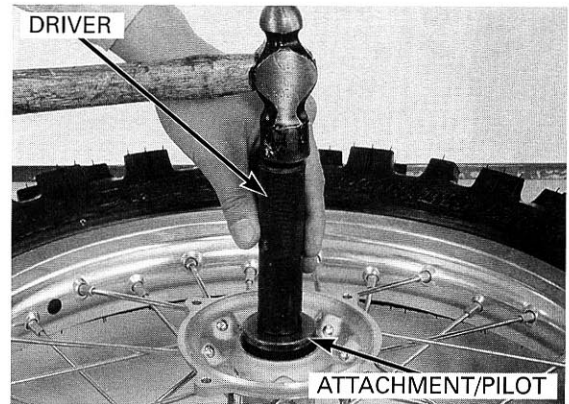

Apply grease to the bearing retainer and install it into the hub using the special tools.

**TOOLS:**

**Retainer wrench, 48 x 15 mm** 07YMA-KZ40100 or 07HMA-KS70100 (U.S.A. only)  
**Retainer wrench body** 07710-0010401

**TORQUE: 44 N·m (4.5 kgf·m, 33 lbf·ft)**

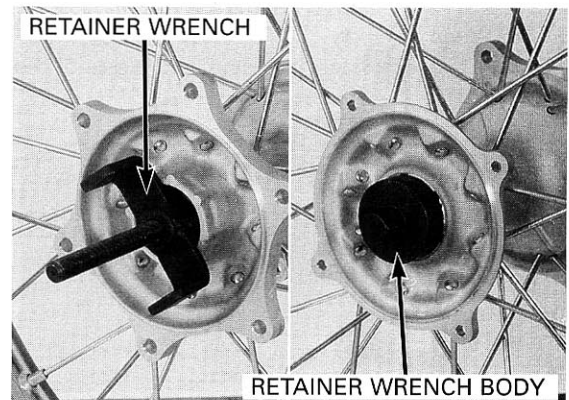



## REAR WHEEL/SUSPENSION

Peen the edge of the retainer.

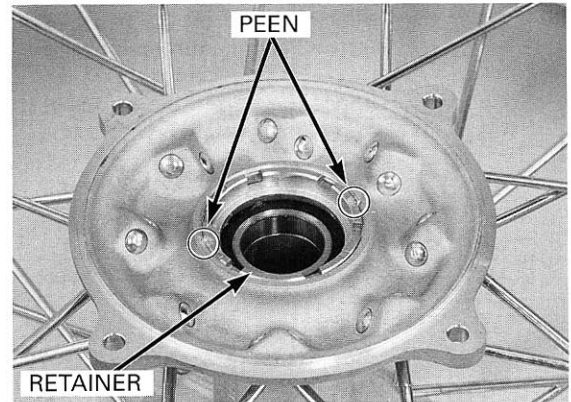

Install the driven sprocket.  
Install the bolts, washers and nuts, and tighten the nuts to the specified torque.

**TORQUE: 32 N·m (3.3 kgf·m, 24 lbf·ft)**

Apply grease to the new left dust seal lips, then install the seal.

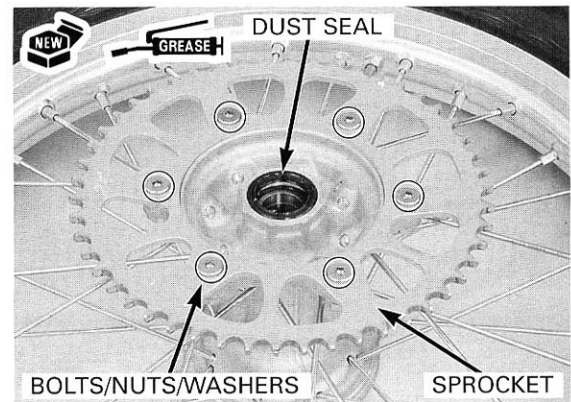

Install the brake disc with its "DRIVE" mark facing out.  
Install the bolts and tighten the nuts to the specified torque.

**TORQUE: 16 N·m (1.6 kgf·m, 12 lbf·ft)**

Apply grease to the new right dust seal lips, then install the seal.

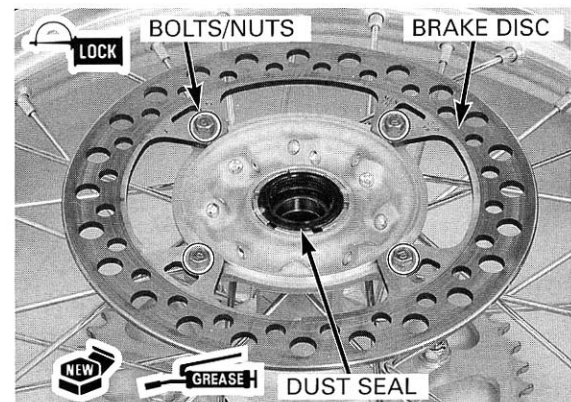

## INSTALLATION

Apply grease to the inside of the side collar.

Install the side collars.

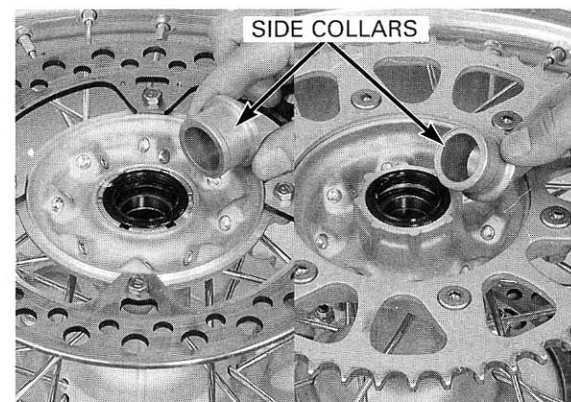

If the rear brake caliper bracket was removed, install it onto the slide rail of the swingarm.

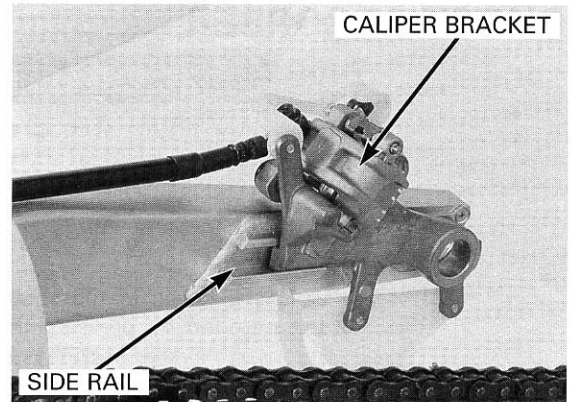

Place the rear wheel into the swingarm.  
Apply a thin coat of grease to the axle.  
Install the axle from the left side.  
Install the drive chain over the driven sprocket.

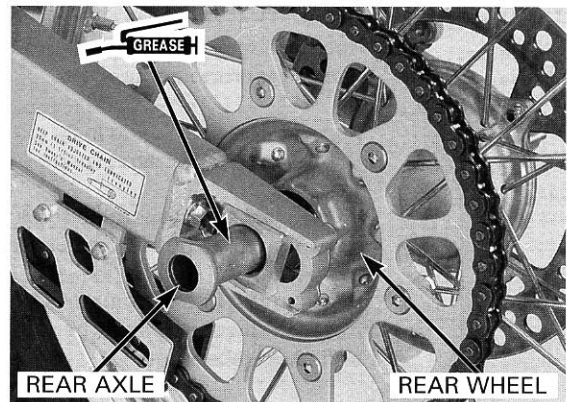

If the master link retaining clip was removed, install it on the drive chain with the closed end of the clip in the direction of wheel rotation.

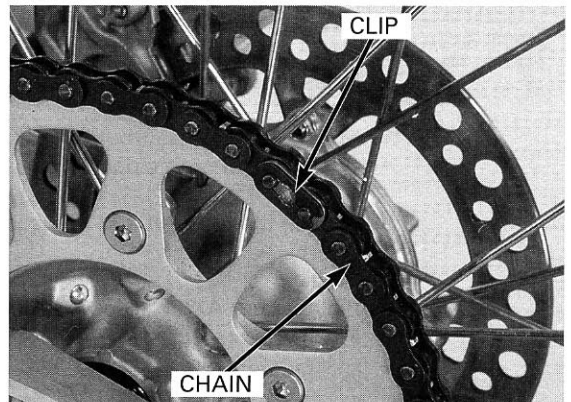

Install the washer and loosely install the axle nut.

Adjust the drive chain slack (page 3-11).

Tighten the axle nut to the specified torque.

**TORQUE: 127 N·m (13.0 kgf·m, 93 lbf·ft)**

Snug the adjusting bolts against the chain adjusters and tighten the lock nuts.

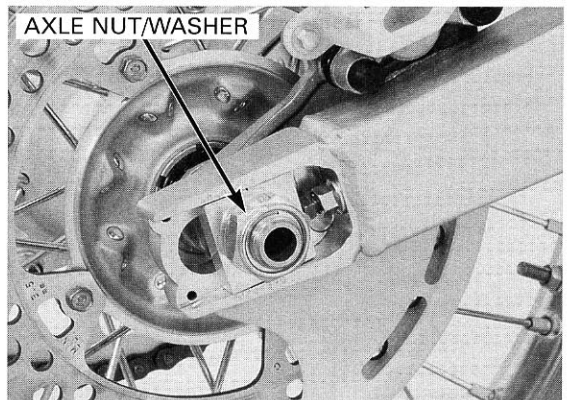

### SHOCK ABSORBER

#### ⚠ CAUTION

- Use only nitrogen to pressurize the shock absorber. The use of an unstable gas can cause a fire or explosion resulting in serious injury.
- The shock absorber contains nitrogen under high pressure. Do not allow fire or heat near the shock absorber.
- Before disposal of the shock absorber, release the nitrogen by pressing the valve core. Then remove the valve from the shock absorber.

#### REMOVAL

Raise the rear wheel off the ground by placing a work-stand under the engine.

Remove the seat (page 2-2).

Remove the sub-frame (page 2-3).

If you plan to disassemble the shock absorber, loosen the spring lock nut and adjusting nut.

Remove the upper mounting bolt/nut.  
Remove the shock absorber lower mounting bolt/nut and shock absorber.

#### DISASSEMBLY

Measure the spring length for installation later.

Hold the shock absorber in a vise by the upper mount, protected on both sides by pieces of wood.

Loosen the lock nut and adjusting nut.

#### TOOLS:

Pin spanner A      89201-KS6-810 (2 required) or  
Pin spanner      07702-0020001 (2 required)

Remove the stop ring, spring seat and spring.

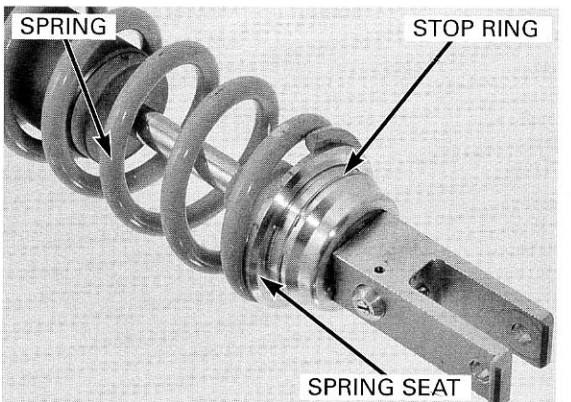
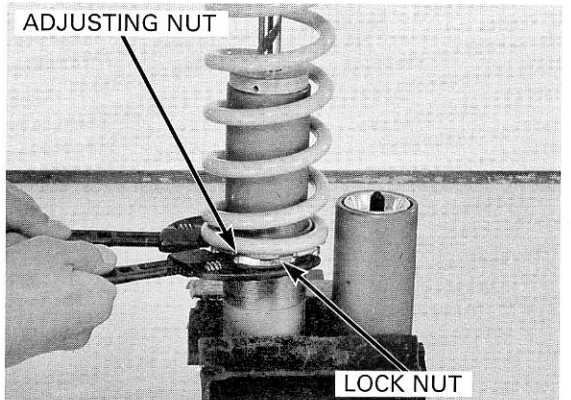
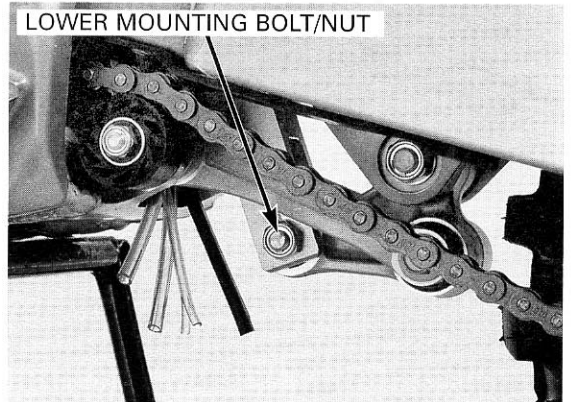
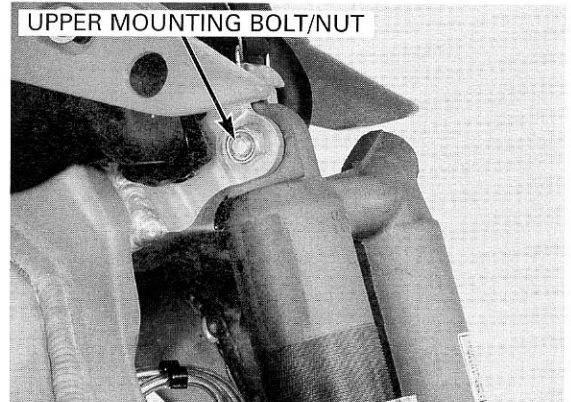

### BLADDER REPLACEMENT

Replace the bladder when oil leaks around the chamber cap or oil spills out when releasing the nitrogen from the reservoir.

Perform this procedure before draining the oil from the damper.

Depress the valve core to release the nitrogen from the reservoir.

**⚠ CAUTION**

- Release all nitrogen pressure before disassembly; otherwise the chamber cap will be under significant pressure and could cause serious injury or death.
- Wear protective clothing and adequate eye protection to prevent injury and from debris entering your eyes.

Remove the valve core.

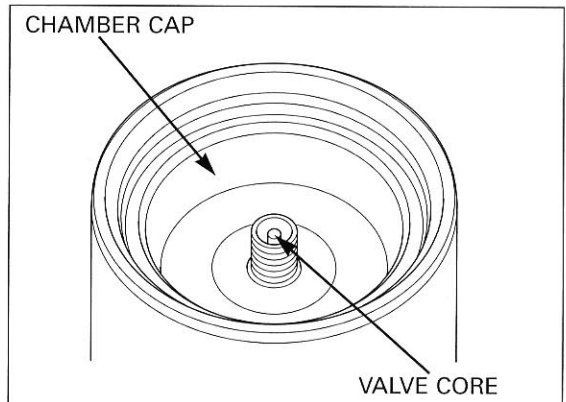
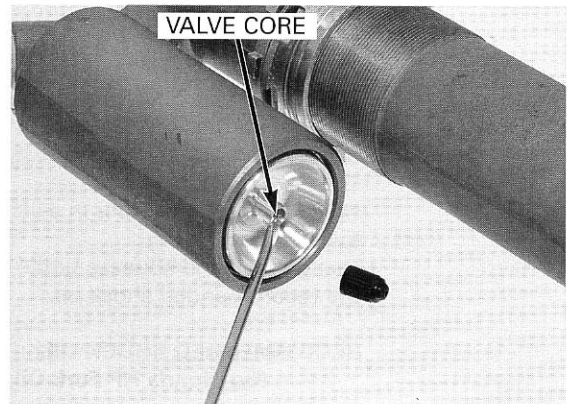

*To avoid damaging the threads of the gas valve, install the cap before depressing the chamber cap.*

Put a suitable tool on the valve cap and push it in by lightly tapping on the tool with a plastic hammer until you have good access to the stop ring.

Depress the chamber cap just the minimum amount necessary for stop ring access.

Two small screwdrivers and a shop towel are required to remove the stop ring.

The stop ring groove in the reservoir is ramped toward the inside to give the stop ring a square shoulder on which to seat securely.

*To avoid damaging the inside surfaces of the reservoir, cover the screwdriver with a shop towel.*

To remove the stop ring, first push one end of the stop ring out of its groove, then slip the second screwdriver between the stop ring and the reservoir to act as a ramp.

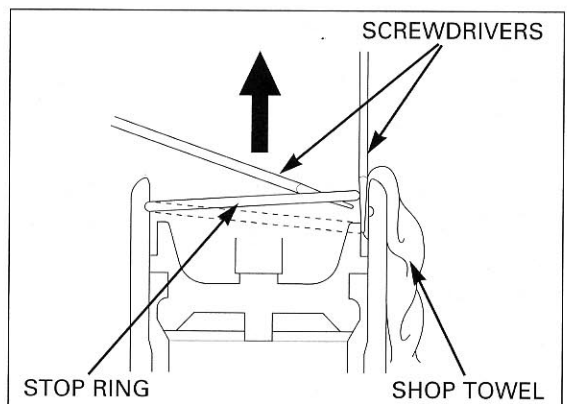
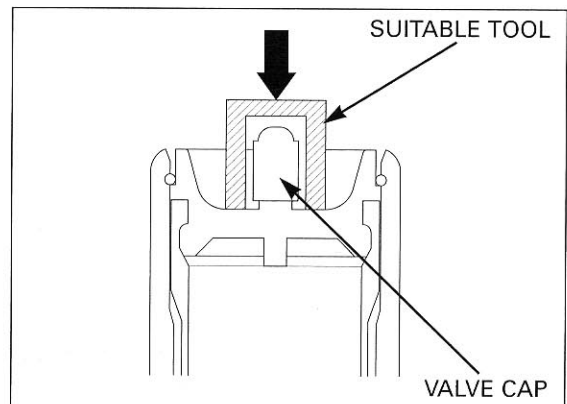

## REAR WHEEL/SUSPENSION

Now, use the other screwdriver to pull the stop ring completely out.

Check the stop ring groove for burrs. Remove any burrs with the fine emery cloth before pulling the damper rod out of the case.

Hold the shock absorber in a vise protected with shop towels or soft jaws.

Using a suitable squeeze bottle, fill the reservoir with the recommended shock oil.

### RECOMMENDED SHOCK OIL: Pro-Honda HP Fork Oil 5W

Slowly pump the damper rod until no air bubbles appear in the valve core hole, then pull the damper rod all the way out.

Install the valve core securely.

Wear protective clothing and a face guard to protect your eyes and face in case the chamber cap pops out quickly and forcibly.

Remove the chamber cap and bladder following the procedure below:

1. Wrap the shop towel around the chamber cap. Compress the damper rod slowly, to force the chamber cap out.

*The chamber cap will be removed with hydraulic pressure so its force can be significant considering the air in the bladder.*

2. Place the damper in a vise with soft jaws with the damping adjuster facing up, being careful not to distort the damper body. Remove the damping adjuster.

### NOTICE

*Do not overtighten the vise or the shock body will be damaged.*

3. Fill the damper with Pro-Honda HP Fork Oil 5W through the damping adjuster hole, while slowly pulling the damper rod out.

4. Reinstall the damping adjuster after filling the damper.

5. The damper must be kept upright to prevent oil from leaking out. Place the damper with the reservoir chamber cap facing up.

6. Repeat steps 1 to 5 until the chamber cap is removed from the reservoir.

Remove the bladder from the chamber cap.

Attach the new bladder to the chamber cap.

*Do not use any sort of tool to remove the bladder, because it may damage the chamber cap. Replace the bladder with a new one. Do not reuse the removed one.*

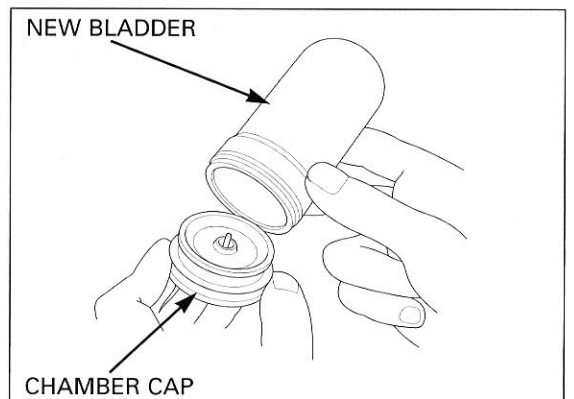
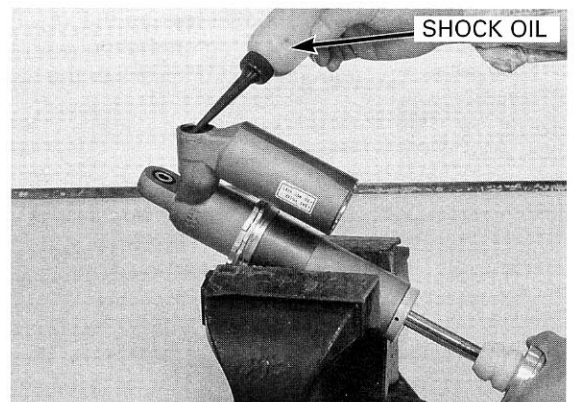
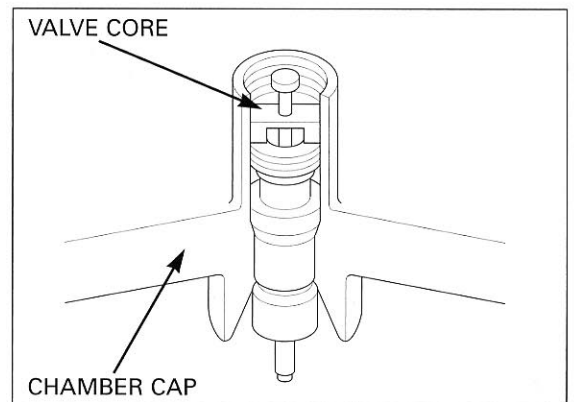
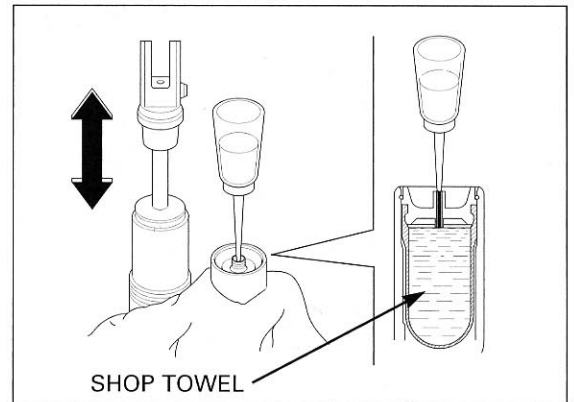

If the bladder becomes distorted during installation, depress the valve core to reform it.

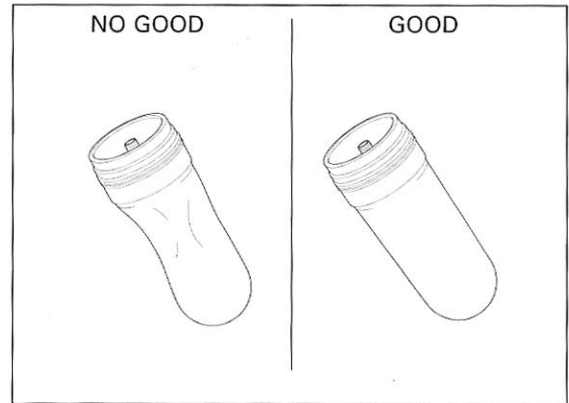

Clean the inside of the reservoir and fill it with Pro Honda HP Fork Oil 5W.

**RECOMMENDED SHOCK OIL:  
Pro Honda HP Fork Oil 5W**

Apply a light coat of shock oil to the lip of the bladder, and press the chamber cap into the reservoir to about 1 – 2 mm (0.04 – 0.08 in) below the stop ring groove.

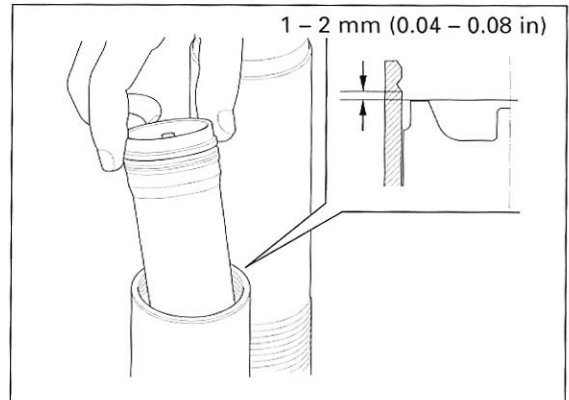

*Be sure the stop ring is seated in the ring groove all the way around or the chamber cap can come apart when riding the motorcycle.*

Install the stop ring in the groove of the reservoir securely. Temporarily fill the reservoir with air slowly until the chamber cap seats against the stop ring.

Make sure that the chamber cap face is level with the reservoir face.

If the chamber cap does not seat fully, the chamber cap may fly out when filling the reservoir with nitrogen.

Release the air from the reservoir by depressing the valve core.

Bleed the air from the shock absorber bladder (page 12-21).

Fill the reservoir with nitrogen to the specified pressure (page 12-21).

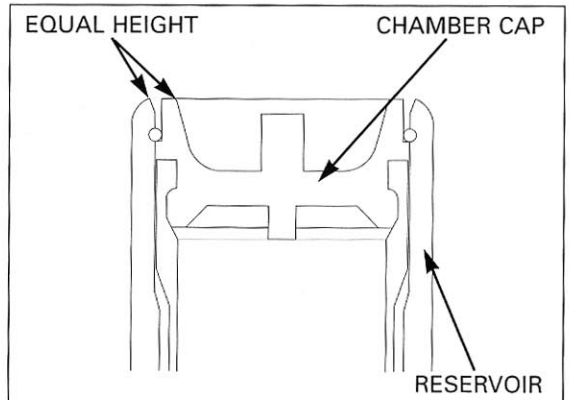

### DAMPER DISASSEMBLY

*Point the valve away from you to prevent debris getting in your eyes.*

Depress the valve core to release the nitrogen from the reservoir (page 12-11).

Before disposal of the shock absorber, release the nitrogen by pressing the valve core. Then remove the valve from the shock absorber.

Remove the damping adjuster.

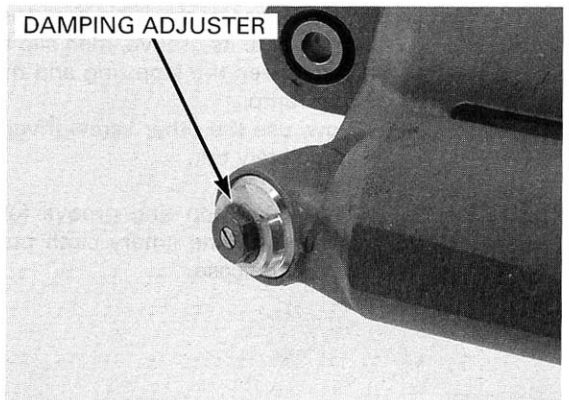

## REAR WHEEL/SUSPENSION

Drain most of the shock oil from the damper and reservoir, by pumping the damper rod in and out several times.

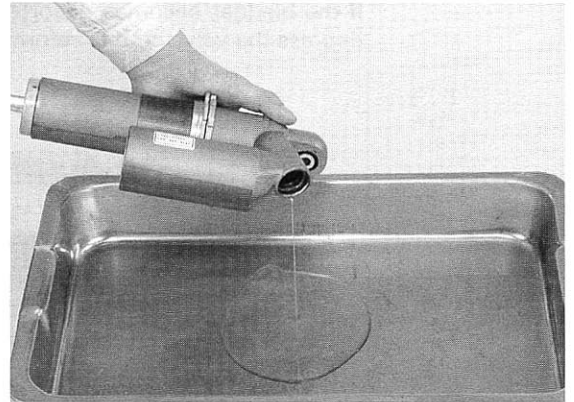

Clamp the shock absorber in a vise by the damper case. Place two pieces of wood on each side of the shock to protect it.

Remove the end plate and tape or tie it to the rubber stopper so it will not get in the way.

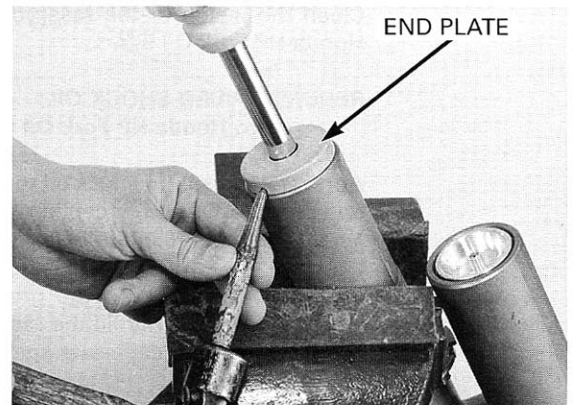

Push in the damper seal until you have good access to the stop ring.

Two small screwdrivers are required to remove the stop ring. The stop ring groove in the damper case is ramped towards the inside to give the stop ring a square shoulder on which to seat securely.

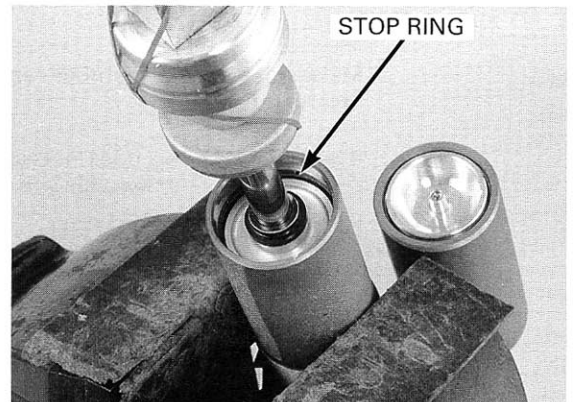

To remove the stop ring, first push one end of the stop ring out of its groove, then slip the second screwdriver between the stop ring and the damper case to act as a ramp.

Now, use the other screwdriver to pull the stop ring completely out.

*Burrs will damage the damper rod piston ring.*

Check the stop ring groove for burrs. Remove any burrs with fine emery cloth pulling the damper rod out of the case.

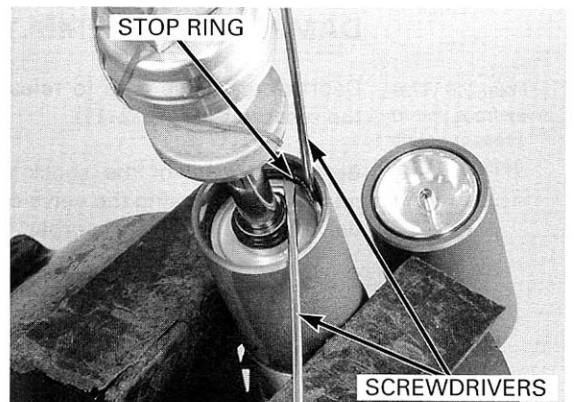

Carefully pull the damper rod assembly out of the damper case.

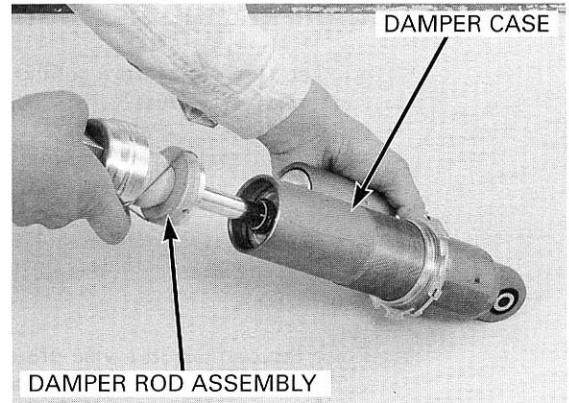

### PISTON RING REPLACEMENT

Inspect the piston ring.  
If the piston ring is damaged, cut the piston ring and replace the piston ring and O-ring under the piston ring with a new one.

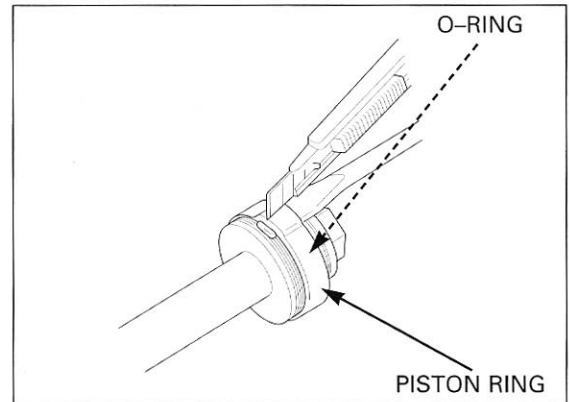

Place the slider guide attachment over the piston and install a new O-ring and piston ring into place by hand.

**TOOL:**  
**Slider guide attachment**      **070MO-KZ30100 not available in U.S.A.**

Compress the piston ring against the ring groove and seat the piston ring into the ring groove.

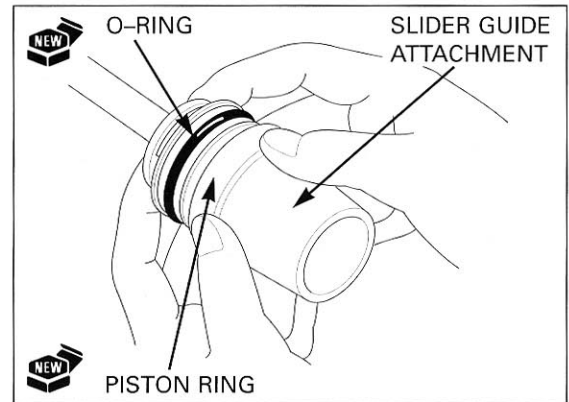



### DAMPER ROD DISASSEMBLY

- To keep lint or dirt from getting onto the damper rod parts, do not wear gloves while working on the damper rod.
- Be careful to grind the end nut so that the O.D. of the rod end is about 10 mm (0.4 in). Be careful not to over-file.

Unstake the damper rod end nut with a grinder as shown.

Place the damper in a vise protected with a piece of wood or shop towel, being careful not to distort the lower mount.

Turn the end nut back-and-forth in 1/4 turn increments until it loosens, then rotate another 1/4 turn and repeat turning back-and-forth until the nut loosens completely. Discard the nut.

Hold the lower shock mount in a vise with soft jaws, a piece of wood, or shop towel.

*Clean thoroughly with solvent. If the threads cannot be repaired, replace the rod.*

Remove all the burrs from the end of the damper rod end with a file and correct the threads with a die.

**DIE: 12 x 1.25 mm**

If the damper rod is cracked or damaged when removing the end nut, replace the damper rod assembly with a new one.

Clean the damper rod with solvent after correcting the threads.

Make sure that filings are not stuck in the damper rod.

Remove the valve stopper, rebound valves and piston from the damper rod.

- Use a piece of mechanic's wire to keep the removed valves in the correct order.
- Keep dust and abrasives away from all damper rod parts.
- Thoroughly clean the valves in solvent and blow them dry with compressed air if they have been disassembled and separated.
- Be careful not to get solvent on the O-ring and piston ring.
- The valve arrangement and number of valves shown is typical and may not represent this model exactly.

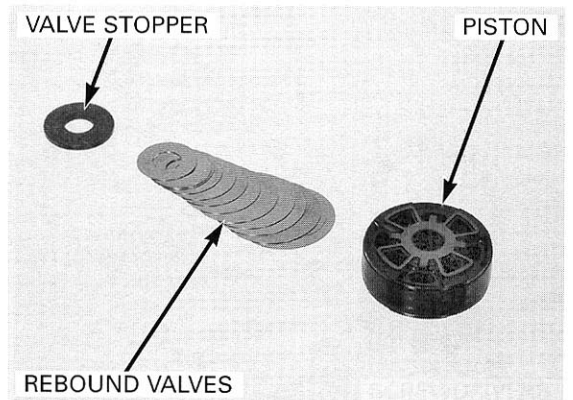
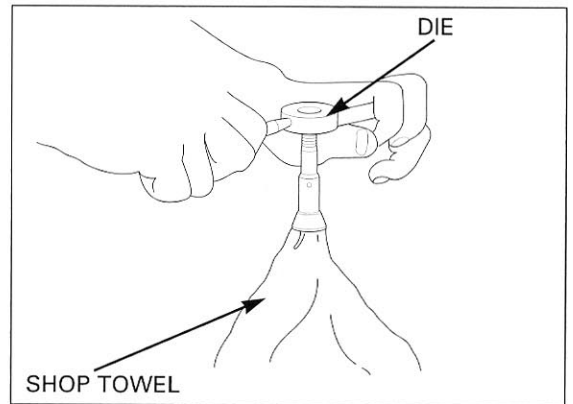
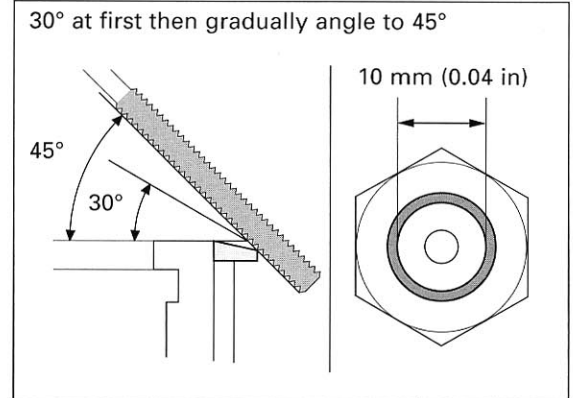

Remove the compression valves and valve stopper.

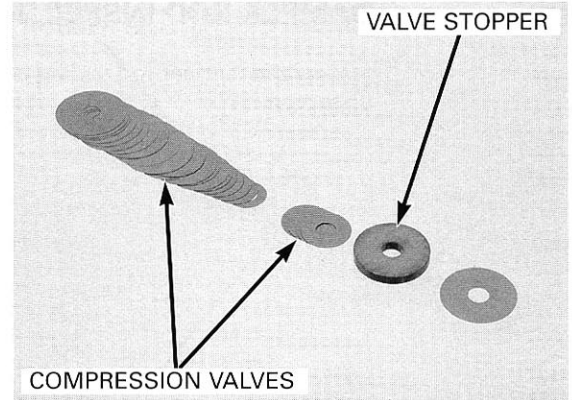

Wrap the top threads of the damper rod with tape.

Remove the spring and rod guide case from the damper rod.

Remove the end plate, rubber stopper and rubber seat from the damper rod.

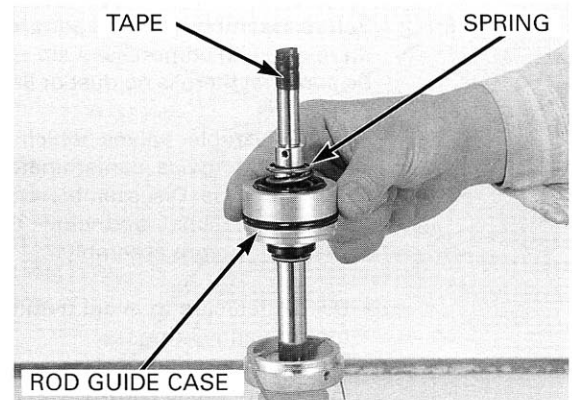

### ROD GUIDE INSPECTION

Inspect the rebound rubber and dust seal lips for wear or damage and replace the rod guide case with a new one if necessary.

Visually inspect the rod guide case metal. If the metal is worn so that the copper surface appears, replace the rod guide case with a new one.

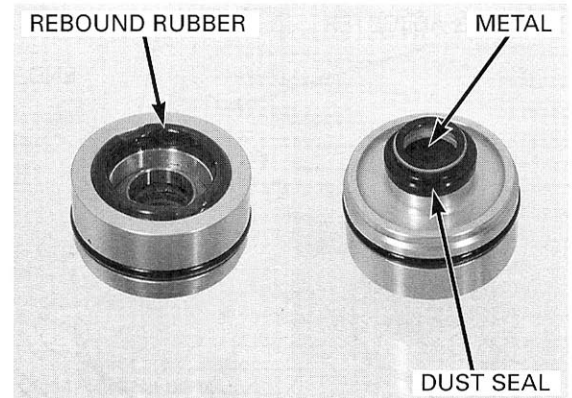

Remove the O-ring from the rod guide case and replace it with a new one.

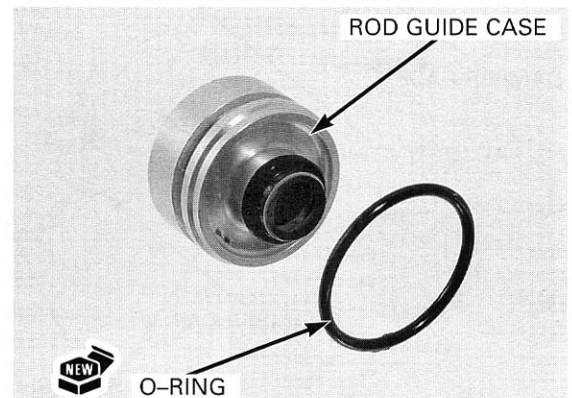

## REAR WHEEL/SUSPENSION

### DAMPER ROD INSPECTION

Inspect the damper rod sliding surface for damage or distortion.

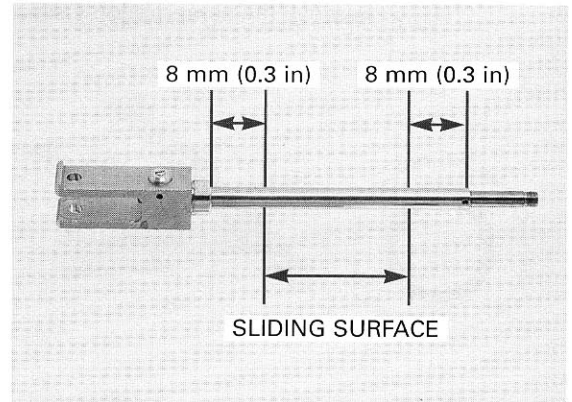

### DAMPER ASSEMBLY

Before assembly, wash all parts with solvent and blow them dry with compressed air. Be sure that there is no dust or lint on any of the parts.

Never assemble valves which might have gotten dusty or otherwise contaminated during the disassembly process. Disassemble them, thoroughly clean them with solvent and blow them dry with compressed air before assembly.

- Use added care to avoid getting solvent on the piston ring and O-ring.
- The valve arrangement and number of valves may differ from those shown.

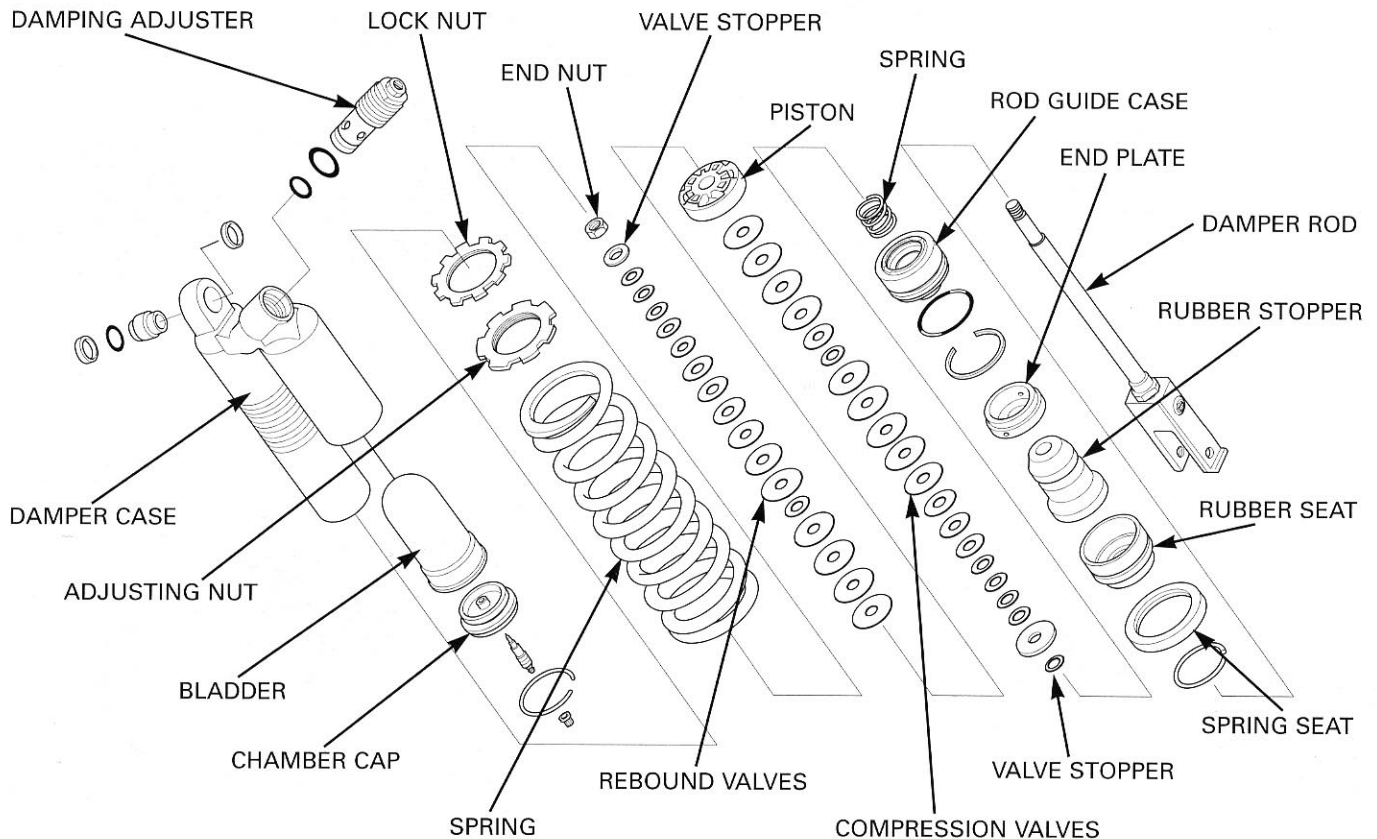
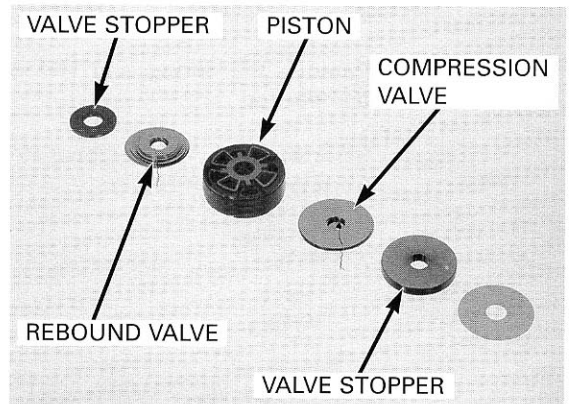

Install the rubber seat, rubber stopper and end plate.

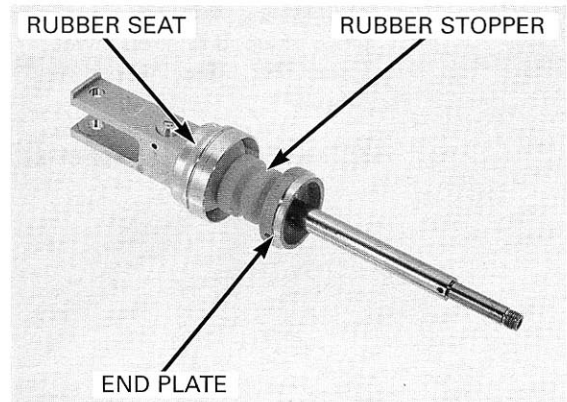

Install the special tool onto the damper rod.

**TOOL:**

**Slider guide, 16 mm**

**07PMG-KZ40100 not available in U.S.A.**

- The rod guide case oil seal is filled with grease.
- Be careful not to remove grease from the seal.

*Be careful not to damage the dust seal lip or turn it inside out.*

Carefully install the rod guide case with the rebound rubber facing up, over the damper rod. Install the rod guide case spring.

Remove the special tool.

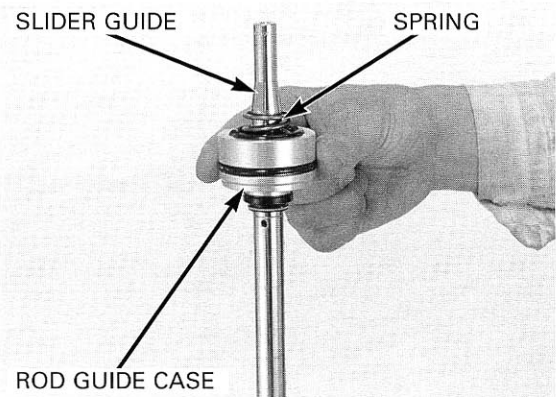

*The valve arrangement and number of valves may vary from those shown.*

Install the valve stopper and compression valves onto the damper rod.

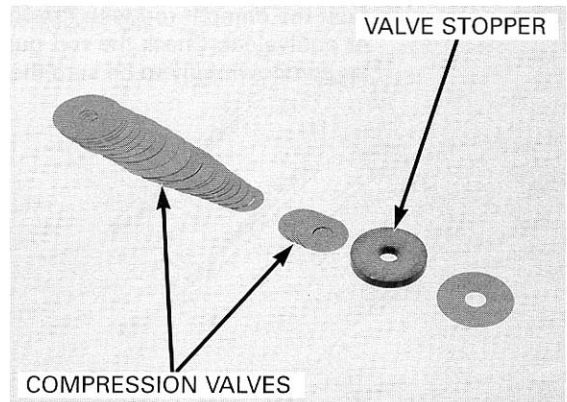

*Note the installation direction of the piston valves. Be careful not to bind the valves when installing the piston onto the damper rod. Also, check that they are concentric with the damper rod.*

Install the piston onto the damper rod.

Install the rebound valves with their polished surfaces facing down. Install the valve stopper.

Do not install the end washer unless you're using a new damper rod.

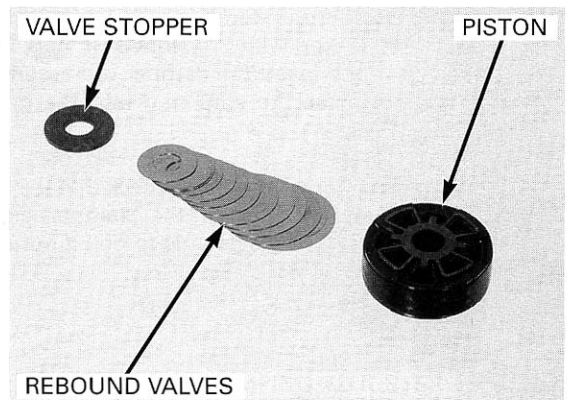

## REAR WHEEL/SUSPENSION

Hold the lower shock mount in a vice with soft jaws, a piece of wood or shop towel. Install and tighten a new end nut to the specified torque.

**TORQUE: 37 N·m (3.8 kgf·m, 27 lbf·ft)**

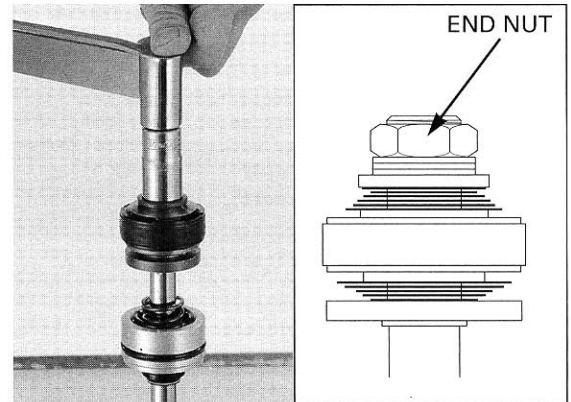

Stake the end of damper rod in three places as shown to secure the end nut.

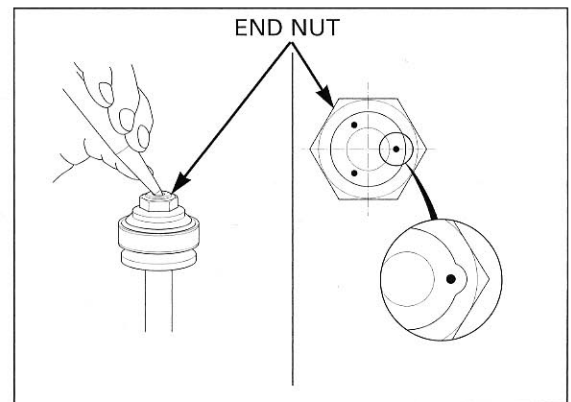

Coat the damper rod with Pro Honda HP Fork Oil 5W or equivalent. Check the rod guide case by sliding it up and down fully to be sure there is no restriction.

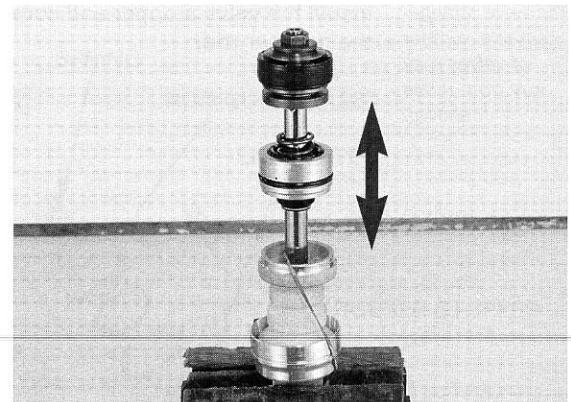

Coat the damper case inner surface, piston ring and O-ring with Pro Honda HP Fork Oil 5W or equivalent, and insert the damper rod assembly carefully. Install the stop ring into the groove in the damper case.

After assembling, check that the stop ring is seated in the groove of the damper case completely. You should not be able to pull it out of the damper case.

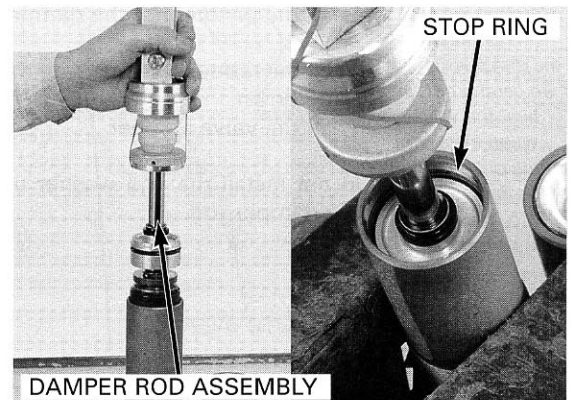

*Do not overtighten the vise and distort the damper case.*

Hold the shock absorber gently in a vise by the damper case, protected on both sides by pieces of wood.

Drive the end plate squarely and evenly into the damper case with a plastic hammer.

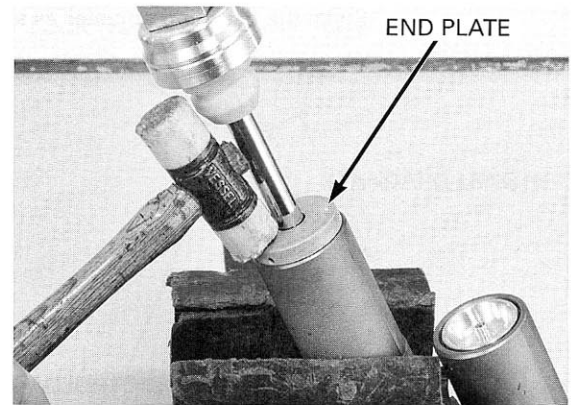

Fill the damper case and reservoir with Pro Honda HP Fork Oil 5W through the damping adjuster hole.

**RECOMMENDED SHOCK OIL:**  
**Pro Honda HP Fork Oil 5W or equivalent**

Make sure the rod guide case is seated against the stop ring by pulling the damper rod out all the way.

Slowly pump the damper rod until there are no bubbles in the oil that overflows from the damper case.

Remove the damper unit from the vise.

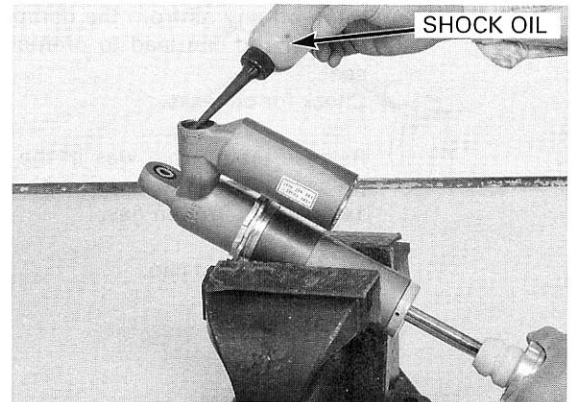

*When bleeding air from the reservoir, be careful to hold the damper at the angles shown so the filler hole points up.*

Position the damper so the damping adjuster hole faces up. Turn the damper unit as shown to bleed any air from the reservoir completely. Do not let oil flow out of the reservoir.

Temporarily charge the reservoir with 49 kPa (0.5 kgf/cm<sup>2</sup>, 7.1 psi) of air slowly to inflate the bladder.

Check for any oil that may leak out of the valve while pressurizing. Replenish oil as necessary. Be sure the reservoir pressure is correct using an accurate pressure gauge.

Fill the damper with the Pro Honda HP Fork Oil 5W to the damping adjuster hole neck.

Apply oil to the new O-rings and install them to the damping adjuster.

Dip the damping adjuster in clean shock oil.

Slowly install the damping adjuster.

Tighten the damping adjuster to the specified torque.

**TORQUE: 29 N·m (3.0 kgf·m, 22 lbf·ft)**

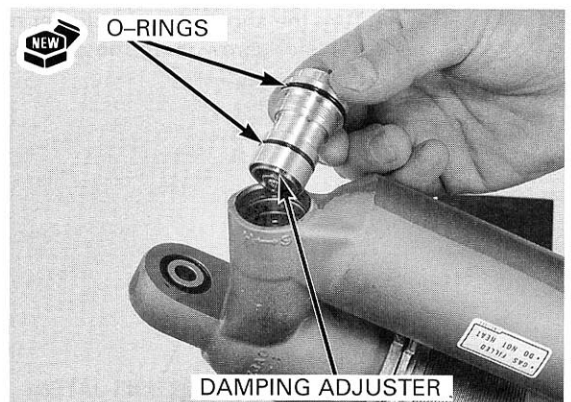
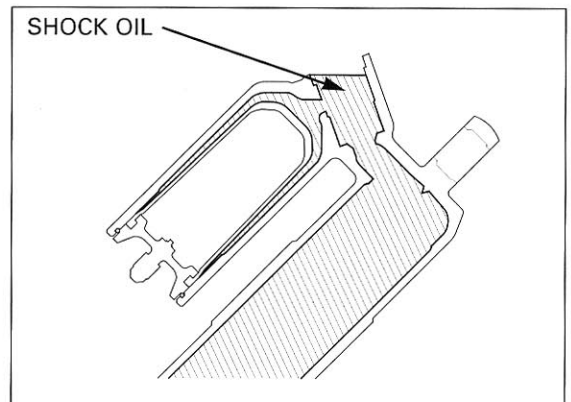

## REAR WHEEL/SUSPENSION

Stake the damping adjuster as shown.

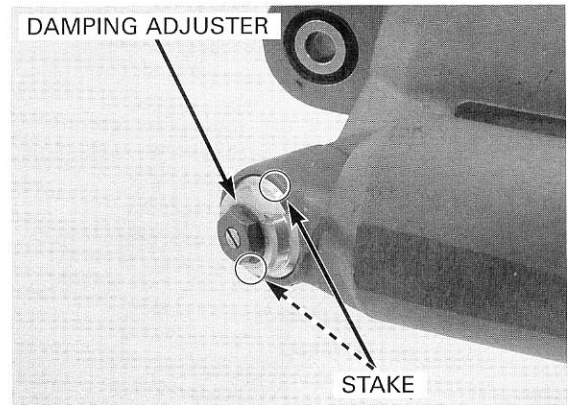

Wipe off any oil from the damper rod; oil left on the damper rod can lead to premature failure of the oil seal.

Check for oil leaks.

Release the air that was in the reservoir at precompression. Fill the reservoir with 981 kPa (10.0 kgf/cm<sup>2</sup>, 142 psi) of nitrogen gas.

Install the valve cap.

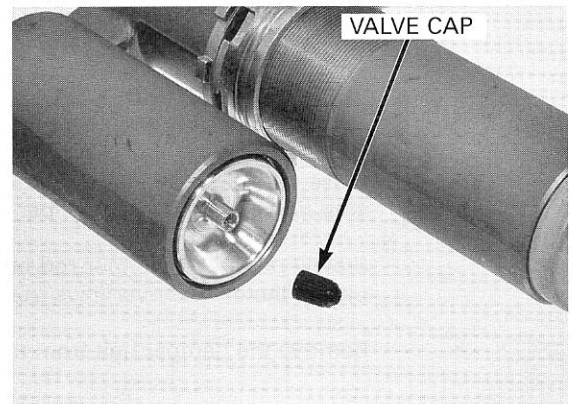

Install the spring, spring seat and stop ring.

Temporarily tighten the adjusting nut and lock nut.

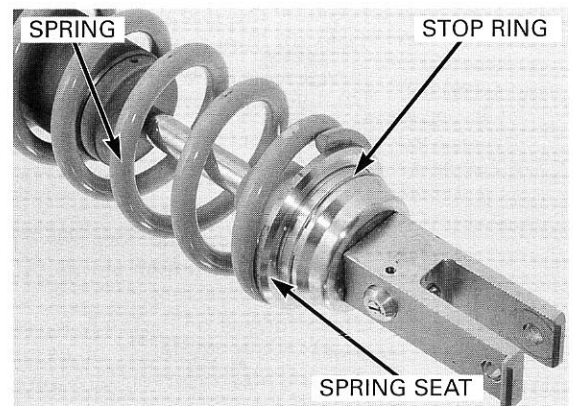

Turn the shock absorber lower mount so the rebound adjuster screw is on the same side of the shock and reservoir.

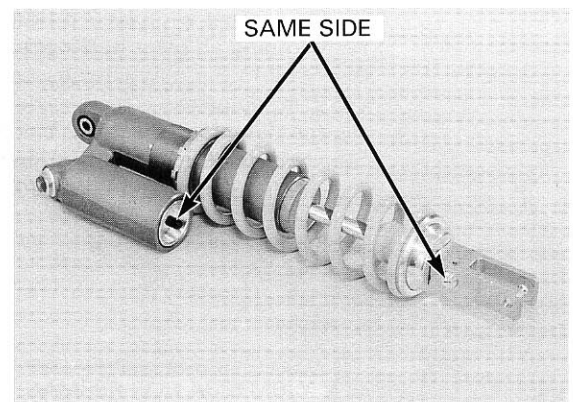

*One turn of the adjusting nut changes the spring length by 1.5 mm (0.06 in).*

Turn the spring adjusting nut until the spring length measurement recorded at disassembly is reached or until the spring length is as specified below.

**STANDARD SPRING LENGTH: 265 mm (10.43 in)**

Hold the adjusting nut and tighten the lock nut.

**TORQUE: 44 N·m (4.5 kgf·m, 33 lbf·ft)**

Use this standard spring length as the baseline. See the Owner's Manual for detailed instructions on adjusting preload and damping setting for rider weight and setting damping for riding conditions and rider skill.

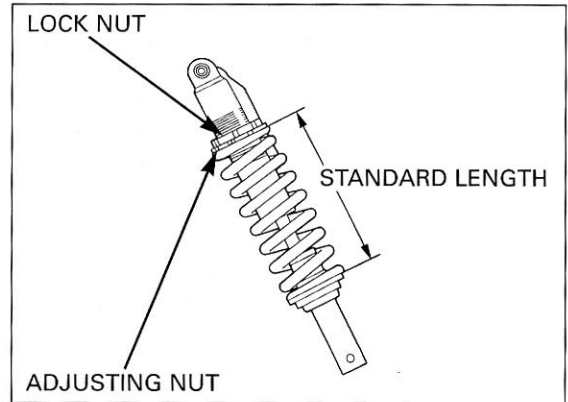

**SPHERICAL BEARING REPLACEMENT**

Check the spherical bearing for wear or damage. If it is worn or damaged, it must be replaced.

Remove the dust seals.

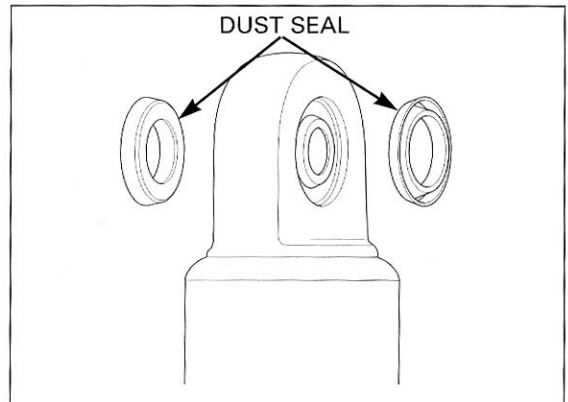

Press the spherical bearing to get the clearance necessary to remove the stop ring.

**TOOL:**  
**Spherical bearing driver                      07946-KA30200**

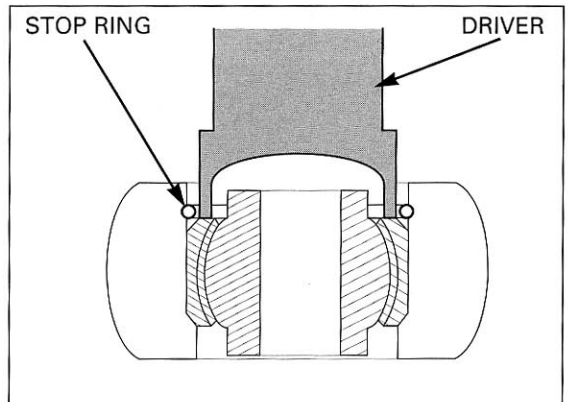

Press the spherical bearing out of the upper mount.

**TOOL:**  
**Spherical bearing driver                      07946-KA30200**

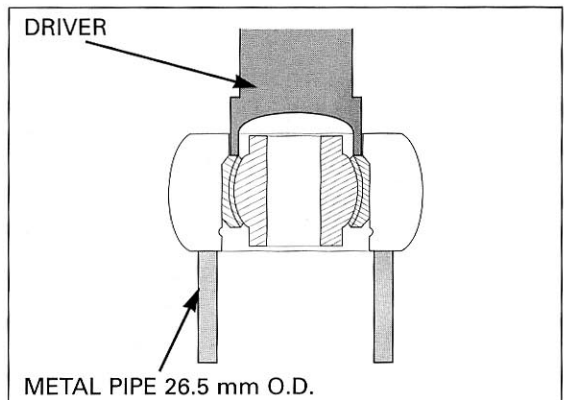



## REAR WHEEL/SUSPENSION

Apply multi-purpose grease NLGI No.2 (Molybdenum disulfide MoS<sub>2</sub> additive) to the new spherical bearing.

*Drive the bearing in evenly; do not allow it to tilt.*

Press a new spherical bearing into the upper mount.

**TOOL:**  
**Spherical bearing driver**                      **07946-KA30200**

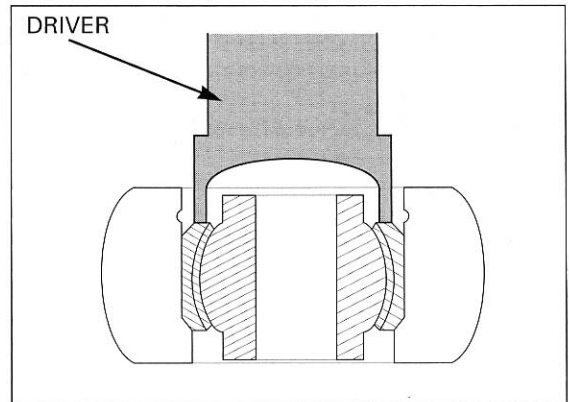

Install a new stop ring into the groove of the upper mount securely.  
Press the spherical bearing into the upper mount until it seats against the stop ring.

**TOOL:**  
**Spherical bearing driver**                      **07946-KA30200**

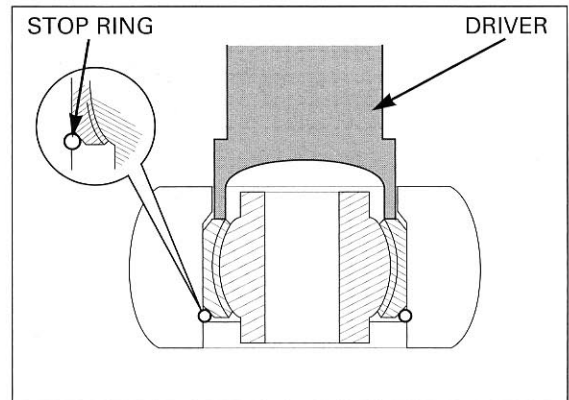

*Be sure to install the correct dust seal in each side.*

Apply grease to the lip of the new dust seals and install them.

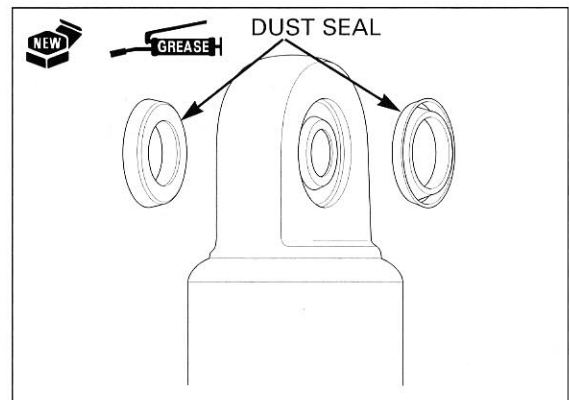

## INSTALLATION

Set the shock absorber onto the shock arm with the rebound adjuster facing to the right.  
Install the lower mounting bolt aligning the flat-side of the bolt with the stopper on the shock absorber.

Install and tighten the lower mounting nut.

**TORQUE: 44 N·m (4.5 kgf·m, 33 lbf·ft)**

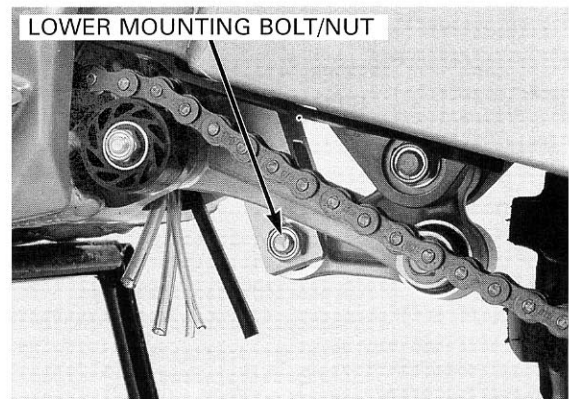

Install and tighten the shock absorber upper mounting nut/bolt.

**TORQUE: 44 N·m (4.5 kgf·m, 33 lbf·ft)**

Install the sub-frame (page 2-4).

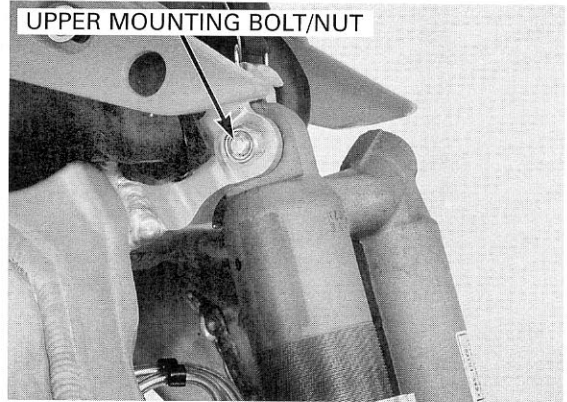

UPPER MOUNTING BOLT/NUT

## SHOCK LINKAGE

### REMOVAL

Remove the nut and drive chain roller.

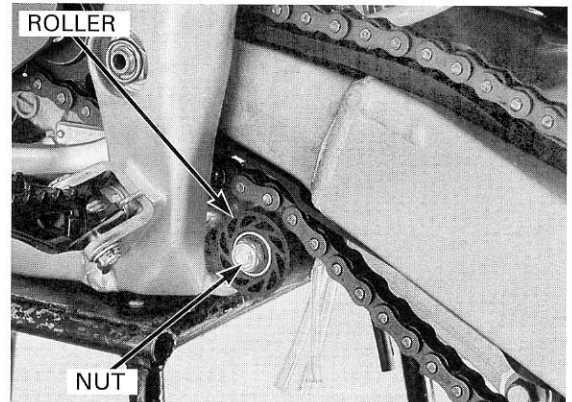

ROLLER

NUT

Remove the following:

- Shock absorber lower mounting bolt/nut
- Shock arm bolt/nut (shock link side)
- Shock arm bolt/nut (swingarm side)
- Shock arm
- Shock link bolt/nut (frame side)
- Shock link

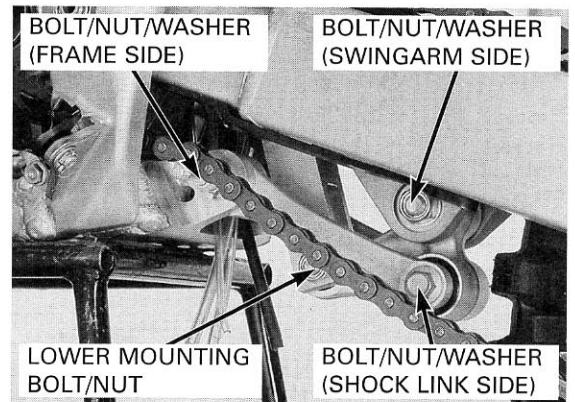

BOLT/NUT/WASHER (FRAME SIDE)

BOLT/NUT/WASHER (SWINGARM SIDE)

LOWER MOUNTING BOLT/NUT

BOLT/NUT/WASHER (SHOCK LINK SIDE)

Remove the side collars, pivot collar and dust seals from the shock link.

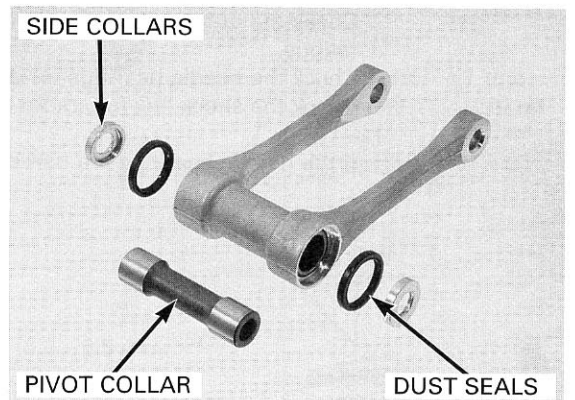

SIDE COLLARS

PIVOT COLLAR

DUST SEALS

## REAR WHEEL/SUSPENSION

Remove the pivot collars and side collars from the shock arm (swingarm side, shock link side).

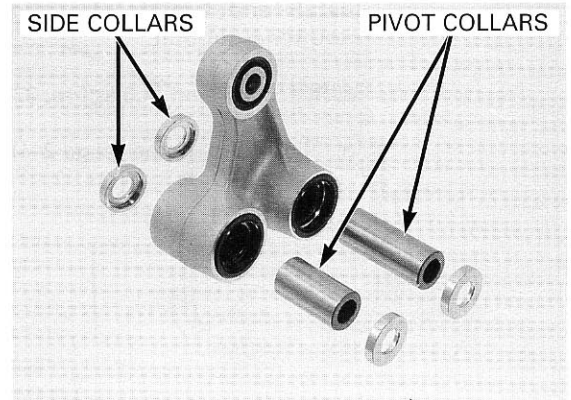

Remove the dust seals and washers (swingarm side, shock link side).

Remove the dust seals, side collars and pivot collar (shock absorber side).

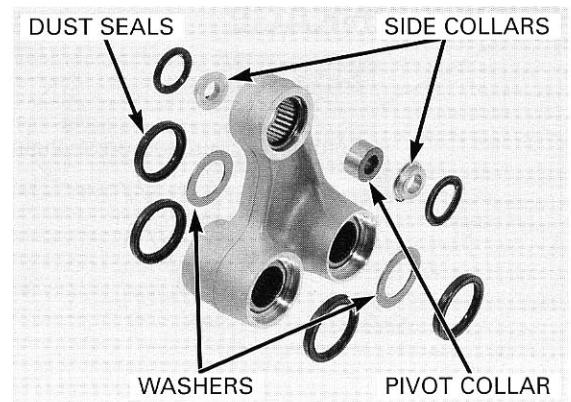

### INSPECTION

Check the dust seals and collars for wear, damage or fatigue.  
Check the needle bearings for damage or loose fit.  
Check the shock arm for cracks or damage.

If the needle bearings are damaged, replace them.

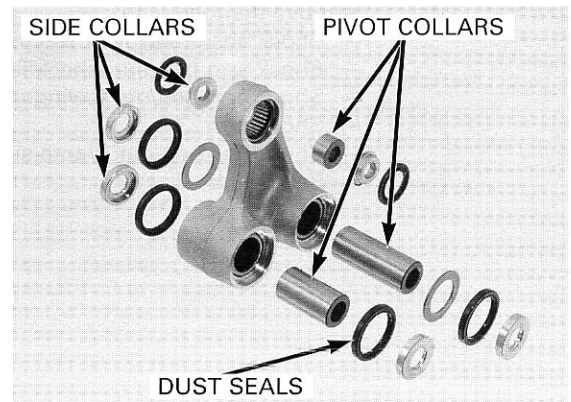

Check the dust seals and collars for wear, damage or fatigue.  
Check the needle bearings for damage or loose fit.  
Check the shock link for cracks or damage.

If the needle bearings are damaged, replace them.

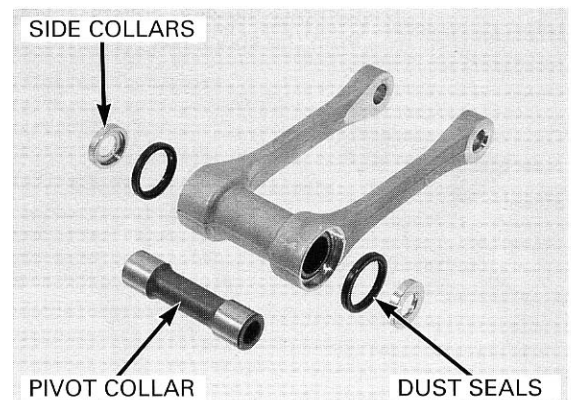

**BEARING REPLACEMENT**

**SHOCK ARM NEEDLE BEARING**

Press the needle bearings (shock link side, swingarm side) out of the shock arm using the special tools and a hydraulic press.

**TOOLS:**

**SHOCK LINK SIDE AND SWINGARM SIDE:**

**Driver** 07949-3710001  
**Attachment, 24 x 26 mm** 07746-0010700  
**Pilot, 20 mm** 07746-0040500

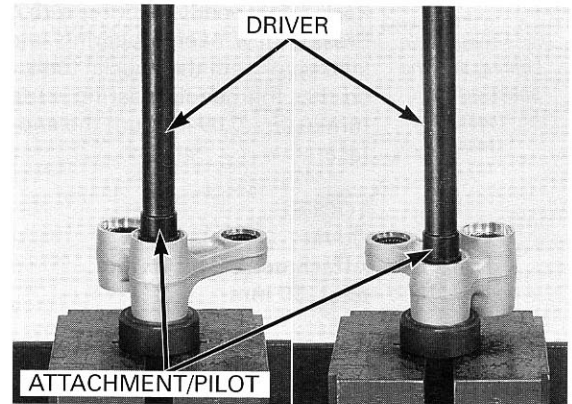

Press the needle bearing (shock absorber side) out of the shock arm using the special tools and a hydraulic press.

**TOOLS:**

**Driver** 07749-0010000  
**Attachment, 24 x 26 mm** 07746-0010700  
**Pilot, 19 mm** 07746-0041400

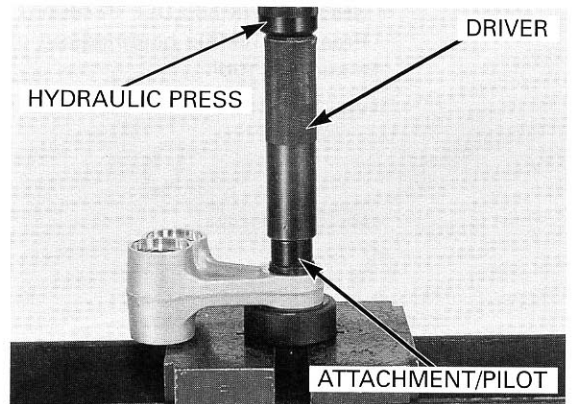

Pack the new needle bearings with multi-purpose grease.

*Press the needle bearing into the shock arm with the marked side facing out.*

Press the new needle bearings into the shock link side pivot with the special tools and a hydraulic press so that the needle bearing surface is lower 6.0 – 6.5 mm (0.23 – 0.26 in) from the end of the shock arm surface.

**TOOLS:**

**Driver** 07749-0010000  
**Attachment, 28 x 30 mm** 07746-1870100  
**Pilot, 20 mm** 07746-0040500

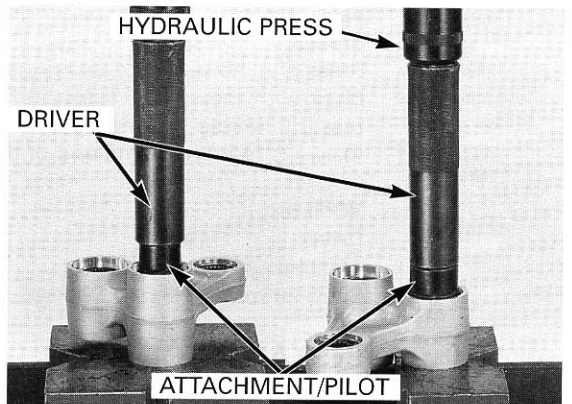

Pack the new needle bearings with multi-purpose grease.

*Press the needle bearing into the swingarm side pivot with the marked side facing out.*

Press the new needle bearings into the swingarm side pivot with the special tools and a hydraulic press so that the needle bearing surface is lower 4.4 – 4.7 mm (0.17 – 0.19 in) from the end of the shock arm surface.

**TOOLS:**

**Driver** 07749-0010000  
**Attachment, 28 x 30 mm** 07746-1870100  
**Pilot, 20 mm** 07746-0040500

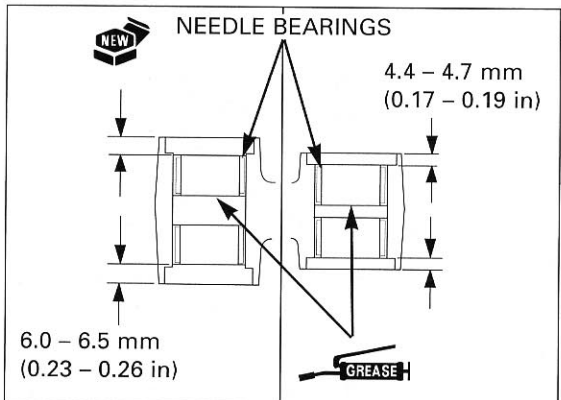

## REAR WHEEL/SUSPENSION

*Press the needle bearing into the shock arm with the marked side facing out.*

Pack a new needle bearing with multi-purpose grease. Press a new needle bearing into the shock absorber side pivot with the special tools and a hydraulic press so that the needle bearing surface is lower 2.0 – 2.2 mm (0.08 – 0.09 in) from the end of the shock arm surface.

### TOOLS:

**Driver** 07749-0010000  
**Attachment, 24 x 26 mm** 07746-0010700  
**Pilot, 19 mm** 07746-0041400

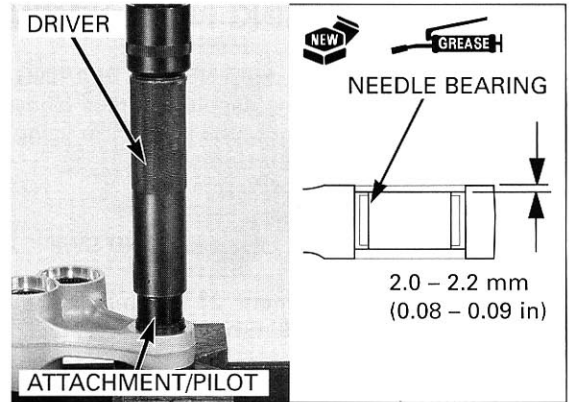

### SHOCK LINK NEEDLE BEARING

Press the needle bearings out of the shock link using a suitable tool.

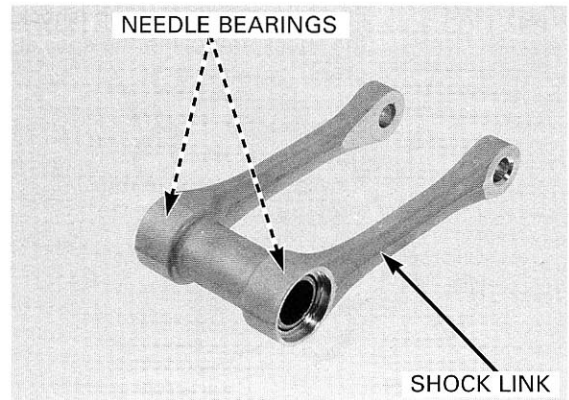

*Press the needle bearing into the shock link with the marked side facing out.*

Pack the new needle bearings with multi-purpose grease.

Press the new needle bearings into the shock link pivot with the special tools and a hydraulic press so that the needle bearing surface is lower 4.4 – 4.7 mm (0.17 – 0.19 in) from the end of the shock link surface.

### TOOLS:

**Driver** 07749-0010000  
**Attachment, 28 x 30 mm** 07746-1870100  
**Pilot, 20 mm** 07746-0040500

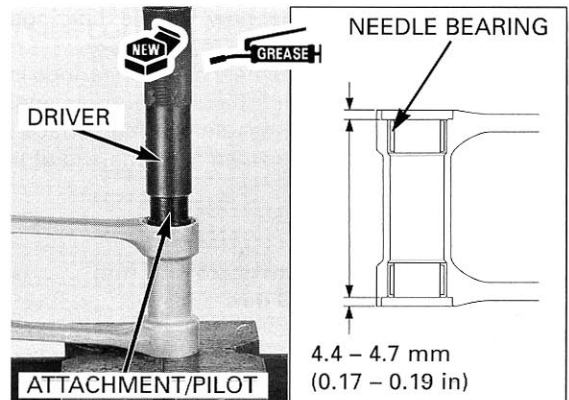

## INSTALLATION

Apply multi-purpose grease NLGI No.2 (molybdenum disulfide additive) to the shock arm, dust seal lips, collars and bearings.

Make sure the needle bearing rollers are in position before installing.

Number of needle rollers:  
 shock link side: 36  
 swingarm side: 36  
 shock absorber side: 36

Install the dust seals and washers to the shock arm (swingarm side, shock link side).

Install the dust seals, side collars and pivot collar to the shock arm (shock absorber side).

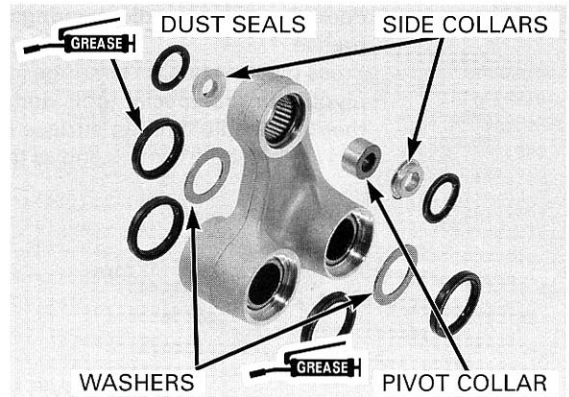

Install the pivot collars and dust seals to the shock arm (swingarm side, shock link side).

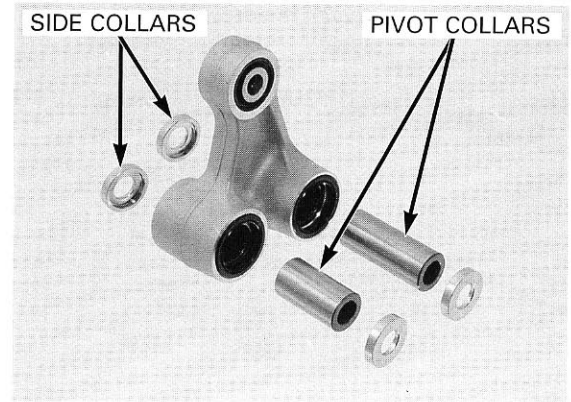

Apply multi-purpose grease NLGI No.2 (molybdenum disulfide additive) to the shock link, dust seal lips, collars and bearings.

Make sure the needle bearing rollers are in position before installing.

Number of needle rollers: 36

Install the dust seal, pivot collar and side collars to the shock link.

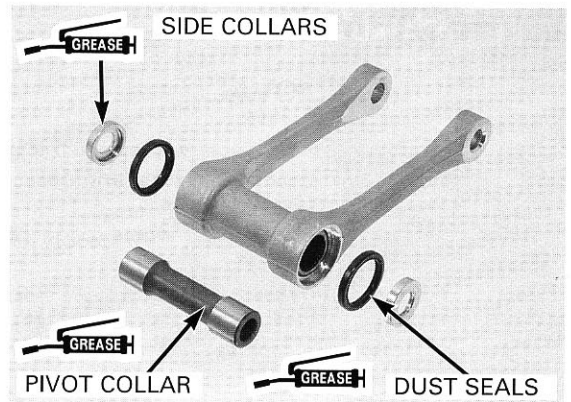

Apply oil to the shock arm nut threads and flange surface.

Temporarily install the following:

- Shock link
- Shock link bolt/nut/washer
- Shock arm
- Shock arm bolt/nut/washer (swingarm side)
- Shock arm bolt/nut/washer (shock link side)

Install the lower mounting bolt aligning the flat-side of the bolt with the stopper on the shock absorber.

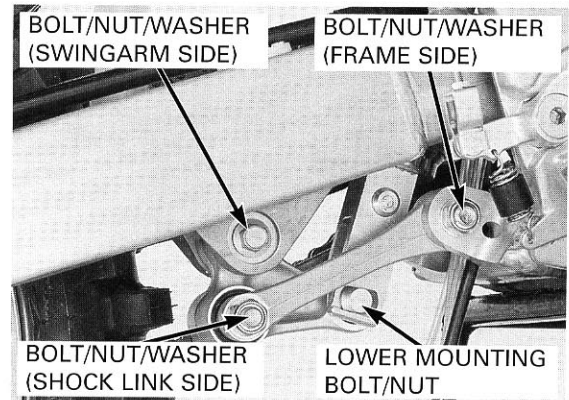

Tighten all nuts to the specified torque.

### TORQUE:

- Shock link nut:** 79 N·m (8.1 kgf·m, 59 lbf·ft)
- Shock arm nut (swingarm side):** 79 N·m (8.1 kgf·m, 59 lbf·ft)
- Shock arm nut (shock link side):** 79 N·m (8.1 kgf·m, 59 lbf·ft)
- Shock absorber lower mounting nut:** 44 N·m (4.5 kgf·m, 33 lbf·ft)

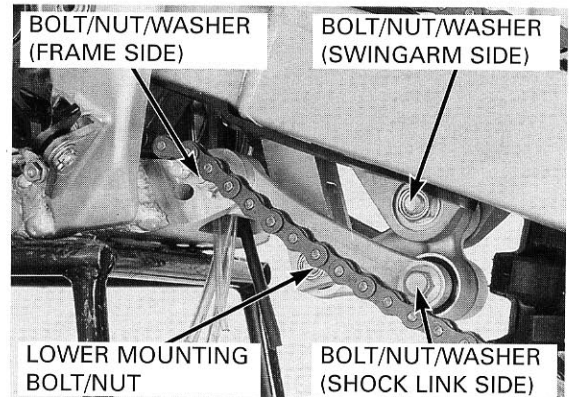

## REAR WHEEL/SUSPENSION

Install the drive chain roller with the arrow facing out. Install and tighten the nut to the specified torque.

**TORQUE: 12 N·m (1.2 kgf·m, 9 lbf·ft)**

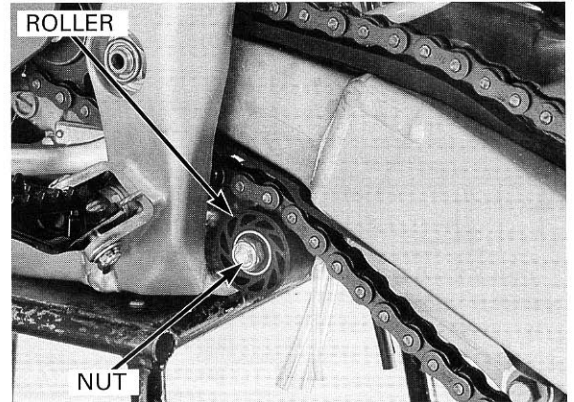

## SWINGARM

### REMOVAL

Raise the rear wheel off the ground by placing a workstand under the engine.

Remove the rear wheel (page 12-4).

Remove the shock arm bolt and nut (swingarm side).



Remove the screws and rear brake hose guide.

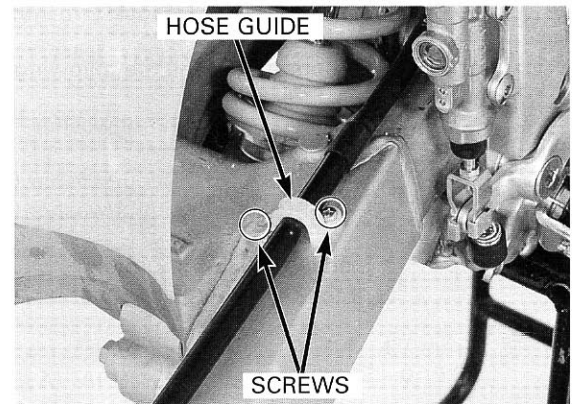

*Do not suspend the brake caliper from the brake hose. Do not twist the brake hose.*

Remove the rear brake caliper from the slide rail on the swingarm.

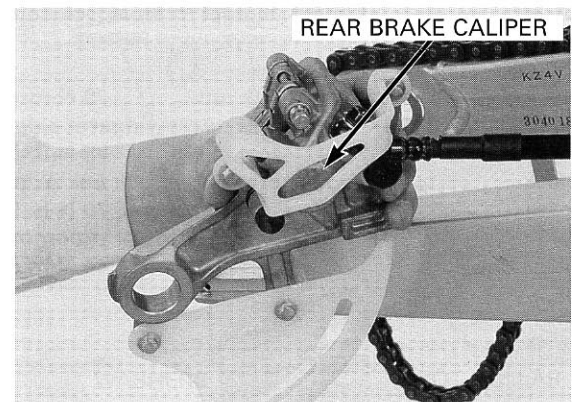

Remove the swingarm pivot nut.

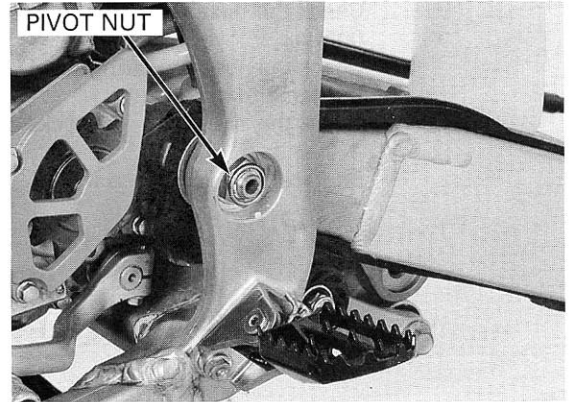

Remove the swingarm pivot bolt and swingarm.

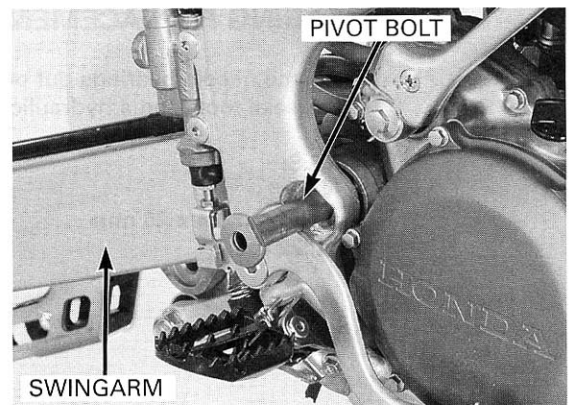

Check the chain slider and chain guide for wear or damage (page 3-12).

### DISASSEMBLY

Remove the bolts, nuts and chain guide.  
Remove the screws and chain slider.

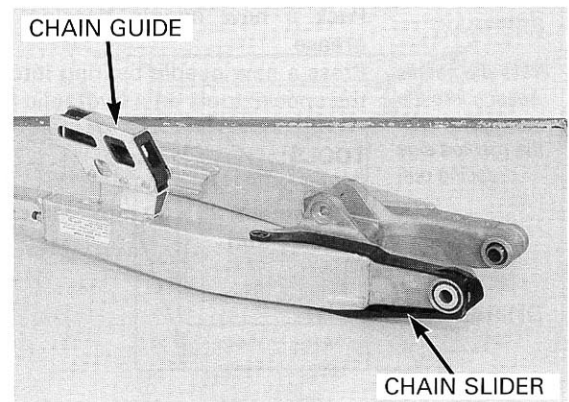

Remove the following:  
— Side collars  
— Dust seals  
— Washers  
— Thrust needle bearings  
— Collars

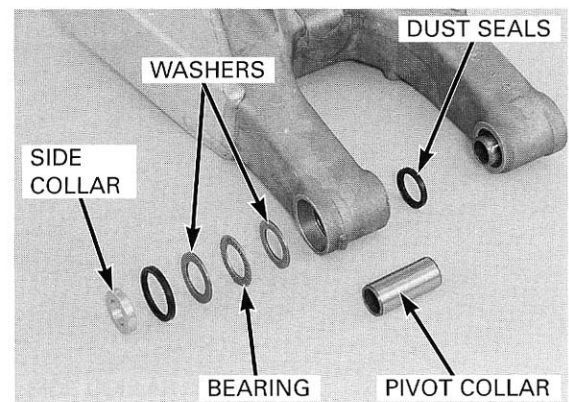



## REAR WHEEL/SUSPENSION



Check the dust seals and collars for wear, damage or fatigue.

Check the needle bearings and thrust needle bearings for damage or loose fit.

Check the swingarm for cracks or damage.

Replace them, if necessary.

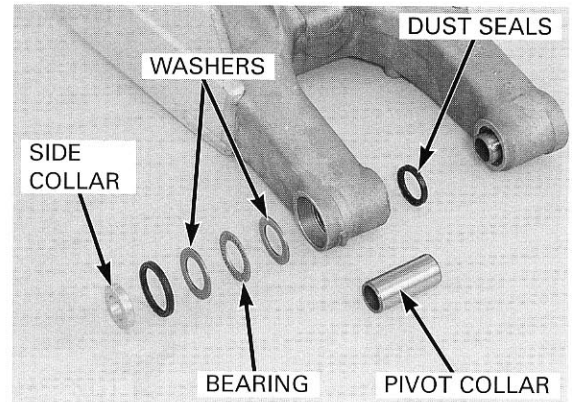

### BEARING REPLACEMENT

Press the needle bearings out of the swingarm using the special tools and a hydraulic press.

**TOOLS:**

<b>Driver</b>	<b>07949-3710001</b>
<b>Attachment, 24 x 26 mm</b>	<b>07746-0010700</b>
<b>Pilot, 22 mm</b>	<b>07746-0041000</b>

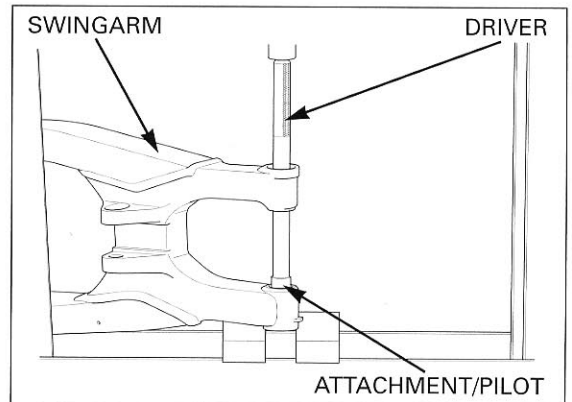

Pack a new needle bearing with multi-purpose grease.

Press a new needle bearing into the swingarm using the special tools and a hydraulic press as shown.

*Press the needle bearing into the swingarm with the marked side facing out.*

**TOOLS:**

<b>Driver</b>	<b>07749-0010000</b>
<b>Attachment, 28 x 30 mm</b>	<b>07746-1870100</b>
<b>Pilot, 22 mm</b>	<b>07746-0041000</b>

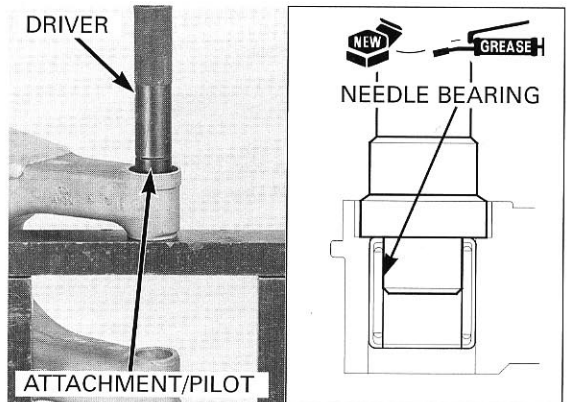

ASSEMBLY

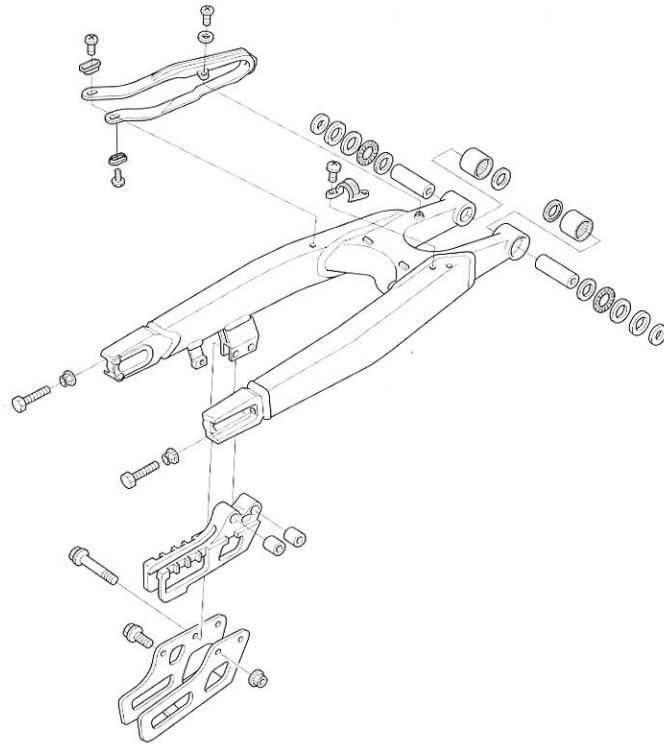

- Install the following:
- Washers
  - Thrust needle bearings
  - Dust seals
  - Collars
  - Side collars

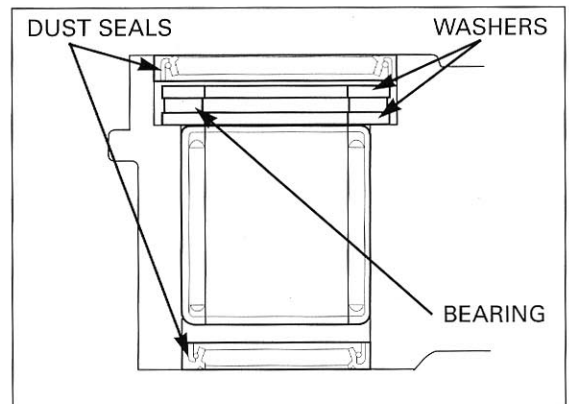

Install the chain slider so its hole fits over the tab on the swingarm.

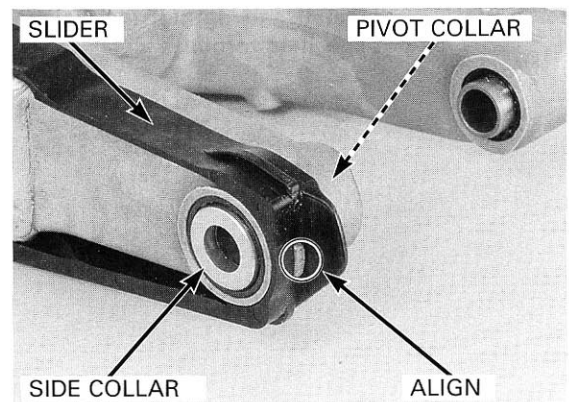

## REAR WHEEL/SUSPENSION

Clean and apply a locking agent to the screw threads.  
Install and tighten the screws to the specified torque.

**TORQUE: 4 N·m (0.4 kgf·m, 2.9 lbf·ft)**

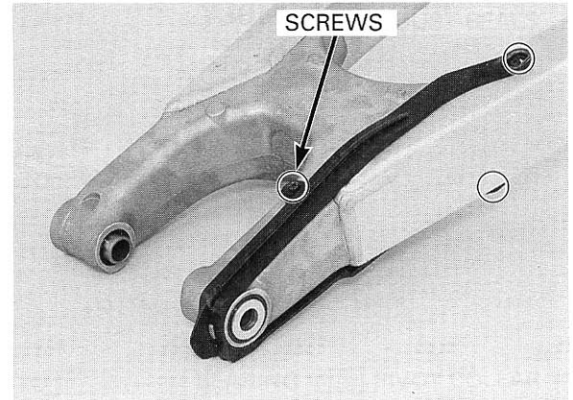

Install the chain guide.  
Install and tighten the bolts and nuts to the specified torque.

**TORQUE: 12 N·m (1.2 kgf·m, 9 lbf·ft)**

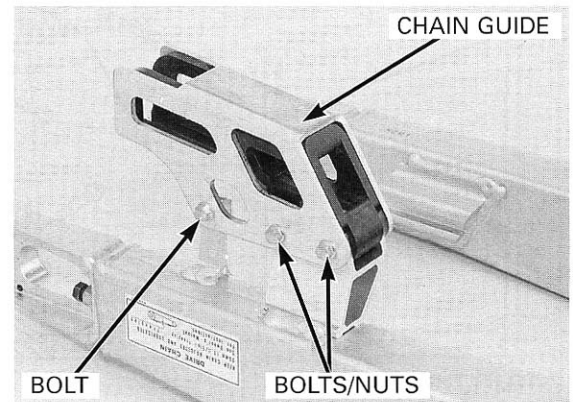

## INSTALLATION

Apply a thin coat of grease to the swingarm pivot bolt sliding surface.  
Install the swingarm onto the frame.  
Install the swingarm pivot bolt to the frame and swingarm pivot.

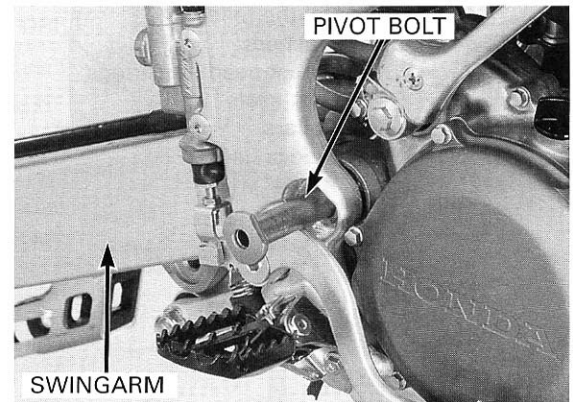

Install and tighten the swingarm pivot nut to the specified torque.

**TORQUE: 88 N·m (9.0 kgf·m, 65 lbf·ft)**

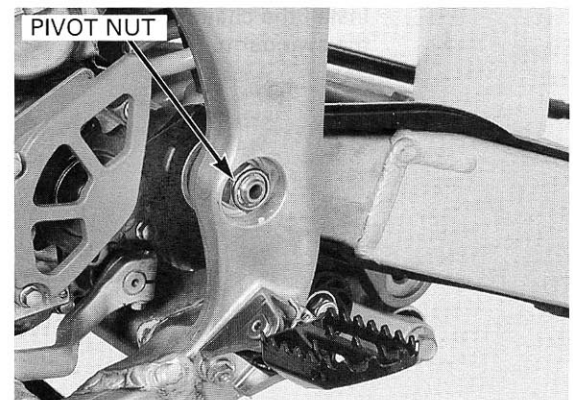

## REAR WHEEL/SUSPENSION

*Do not twist the  
brake hose.*

Install the rear brake caliper to the slide rail on the swingarm.

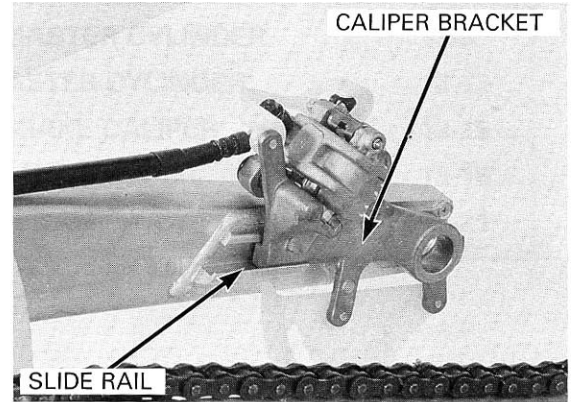

Install the rear brake hose guide and tighten the screw to the specified torque.

**TORQUE: 1.2 N•m (0.12 kgf•m, 0.9 lbf•ft)**

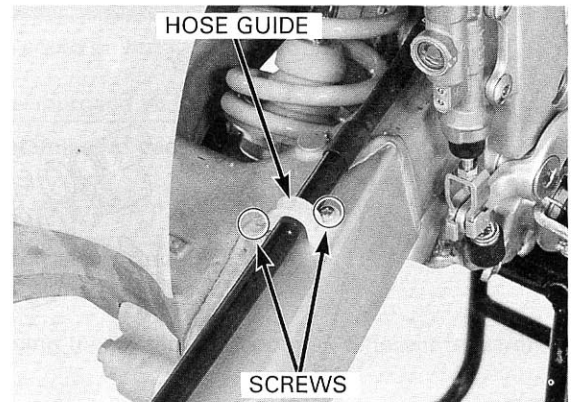

Apply oil to the shock arm nut (swingarm side) threads and seating surface.  
Install the shock arm bolt and nut.  
Tighten the nut to the specified torque.

**TORQUE: 79 N•m (8.1 kgf•m, 59 lbf•ft)**

Install the rear wheel (page 12-8).

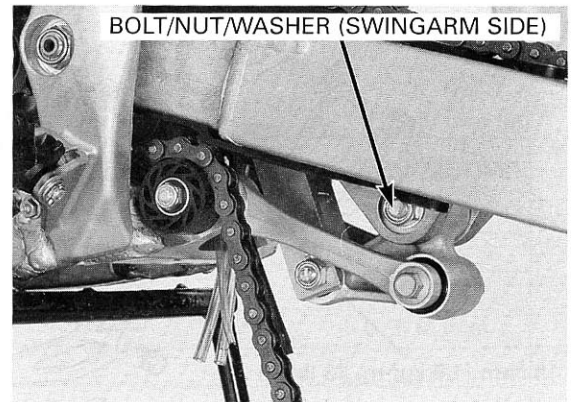

**HYDRAULIC BRAKE**

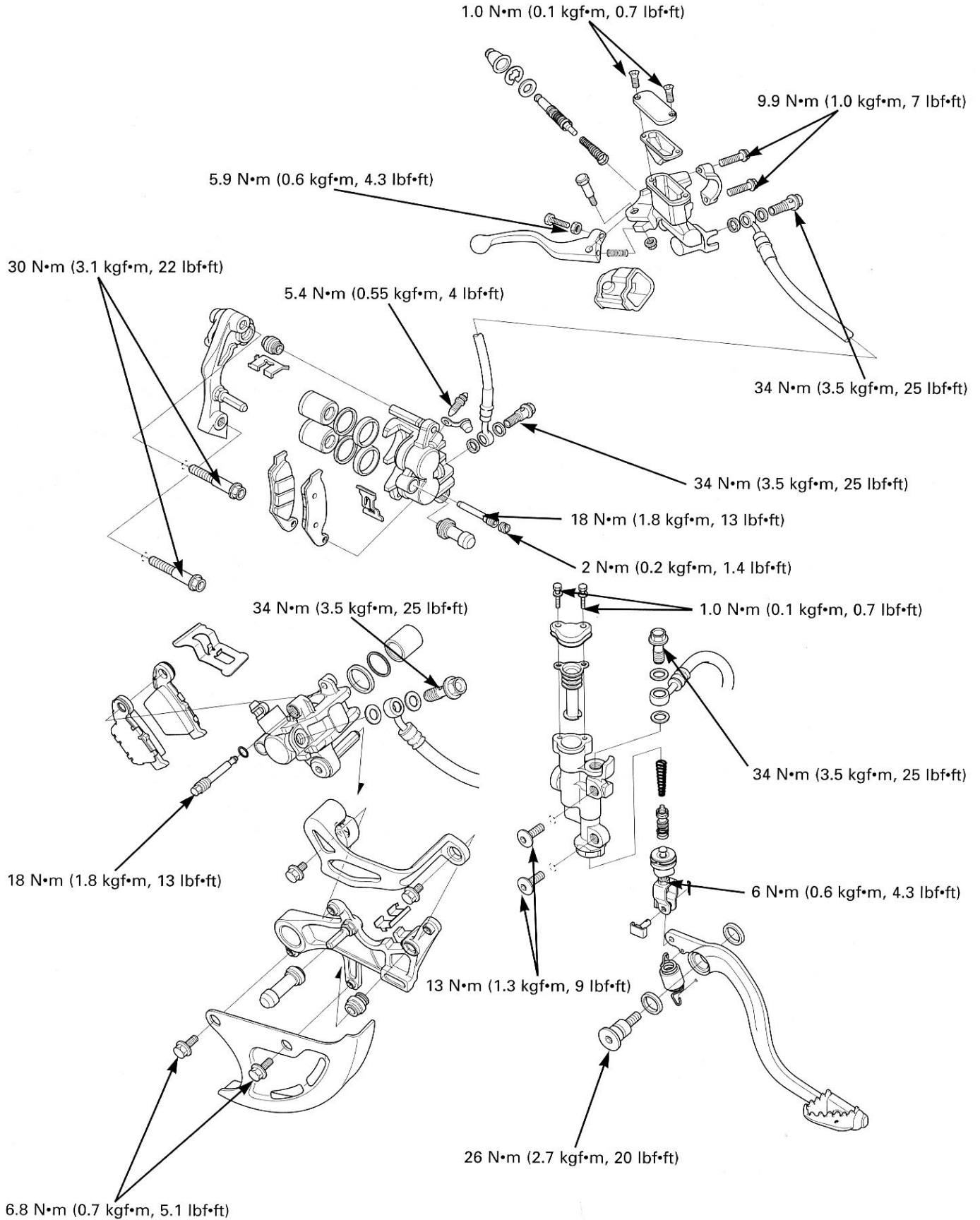

# 13. HYDRAULIC BRAKE

SERVICE INFORMATION	13-1	FRONT MASTER CYLINDER	13-9
TROUBLESHOOTING	13-2	REAR MASTER CYLINDER	13-12
BRAKE FLUID REPLACEMENT/ AIR BLEEDING	13-3	FRONT BRAKE CALIPER	13-15
BRAKE PAD/DISC	13-6	REAR BRAKE CALIPER	13-18
		BRAKE PEDAL	13-21

## SERVICE INFORMATION

### GENERAL

#### ⚠ CAUTION

- Frequent inhalation of brake pad dust, regardless of material composition could be hazardous to your health.
- Avoid breathing dust particles.
  - Never use an air hose or brush to clean brake assemblies. Use an OSHA-approved vacuum cleaner.
  - A contaminated brake disc or pad reduces stopping power. Discard contaminated pads and clean a contaminated disc with high quality brake degreasing agent.
  - Avoid spilling brake fluid on painted, plastic or rubber parts. Place a rag or shop towel over these parts whenever the system is serviced.
  - Be careful whenever you remove the reservoir cap; make sure the reservoir is horizontal.
  - Bleed the hydraulic system if it has been disassembled or if the brake feels spongy.
  - Never allow contaminants (dirt, water, etc.) to get into an open reservoir.
  - Always use fresh DOT 4 brake fluid from a sealed container when servicing the system. Do not mix different types of fluid since they may not be compatible.
  - Always check brake operation before riding the motorcycle.
  - Brake dust may contain asbestos fibers.
  - Never use an air hose or dry brush to clean brake assemblies.
  - Keep grease off of brake pads and disc.

**13**

### SPECIFICATIONS

Unit: mm (in)

	ITEM	STANDARD	SERVICE LIMIT
Front	Specified brake fluid	DOT 4	—
	Brake pad wear indicator	—	1.0 (0.04)
	Brake disc thickness	3.0 (0.12)	2.5 (0.10)
	Brake disc runout	—	0.15 (0.006)
	Master cylinder I.D.	11.00 (0.433)	—
	Caliper cylinder I.D.	27.00 (1.063)	—
Rear	Specified brake fluid	DOT 4	—
	Brake pad wear indicator	—	1.0 (0.04)
	Brake disc thickness	4.0 (0.16)	3.5 (0.14)
	Brake disc runout	—	0.15 (0.006)
	Master cylinder I.D.	9.52 (0.375)	—
	Caliper cylinder I.D.	22.65 (0.892)	—

## HYDRAULIC BRAKE

---

### TORQUE VALUES

Brake hose oil bolt	34 N•m (3.5 kgf•m, 25 lbf•ft)
Brake lever adjuster lock nut	5.9 N•m (0.6 kgf•m, 4.3 lbf•ft)
Front brake hose guide bolt	5.2 N•m (0.53 kgf•m, 3.8 lbf•ft)
Front master cylinder reservoir cover screw	1.0 N•m (0.1 kgf•m, 0.7 lbf•ft)
Front master cylinder holder bolt	9.9 N•m (1.0 kgf•m, 7 lbf•ft)
Front caliper mounting bolt	30 N•m (3.1 kgf•m, 22 lbf•ft) Apply a locking agent.
Brake caliper bleed valve	5.4 N•m (0.55 kgf•m, 4 lbf•ft)
Rear brake disc cover bolt	6.8 N•m (0.7 kgf•m, 5.1 lbf•ft)
Rear master cylinder reservoir cover bolt	1.0 N•m (0.1 kgf•m, 0.7 lbf•ft)
Rear master cylinder mounting bolt	13 N•m (1.3 kgf•m, 9 lbf•ft)
Front brake caliper pin bolt	22 N•m (2.2 kgf•m, 16 lbf•ft) Apply a locking agent.
Rear brake caliper pin bolt	27 N•m (2.8 kgf•m, 20 lbf•ft) Apply a locking agent.
Brake caliper pad pin	18 N•m (1.8 kgf•m, 13 lbf•ft)
Brake caliper pad pin plug	2 N•m (0.2 kgf•m, 1.4 lbf•ft)
Rear brake caliper bracket pin bolt	12 N•m (1.2 kgf•m, 9 lbf•ft) Apply a locking agent.
Brake pedal pivot bolt	26 N•m (2.7 kgf•m, 20 lbf•ft)
Rear master cylinder joint nut	6 N•m (0.6 kgf•m, 4.3 lbf•ft)

### TOOL

Snap ring pliers	07914-SA50001
------------------	---------------

### TROUBLESHOOTING

#### Brake lever/pedal soft or spongy

- Air in hydraulic system
- Leaking hydraulic system
- Contaminated brake pads/disc
- Worn caliper piston seal
- Worn master cylinder piston cups
- Worn brake pads/disc
- Contaminated caliper
- Caliper not sliding properly
- Low brake fluid level
- Clogged fluid passage
- Warped/deformed brake disc
- Sticking/worn caliper piston
- Sticking/worn master cylinder piston
- Contaminated master cylinder
- Bent brake lever/pedal

#### Brake lever/pedal hard

- Clogged/restricted brake system
- Sticking/worn caliper piston
- Caliper not sliding properly
- Clogged/restricted fluid passage
- Worn caliper piston seal
- Sticking/worn master cylinder piston
- Bent brake lever/pedal

#### Brake drags

- Contaminated brake pads/disc
- Misaligned wheel
- Clogged/restricted brake hose joint
- Warped/deformed brake disc
- Caliper not sliding properly
- Clogged/restricted brake hydraulic system
- Sticking/worn caliper piston
- Clogged master cylinder port

## BRAKE FLUID REPLACEMENT/AIR BLEEDING

*A contaminated brake disc or pad reduces stopping power. Discard contaminated pads and clean a contaminated disc with a high quality brake degreasing agent.*

*Do not allow foreign material to enter the system when filling the reservoir. Avoid spilling brake fluid on plastic or rubber parts. Place a rag over these parts whenever the system is serviced.*

- Once the hydraulic system has been opened, or if the brake feels spongy, the system must be bled.
- When using a commercially available brake bleeder, follow the manufacturer's operating instructions.

### BRAKE FLUID DRAINING

Check the master cylinder parallel to the ground, before removing the reservoir cover and cap.

Remove the screws, reservoir cover and diaphragm.

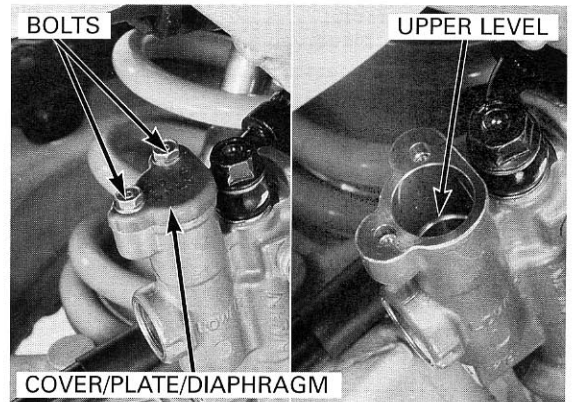
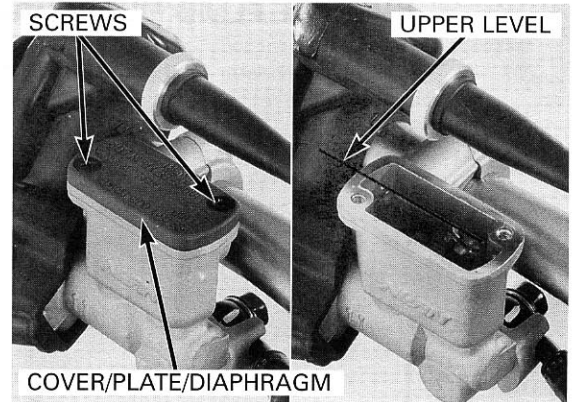
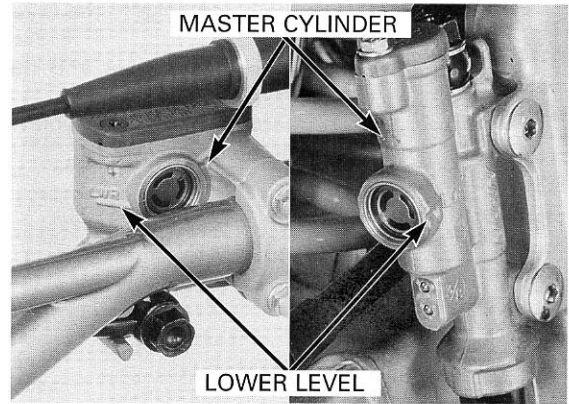

*Rear caliper only:* Remove the bolts and brake caliper guard.

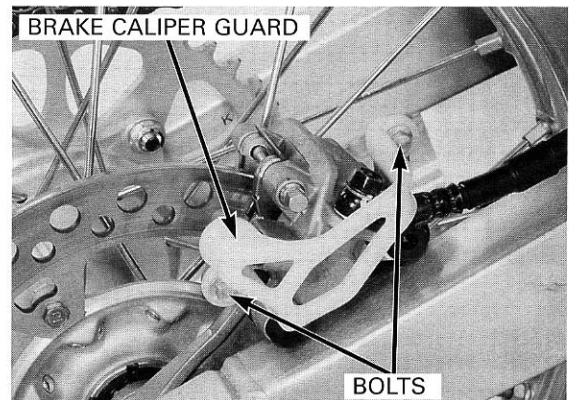



## HYDRAULIC BRAKE

Connect a bleed hose to the bleed valve.

Loosen the bleed valve and pump the brake lever (pedal).

Stop operating the brake when no more fluid flows out of the bleed valve.

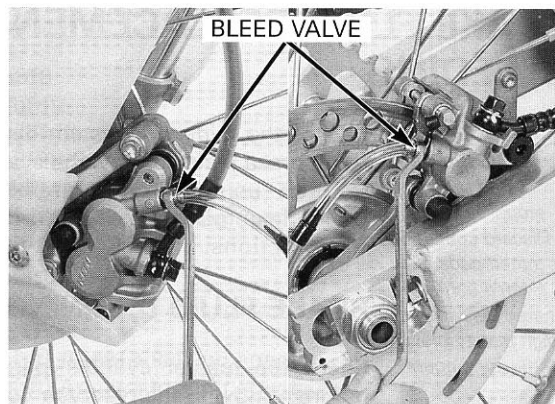

### BRAKE FLUID FILLING/AIR BLEEDING

*Do not mix different types of fluid since they are not compatible.*

Fill the master cylinder with DOT 4 brake fluid to the upper level.

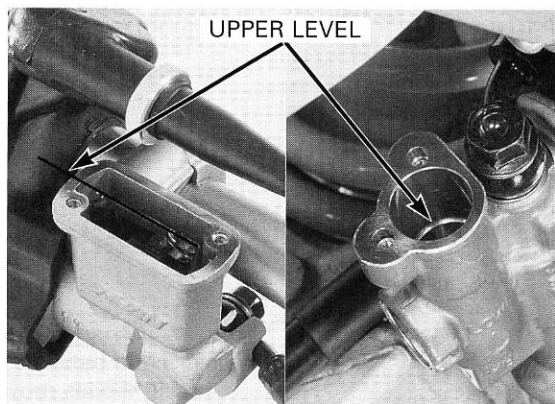

Connect a commercially available brake bleeder to the bleed valve.

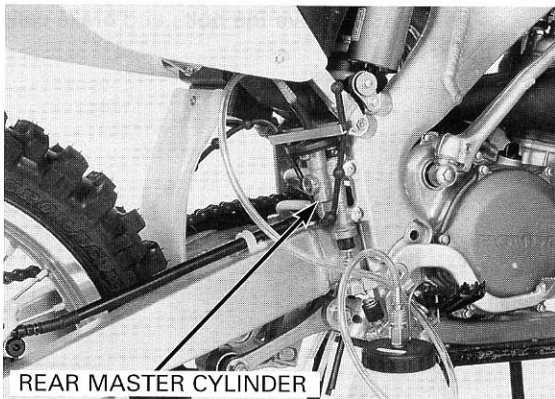
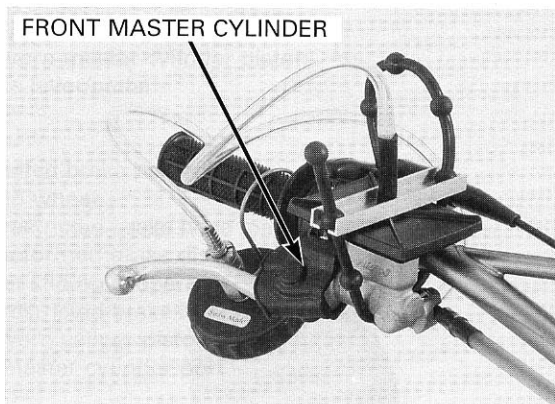

*If air enters the bleeder from around the bleed valve threads, seal the threads with teflon tape.*

Operate the brake bleeder and loosen the bleed valve. If an automatic refill system is not used, add fluid when the fluid level in the reservoir is low. Perform the bleeding procedure until the system is completely flushed/bled.

Close the bleed valve and operate the brake lever. If it still feels spongy, bleed the system again.

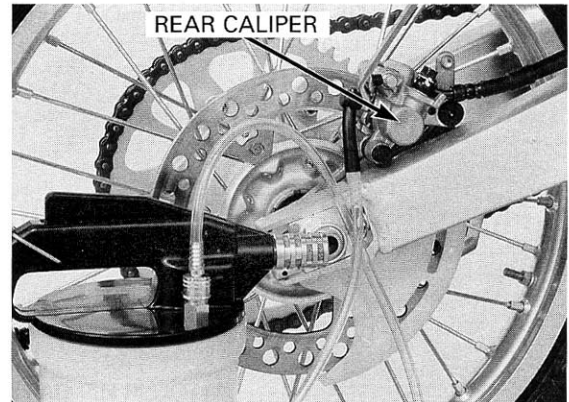
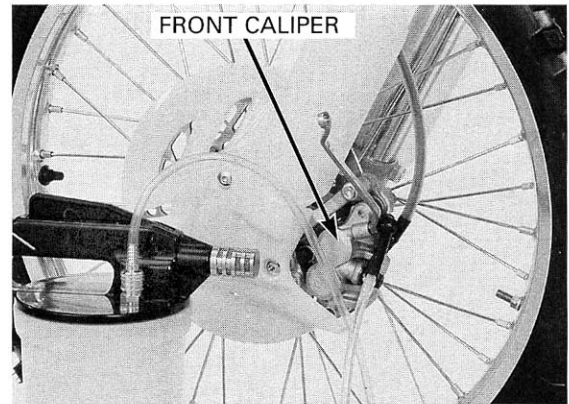

If a brake bleeder is not available, perform the following procedure.

Pressurize the system with the lever until there are no air bubbles in the fluid flowing out of the reservoir small hole and lever resistance is felt.

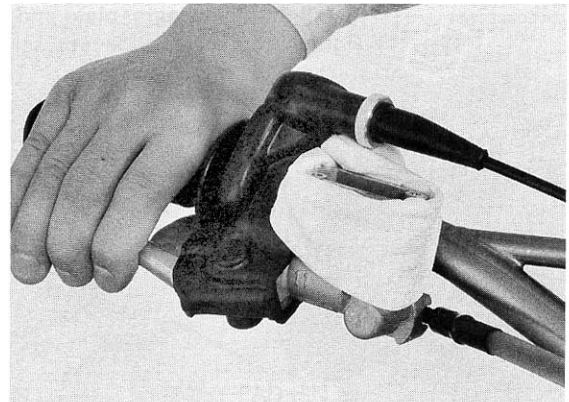

*Do not release the brake lever or pedal until the bleed valve has been closed.*

1. Pump the brake lever or pedal several times, then squeeze the brake lever or pedal all the way and loosen the bleed valve 1/2 of a turn. Wait several seconds and close the bleed valve.
2. Release the brake lever or pedal slowly until the bleed valve has been closed.
3. Repeat steps 1 – 2 until there are no air bubbles in the bleed hose.

After bleeding air completely, tighten the bleed valves to the specified torque.

**TORQUE: 5.4 N·m (0.55 kgf·m, 4 lbf·ft)**

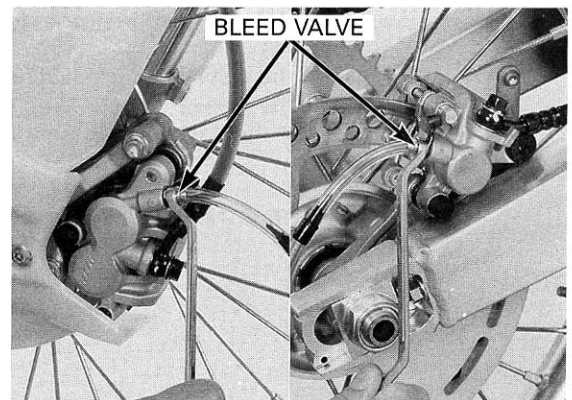

## HYDRAULIC BRAKE

Install the brake caliper guard and tighten the bolts securely.

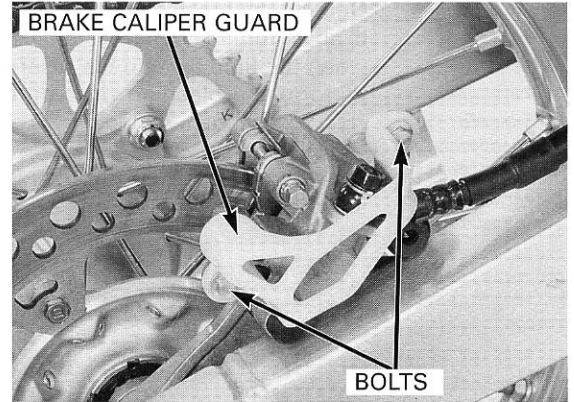

Fill the reservoir with DOT 4 brake fluid to the upper level.

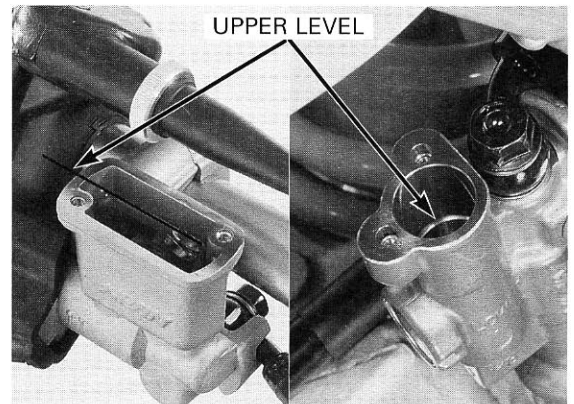

Install the diaphragm, plate and reservoir cover. Tighten the reservoir cover screws to the specified torque.

**TORQUE: 1.0 N·m (0.1 kgf·m, 0.7 lbf·ft)**

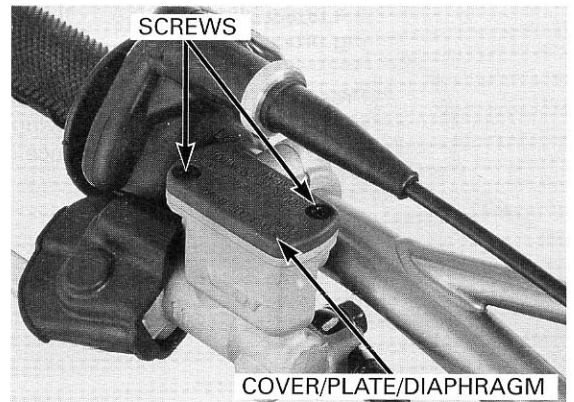

Straighten the diaphragm and install it to the rear master cylinder. Check the diaphragm installation as shown. Install the plate and reservoir cover. Tighten the reservoir cover bolts to the specified torque.

**TORQUE: 1.0 N·m (0.1 kgf·m, 0.7 lbf·ft)**

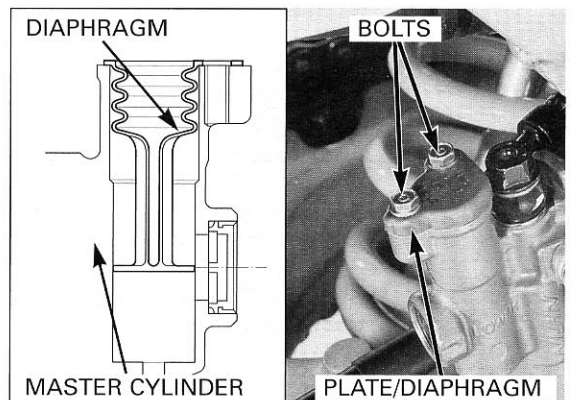

## BRAKE PAD/DISC

### BRAKE PAD REPLACEMENT

Remove the brake disc cover (page 11-4).

*Always replace the brake pads in pairs to assure even disc pressure.*

Push the caliper pistons all the way in to allow installation of new brake pads.

Check the brake fluid level in the brake master cylinder reservoir as this operation causes the level to rise.

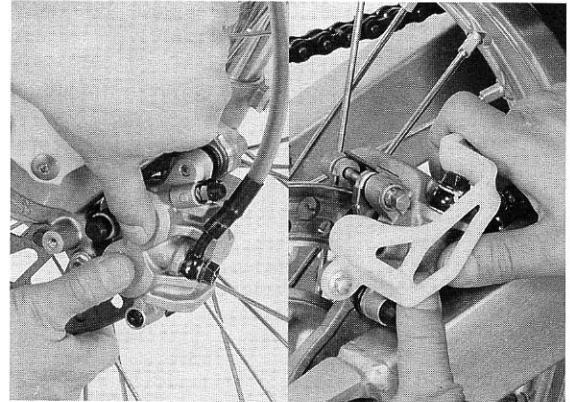

*Front caliper only:* Remove the pad pin plug and loosen the pad pin.

*Rear caliper only:* Loosen the pad pin.

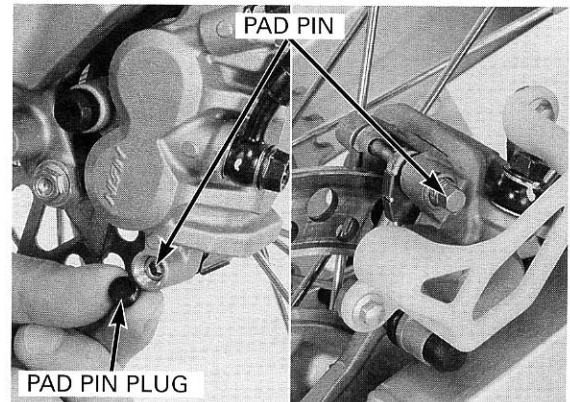

Remove the pad pin and brake pads.

*Rear caliper only:* Remove the ring from the pad pin and replace it with a new one.

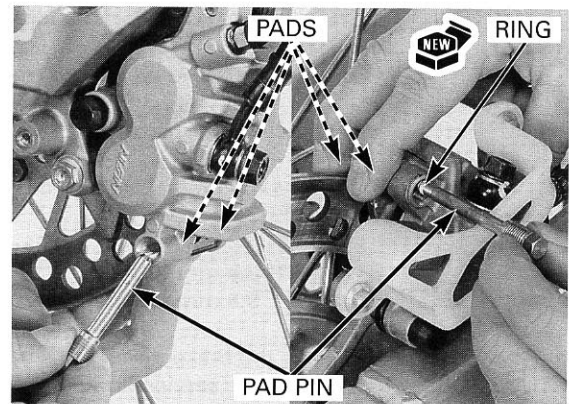

Install the new brake pads to the pad retainer securely.

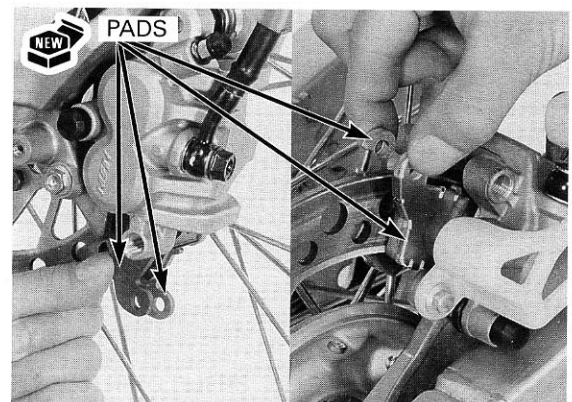

## HYDRAULIC BRAKE

Push the brake pads against the pad spring, then install the pad pin.

Tighten the pad pin to the specified torque.

**TORQUE: 18 N·m (1.8 kgf·m, 13 lbf·ft)**

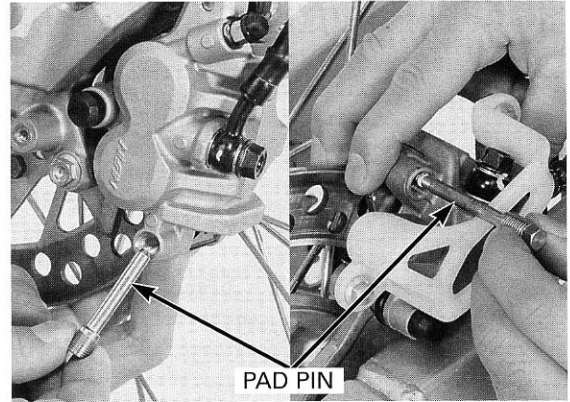

*Front caliper only:* Install and tighten the pad pin plug.

**TORQUE: 2 N·m (0.2 kgf·m, 1.4 lbf·ft)**

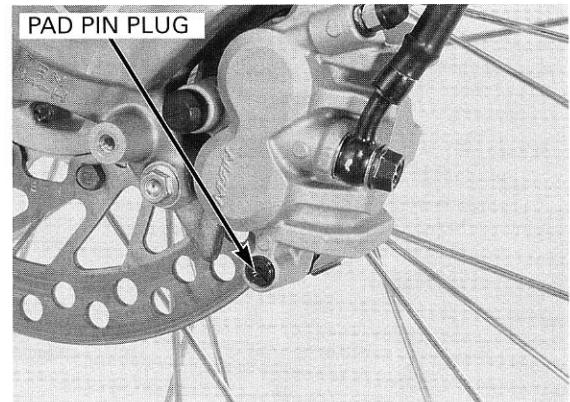

## BRAKE DISC INSPECTION

Remove the brake disc cover (page 11–4).

Visually inspect the brake disc for damage or cracks.

Measure the brake disc thickness with a micrometer.

### SERVICE LIMITS:

**FRONT: 2.5 mm (0.10 in)**

**REAR: 3.5 mm (0.16 in)**

Replace the brake disc if the smallest measurement is less than the service limit.

Measure the brake disc warpage with a dial indicator.

**SERVICE LIMIT: 0.15 mm (0.006 in)**

Check the wheel bearings for excessive play, if the warpage exceeds the service limit.

Replace the brake disc if the wheel bearings are normal.

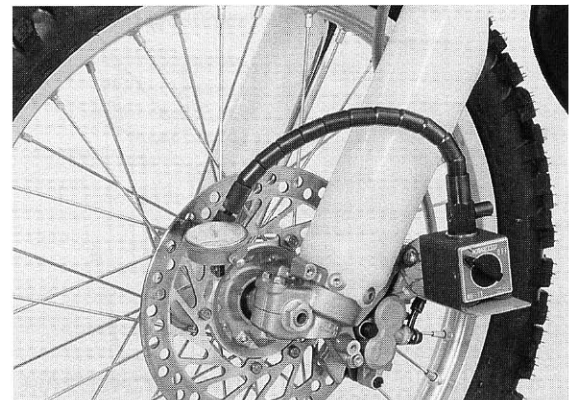

## FRONT MASTER CYLINDER

### REMOVAL

Drain the front brake hydraulic system (page 13-3).

*When removing the brake hose bolt, cover the end of the hose to prevent contamination. Secure the hose to prevent fluid from leaking out.*

Remove the brake hose oil bolt, sealing washers and brake hose eyelet.

Remove the bolts from the master cylinder holder and remove the master cylinder assembly.

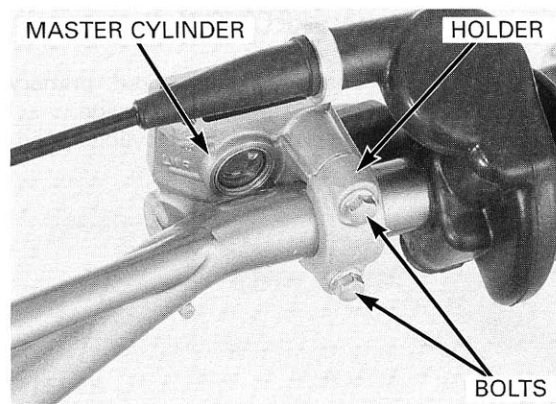
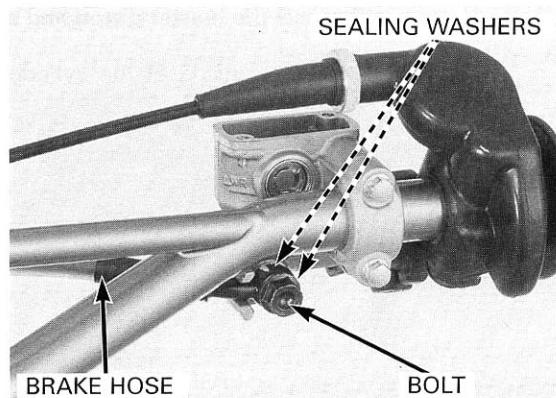

### DISASSEMBLY

Remove the dust cover.  
Remove the pivot bolt/nut and brake lever assembly.

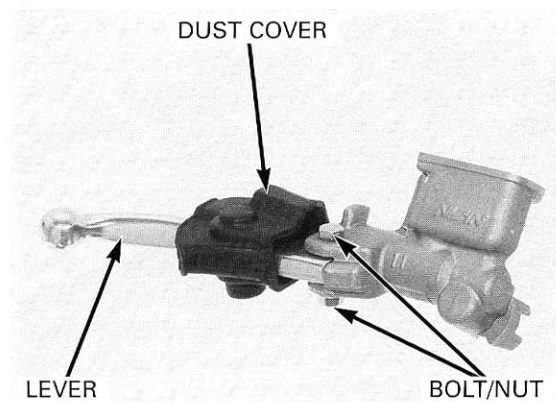

Remove the boot.

Remove the snap ring from the master cylinder body using the special tool as shown.

**TOOL:**  
Snap ring pliers

07914-SA50001

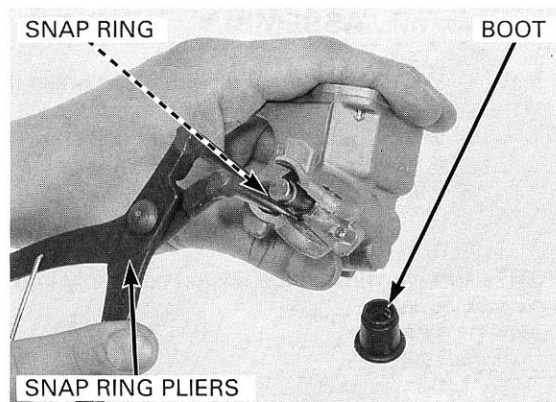

## HYDRAULIC BRAKE

Remove the master piston and spring.

Clean the inside of the cylinder and reservoir with brake fluid.

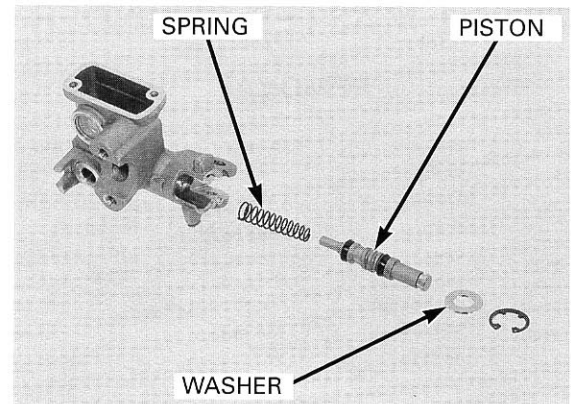

### INSPECTION

Check the piston boot, primary cup and secondary cup for fatigue or damage.  
Check the master cylinder and piston for abnormal scratches.

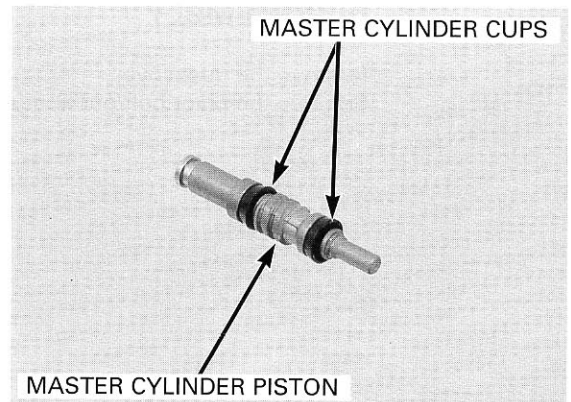
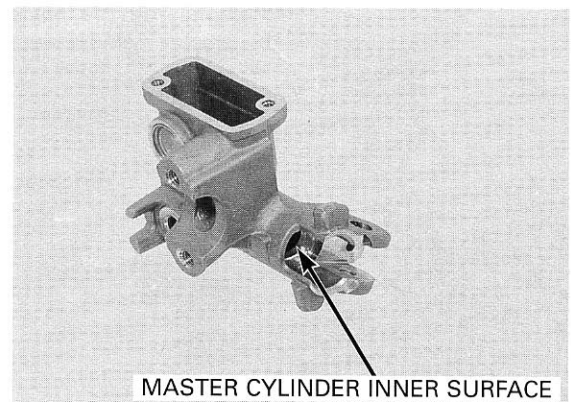

### ASSEMBLY

*Replace the piston, cups, spring, snap ring and boot as a set; do not substitute individual parts.*

Coat all parts with clean brake fluid before assembly.  
Dip the piston in brake fluid.  
Install the spring to the piston.

*When installing the cups, do not allow the lips to turn inside out.*

Install the piston assembly into the master cylinder.

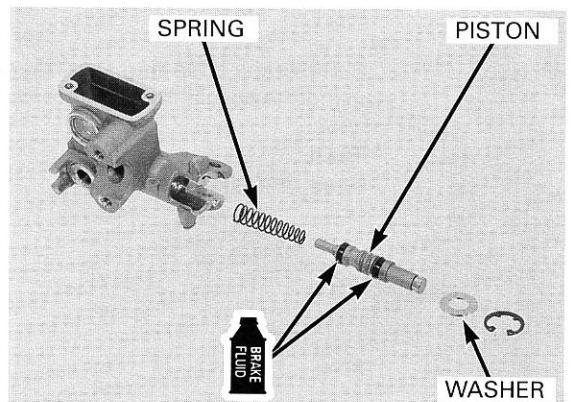

*Be certain the snap ring is firmly seated in the groove.*

Install the snap ring using the special tool.

**TOOL:**  
**Snap ring pliers** **07914-SA50001**

Apply silicone grease to the inside of the boot.  
 Install the boot.

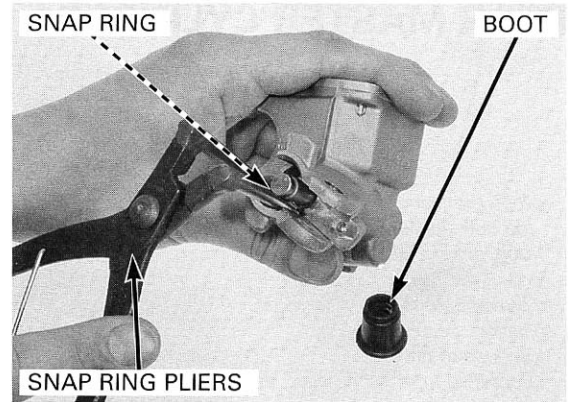

Install the brake lever.  
 Install and tighten the pivot bolt to the specified torque.

**TORQUE: 5.9 N•m (0.6 kgf•m, 4.3 lbf•ft)**

Hold the pivot nut to the specified torque.

**TORQUE: 5.9 N•m (0.6 kgf•m, 4.3 lbf•ft)**

Install the dust cover.

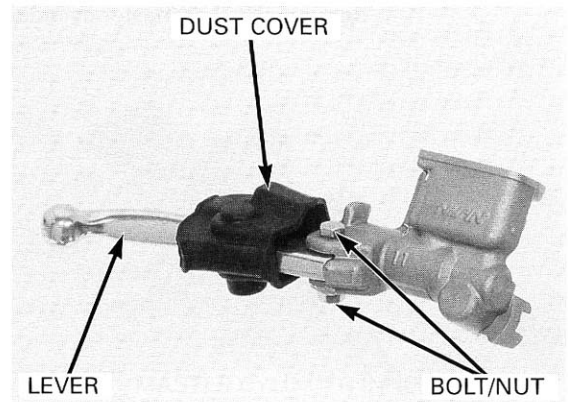

**INSTALLATION**

Place the master cylinder assembly on the handlebar.  
 Align the end of the master cylinder with the punch mark on the handlebar.

Install the master cylinder holder with the "UP" mark facing up.  
 Tighten the upper bolt first, then the lower bolt.

**TORQUE: 9.9 N•m (1.0 kgf•m, 7 lbf•ft)**

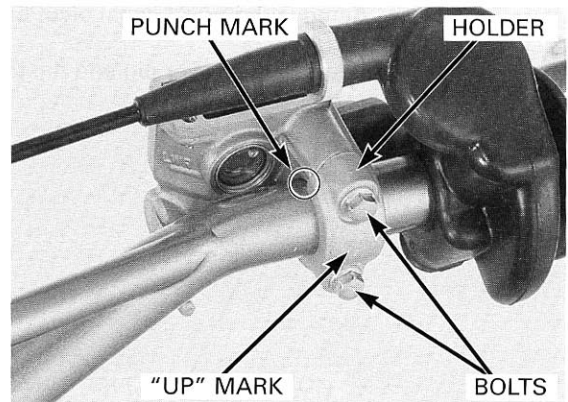

Align the brake hose eyelet between the stoppers.  
 Install the brake hose eyelet with the oil bolt and new sealing washers.  
 Tighten the oil bolt to the specified torque.

**TORQUE: 34 N•m (3.5 kgf•m, 25 lbf•ft)**

Fill the reservoir to the upper level and bleed the front brake system (page 13-4).

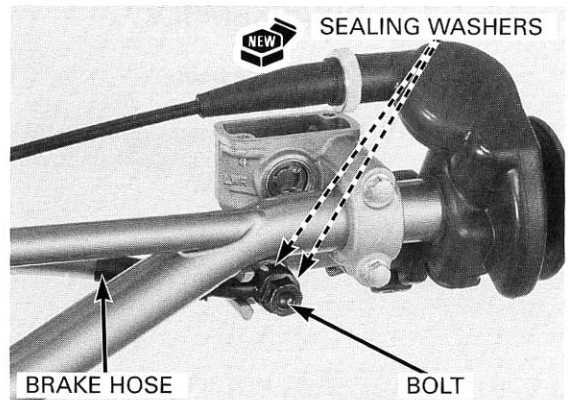



## HYDRAULIC BRAKE

### REAR MASTER CYLINDER

#### REMOVAL

Drain the rear brake hydraulic system (page 13-3).

*When removing the brake hose bolt, cover the end of the hose to prevent contamination. Secure the hose to prevent fluid from leaking out.*

Remove the brake hose oil bolt, sealing washers and brake hose.

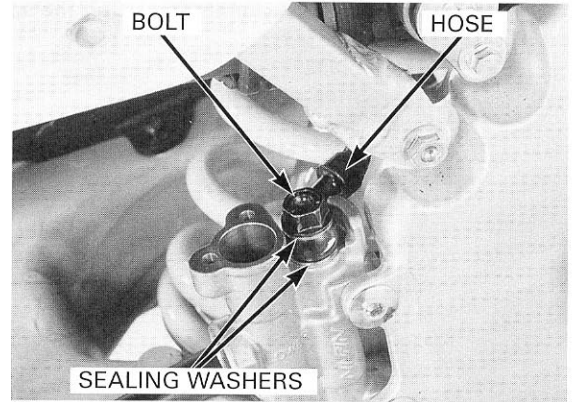

Remove the rear master cylinder mounting bolts.

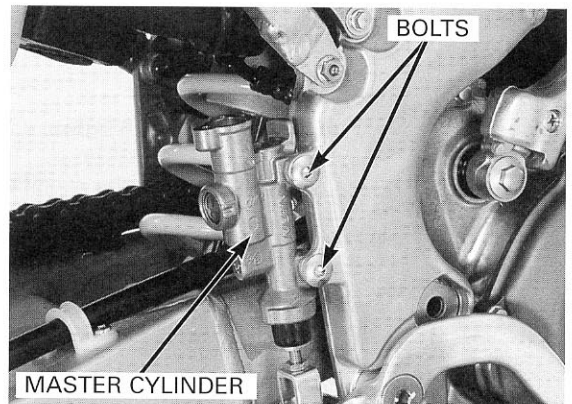

Remove the brake pedal pivot bolt (page 13-21).

Remove the cotter pin and the joint pin.

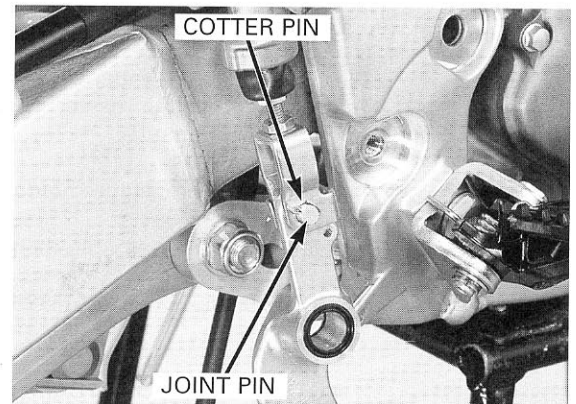

#### DISASSEMBLY

Remove the boot.

Remove the snap ring from the master cylinder body using the special tool as shown.

#### TOOL:

Snap ring pliers

07914-SA50001

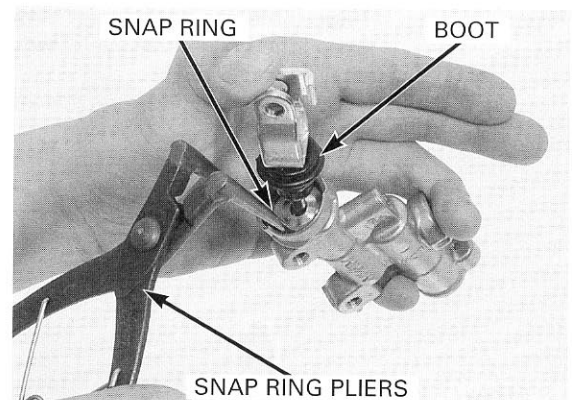

Remove the push rod, master piston and spring.

Clean the inside of the cylinder with brake fluid.

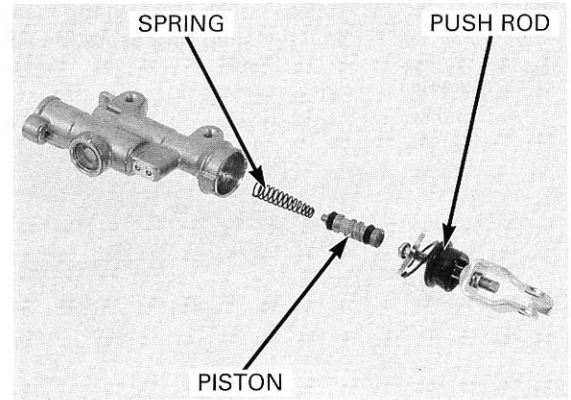

## INSPECTION

Check the piston boot, primary cup and secondary cup for fatigue or damage. Check the master cylinder and piston for abnormal scratches.

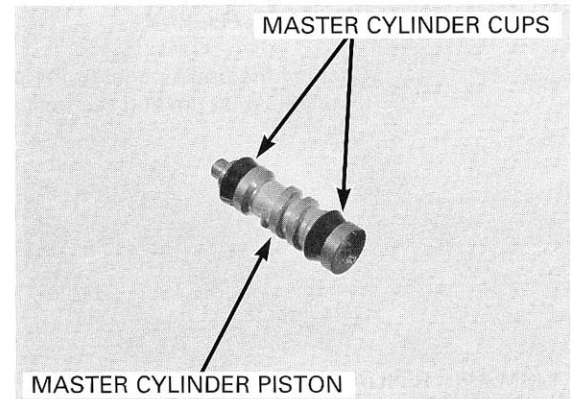
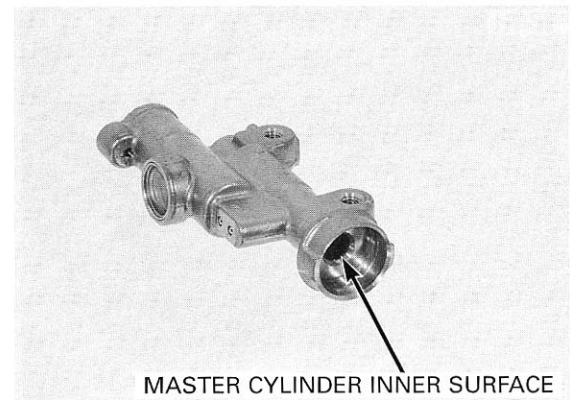

## ASSEMBLY

*Keep the piston, cups, spring, snap ring and boot as a set; do not substitute individual parts.*

Coat all parts with clean brake fluid before assembly. Dip the piston in brake fluid. Install the spring to the piston.

*When installing the cups, do not allow the lips to turn inside out.*

Install the piston assembly. Apply grease to the piston contact area of the push rod.

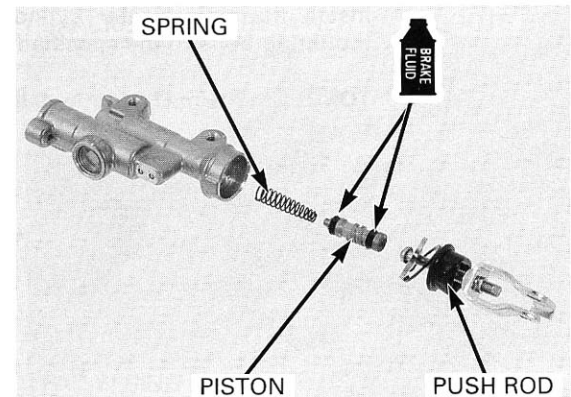

## HYDRAULIC BRAKE

*Be certain the snap ring is firmly seated in the groove.*

Install the push rod into the master cylinder.  
Install the snap ring using the special tool.

**TOOL:**

**Snap ring pliers**

**07914-SA50001**

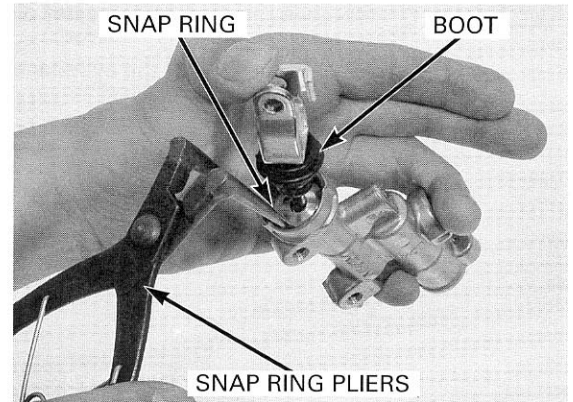

Install the boot.

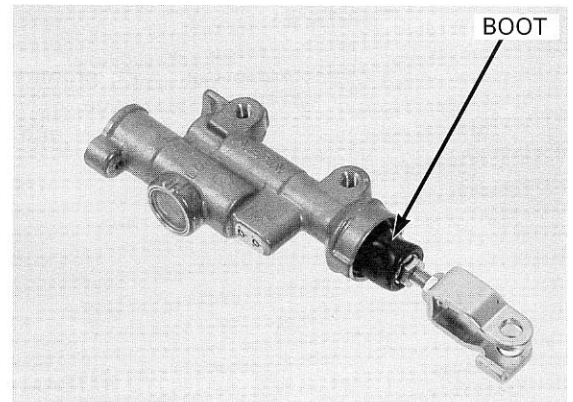

### INSTALLATION

Connect the brake pedal to the push rod lower joint.  
Install the joint pin and secure it with a new cotter pin.

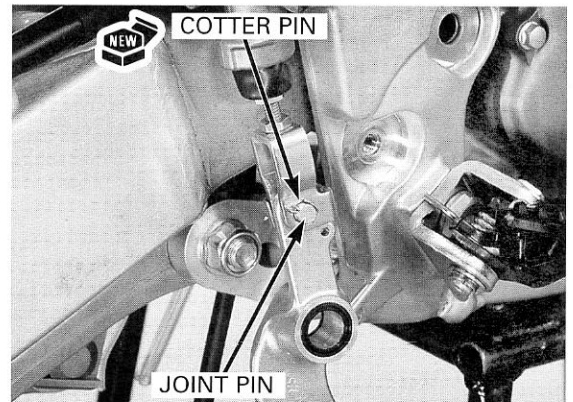

Install the rear master cylinder and tighten the mounting bolts to the specified torque.

**TORQUE: 13 N·m (1.3 kgf·m, 9 lbf·ft)**

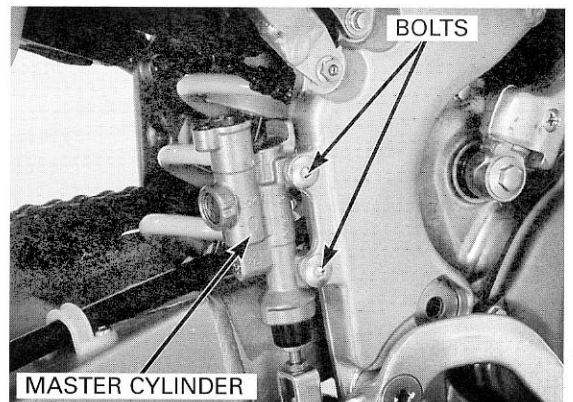

Install the brake hose with the oil bolt and new sealing washers.  
Push the eyelet joint against the stopper, then tighten the oil bolt to the specified torque.

**TORQUE: 34 N·m (3.5 kgf·m, 25 lbf·ft)**

Fill the reservoir to the upper level and bleed the rear brake line (page 13-4).

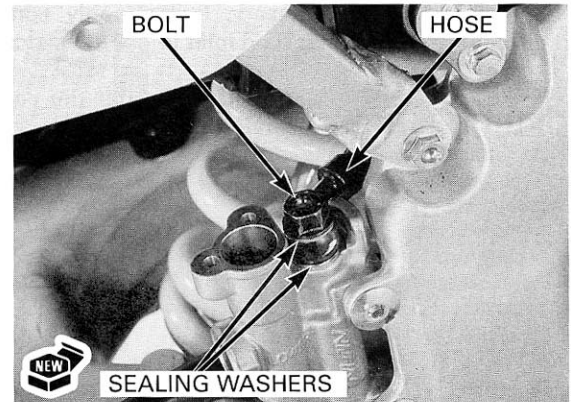

## FRONT BRAKE CALIPER

### REMOVAL

Drain the brake pedal hydraulic system (page 13-3).  
Remove the brake pad (page 13-7).

Remove the oil bolts, sealing washers and brake hose eyelet joints.

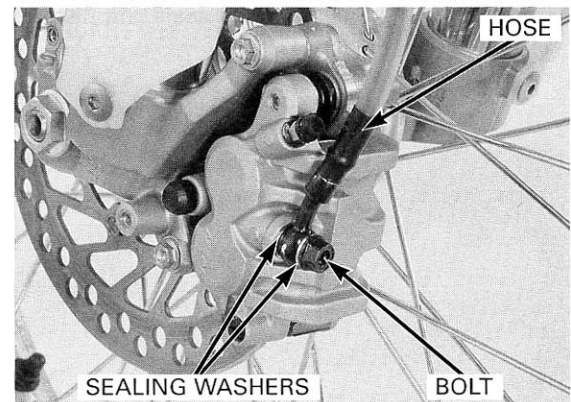

Remove the caliper mounting bolts and then remove the caliper and bracket as an assembly.

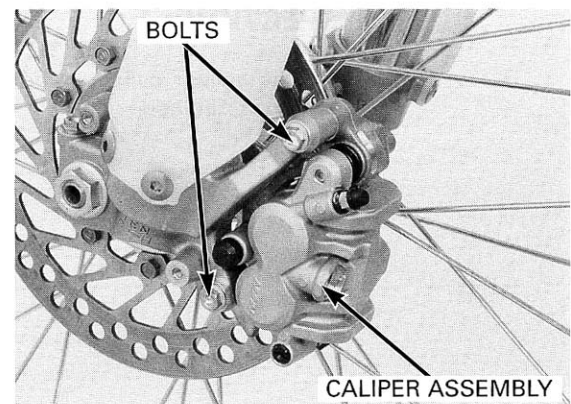

### DISASSEMBLY

Remove the caliper bracket from the caliper body.

Remove the brake pad spring from the caliper body.  
Remove the brake pad retainer from the caliper bracket.  
Remove the caliper pin and bracket pin boots.

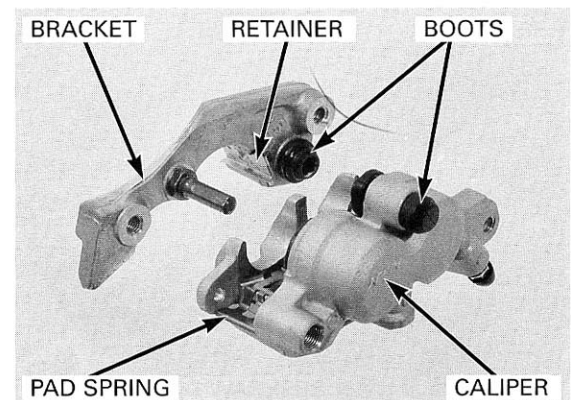

## HYDRAULIC BRAKE

If necessary, lightly apply compressed air to the caliper fluid inlet to get the piston out.

Place a shop rag under the caliper to cushion the piston when it is expelled.  
Use the air in short spurts.

*Do not bring the air nozzle too close to the inlet or the pistons may be forced out with excessive force that could cause injury.*

*Be careful not to damage the piston sliding surface.*

Push the dust seals and piston seals in and lift them out.

Clean the seal grooves, caliper pistons and caliper piston sliding surfaces with clean brake fluid.

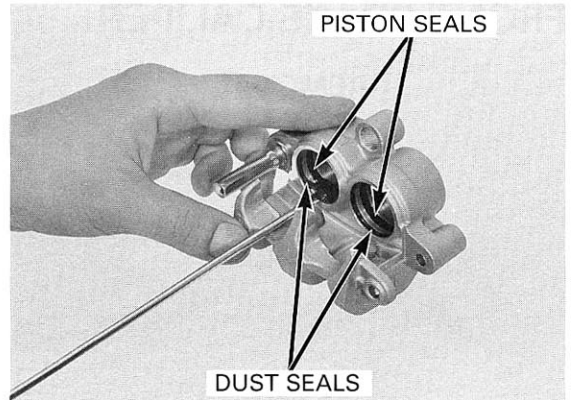
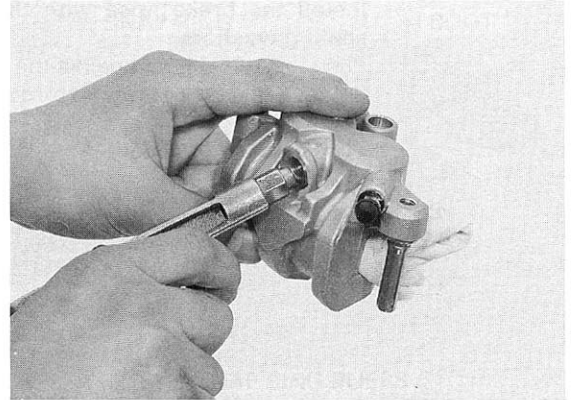

### INSPECTION

Check the caliper cylinder and pistons for scoring, scratches or damage.

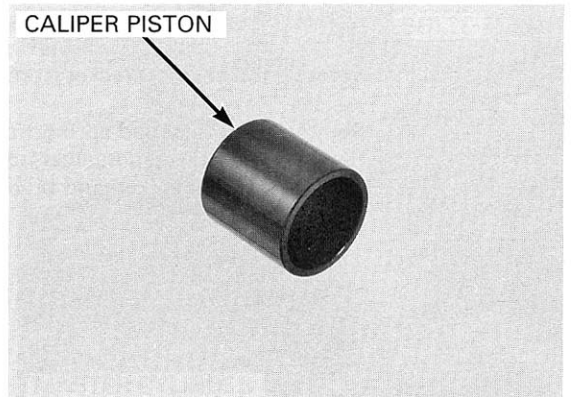
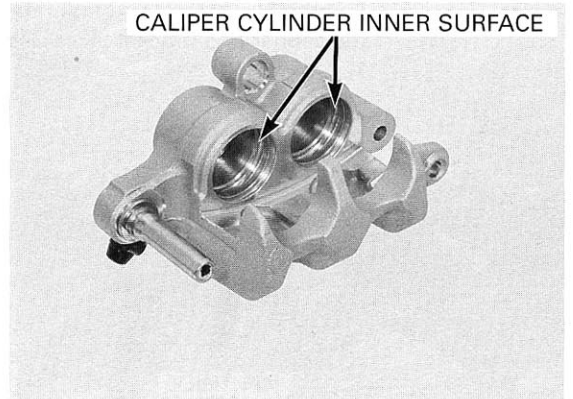

**ASSEMBLY**

- Replace the dust seals and piston seals with new ones.
- Be sure that each part is free from the dust or dirt before reassembly.

Coat the new piston seals with clean brake fluid.  
 Coat the new dust seals with silicone grease.  
 Install the piston and dust seals into the grooves in the caliper body.  
 Coat the caliper pistons with clean brake fluid and install them into the caliper cylinder with their closed ends facing the pad.

*Install each piston seal, dust seal and caliper piston in their proper locations.*

Install the brake pad retainer onto the caliper bracket.  
 Install the pad spring into the caliper body.

*Note the installation direction of the pad spring.*

Replace the caliper and bracket pin boots if there is wear, deterioration or damage.  
 Apply silicone grease to the inside of the boots then install them.

Assemble the caliper and bracket.

*When assembling the caliper and bracket, set the boot into the slide pin groove.*

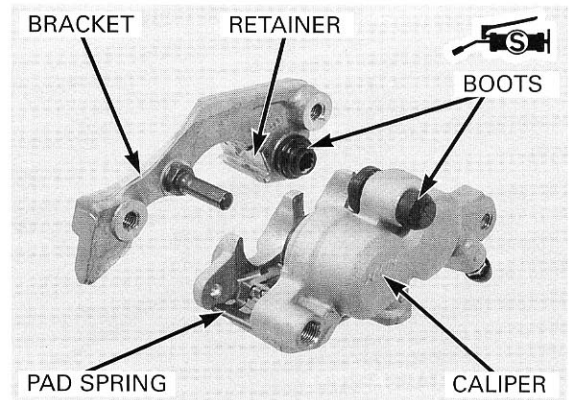
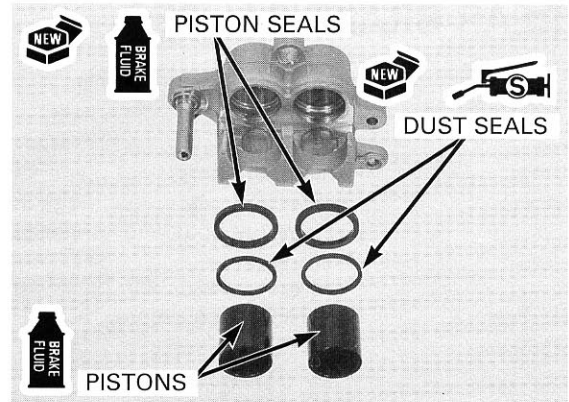

**INSTALLATION**

Install the caliper/bracket assembly to the fork leg.  
 Clean and apply a locking agent to the caliper mounting bolt threads.  
 Install and tighten the mounting bolt to the specified torque.

**TORQUE: 30 N·m (3.1 kgf·m, 22 lbf·ft)**

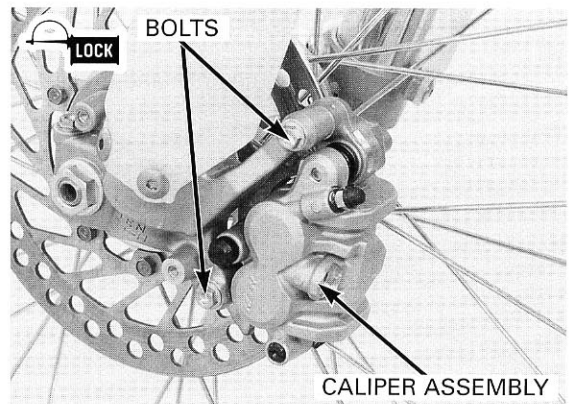

Install the brake hose eyelet to the caliper body with new sealing washers and oil bolts.  
 Push the brake hose eyelet to the stopper on the caliper, then tighten the oil bolts to the specified torque.

**TORQUE: 34 N·m (3.5 kgf·m, 25 lbf·ft)**

Install the brake pad (page 13-7).  
 Fill and bleed the hydraulic system (page 13-4).  
 Install the brake disc cover (page 11-9).

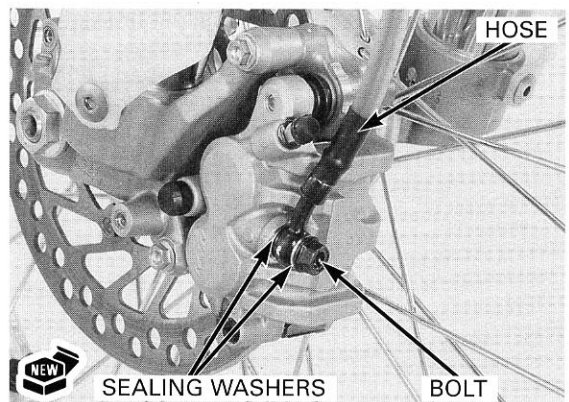

**REAR BRAKE CALIPER**

**REMOVAL**

Drain the pedal brake hydraulic system (page 13-3).  
Remove the brake pad (page 13-7).  
Remove the rear wheel (page 12-4).  
Remove the bolts and caliper guard (page 13-3).

Slide the brake caliper backward and pull it off of the slide rail on the swingarm.

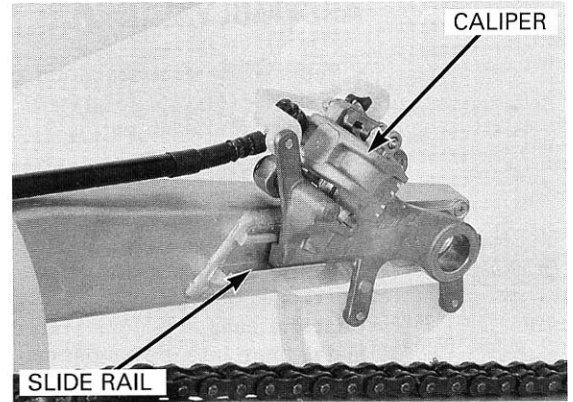

Remove the oil bolts, sealing washers and brake hose eyelet joint.

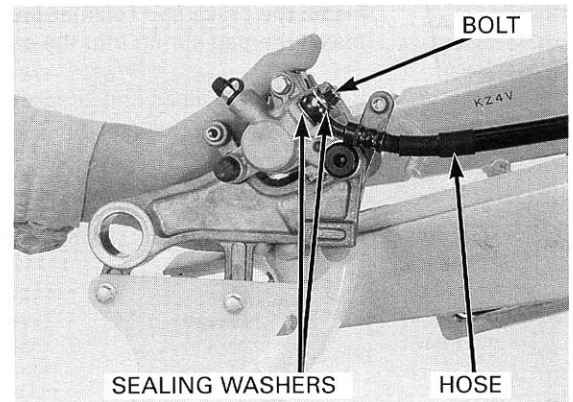

**DISASSEMBLY**

Remove the bolts and brake disc guard.

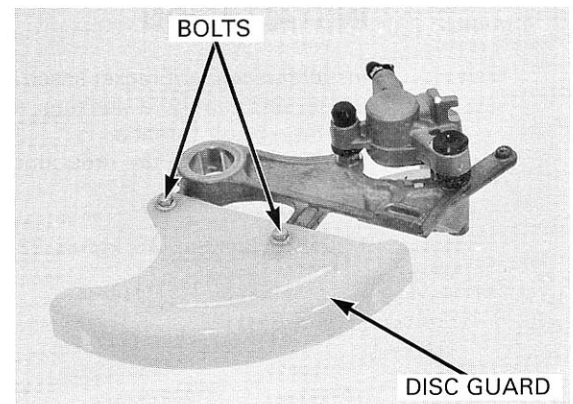

Remove the caliper bracket from the caliper body.

Remove the brake pad spring from the caliper body.  
Remove the brake pad retainer from the caliper bracket.

Remove the caliper pin and bracket pin boots.

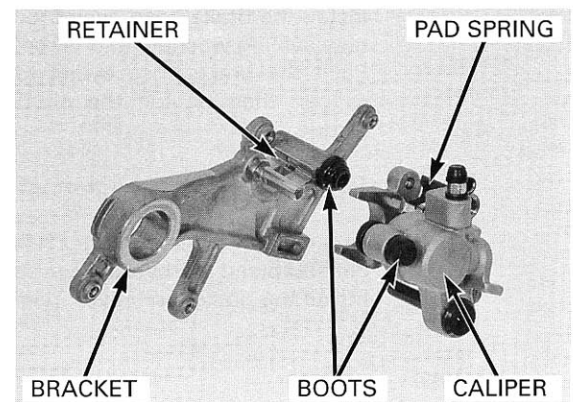

If necessary, lightly apply compressed air to the caliper fluid inlet to get the piston out.

Place a shop rag under the caliper to cushion the piston when it is expelled. Use the air in short spurts.

*Do not bring the air nozzle too close to the inlet or the pistons may be forced out with excessive force that could cause injury.*

*Be careful not to damage the piston sliding surface.*

Push the dust seal and piston seal in and lift them out. Clean the seal grooves, caliper piston and caliper piston sliding surface with clean brake fluid.

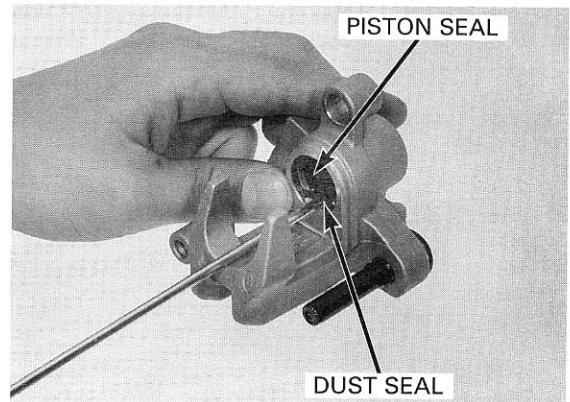
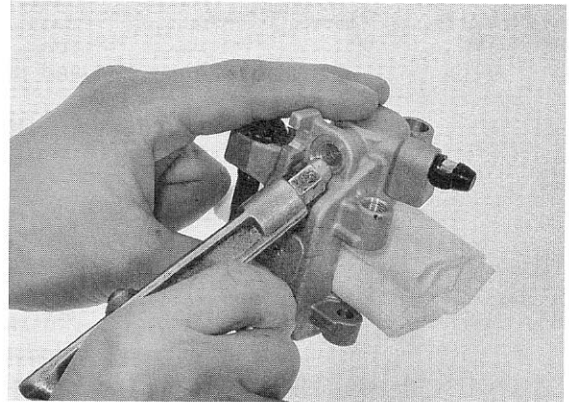

## INSPECTION

Check the caliper cylinder and pistons for scoring, scratches or damage.

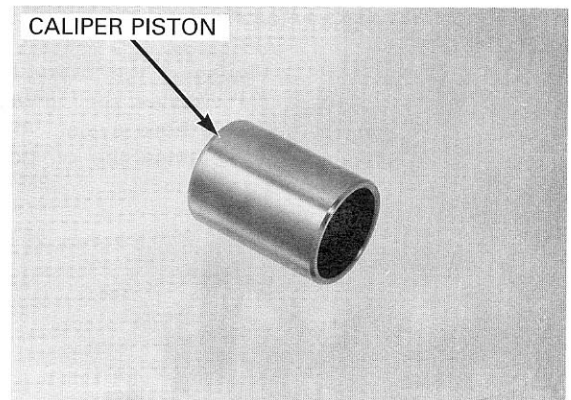
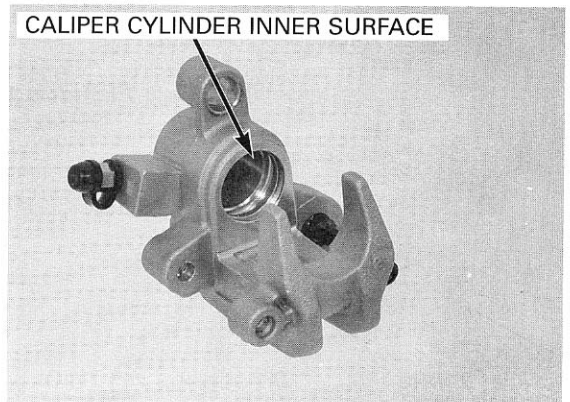



# HYDRAULIC BRAKE

## ASSEMBLY

- Replace the dust seal and piston seal with new ones.
- Be sure each part is free from dust or dirt before reassembly.

Coat the new piston seal with clean brake fluid.  
Coat the new dust seal with silicone grease.  
Install the piston and dust seals into the groove of the caliper body.  
Coat the caliper piston with clean brake fluid and install it into the pad caliper cylinder with its closed end facing the pad.

*Install the piston seal, dust seal and caliper piston in their proper locations.*

*Note the installation direction of the pad spring.*

Install the brake pad retainer onto the caliper bracket.  
Install the pad spring into the caliper body.

Replace the caliper and bracket pin boots if there is wear, deterioration or damage.  
Apply silicone grease to the inside of the boots then install them.

*When assembling the caliper and bracket, set the boot into the side pin groove.*

Assemble the caliper and bracket.

Install the brake disc guard and tighten the bolts to the specified torque.

**TORQUE: 6.8 N•m (0.7 kgf•m, 5.1 lbf•ft)**

## INSTALLATION

Temporarily install the brake hose eyelets to the caliper body with new sealing washers and oil bolts.  
Push the brake hose eyelets to the stopper on the caliper, then tighten the oil bolts to the specified torque.

**TORQUE: 34 N•m (3.5 kgf•m, 25 lbf•ft)**

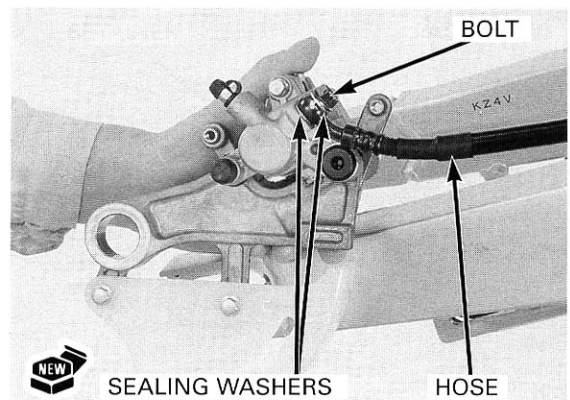
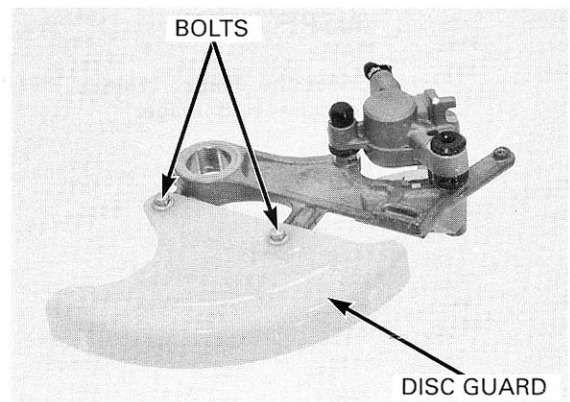
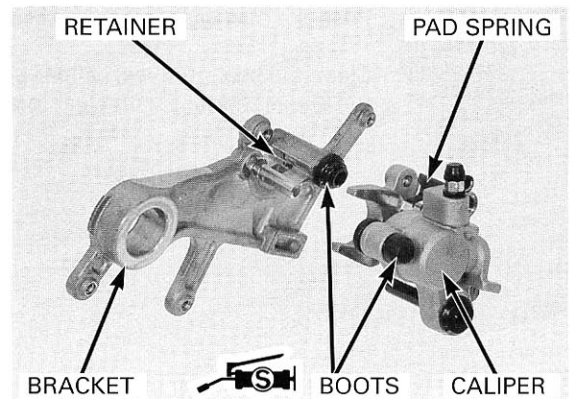
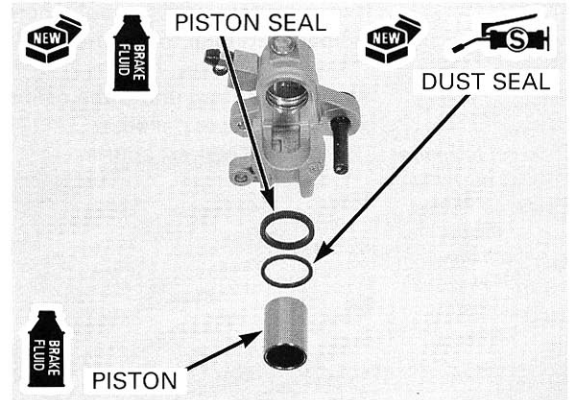

Install the caliper/bracket assembly onto the swingarm aligning the bracket tab with the slide rail on the swingarm.

Install the caliper guard and tighten the bolts securely (page 13-6).

Install the rear wheel (page 12-8).

Install the brake pad (page 13-7).

Fill and bleed the hydraulic system (page 13-4).

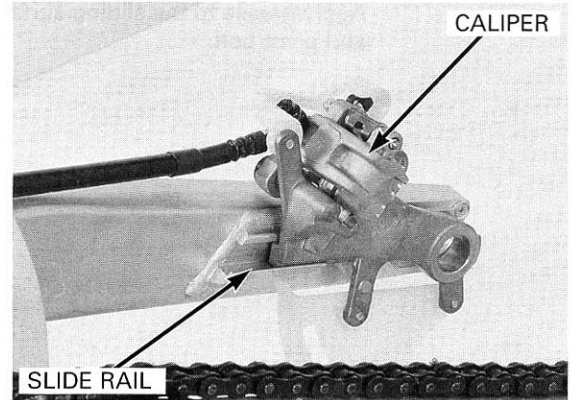

## BRAKE PEDAL

### REMOVAL

Remove the rear brake pedal pivot bolt and return spring.

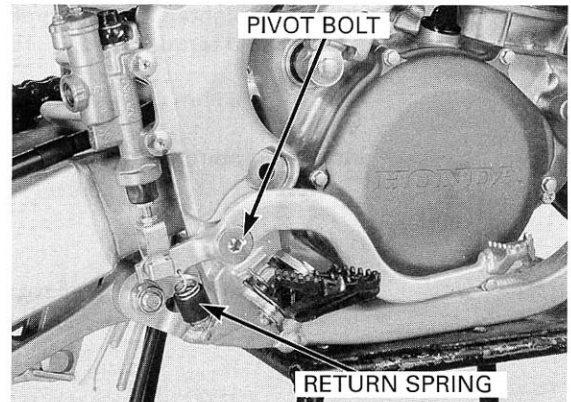

Remove and discard the cotter pin.  
Remove the joint pin.

Remove the brake pedal.

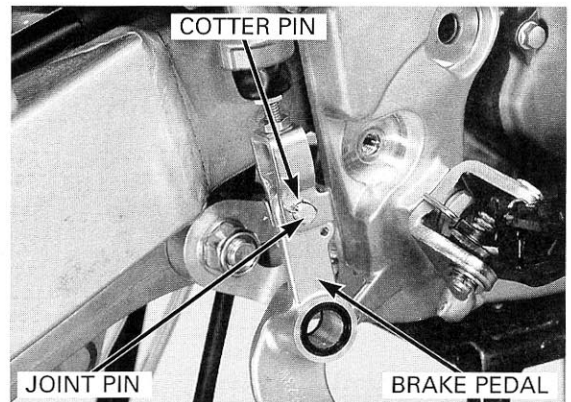

### INSTALLATION

Install the brake pedal joint and secure it with a new cotter pin.

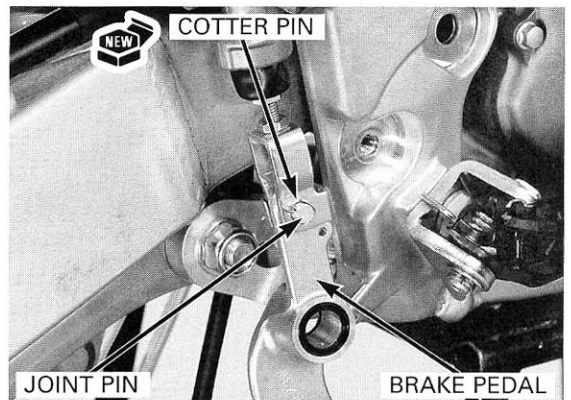

## HYDRAULIC BRAKE

---

Apply grease to the sliding surface of the brake pedal and pivot bolt.

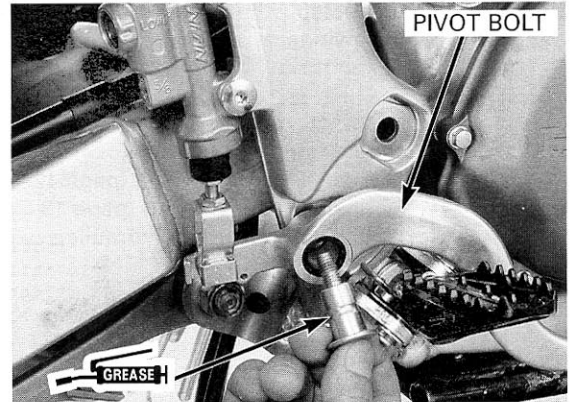

Install and tighten the rear brake pedal pivot bolt to the specified torque.

**TORQUE: 26 N·m (2.7 kgf·m, 20 lbf·ft)**

Install the return spring.

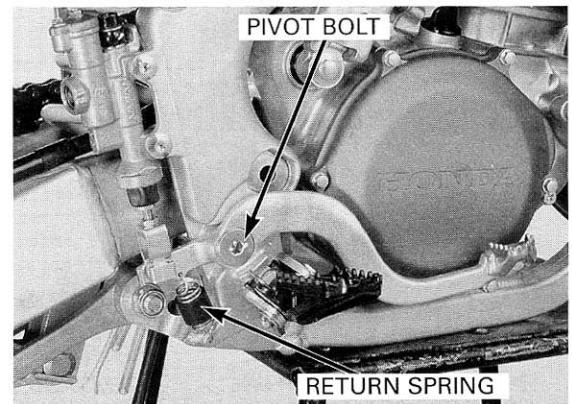

# IGNITION SYSTEM/ALTERNATOR

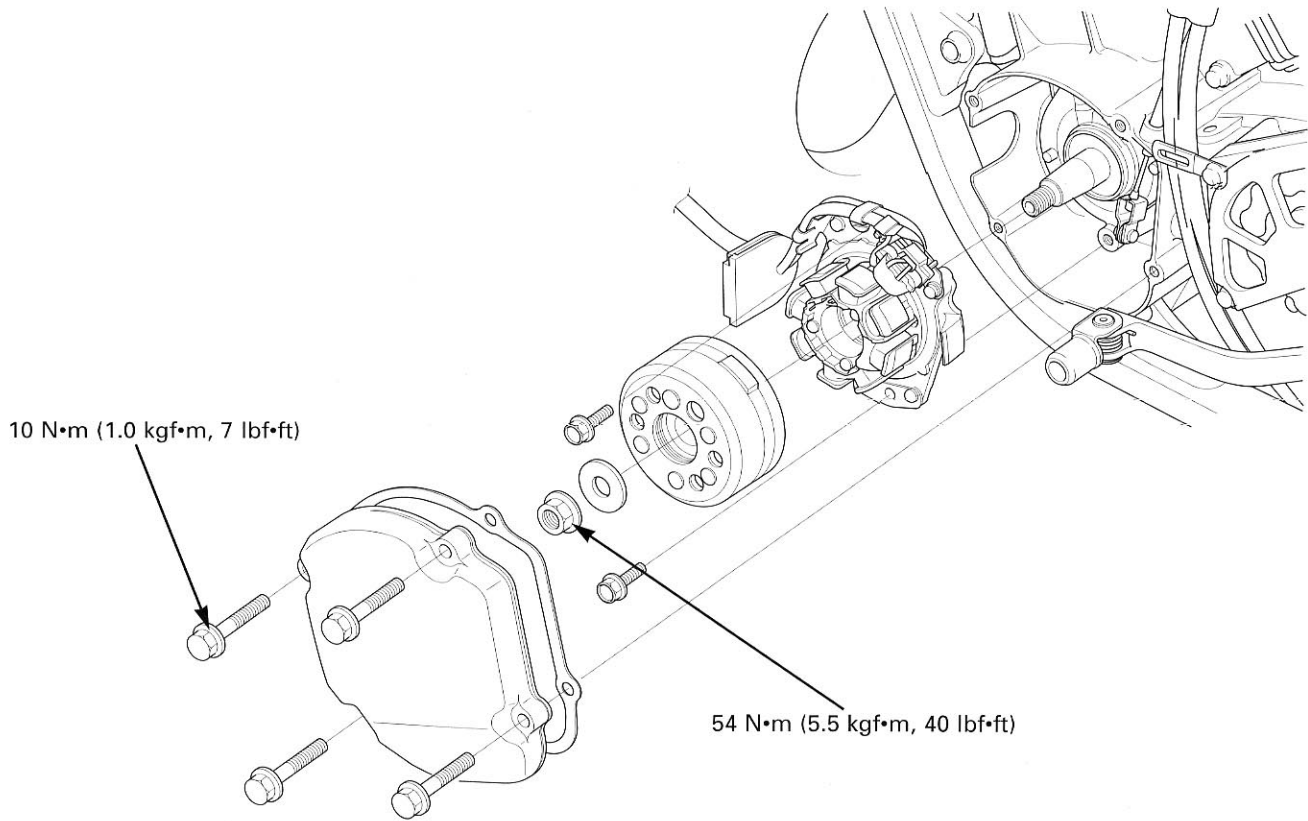
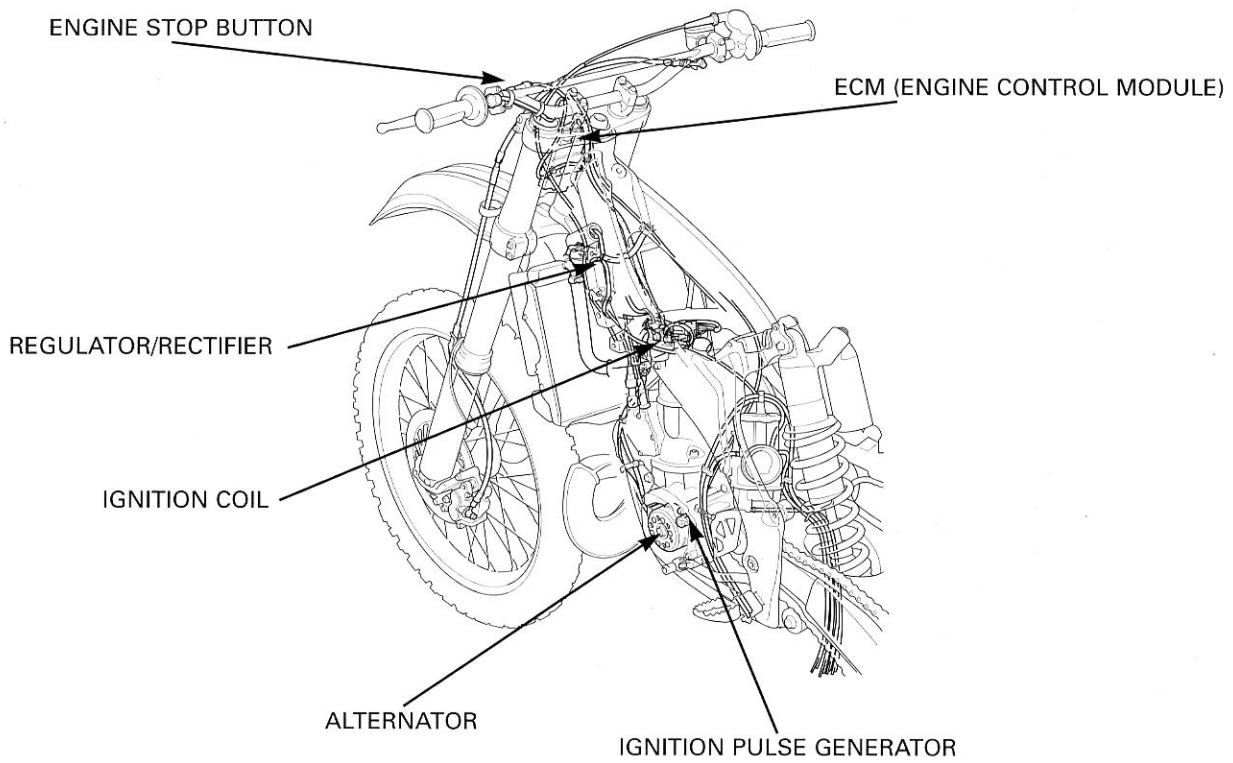

# 14. IGNITION SYSTEM/ALTERNATOR

SERVICE INFORMATION	14-1	IGNITION PULSE GENERATOR	14-7
TROUBLESHOOTING	14-2	ALTERNATOR	14-8
IGNITION SYSTEM INSPECTION	14-4	IGNITION TIMING	14-9
ENGINE CONTROL MODULE (ECM)	14-6	ENGINE STOP SWITCH	14-11
IGNITION COIL	14-6	REGULATOR/RECTIFIER	14-11
ALTERNATOR COIL	14-7		

## SERVICE INFORMATION

### GENERAL

- Some electrical components may be damaged if terminals or connectors are connected or disconnected improperly.
- When servicing the ignition system, always follow the steps in the troubleshooting sequence on page 14-3.
- The ignition timing cannot be adjusted since the Engine Control Module (ECM) is factory preset.
- The ECM may be damaged if dropped. Also, if the connector is disconnected when current is flowing, the excessive voltage may damage the ECM. Always turn the ignition switch to "OFF" before servicing.
- A faulty ignition system is often related to poorly connected or corroded connectors. Check connections before proceeding.
- Use a spark plug of the correct heat range. Using a spark plug with an incorrect heat range can damage the engine.

### SPECIFICATIONS

ITEM		SPECIFICATIONS
Spark plug	Standard (NGK)	BR8EG
	Standard (DENSO)	W24ESR-V
	Optional (NGK)	BR8EV
	Optional (DENSO)	W24ESR-G
Spark plug gap		0.5 – 0.6 mm (0.020 – 0.024 in)
Ignition coil resistance (at 20°C/68°F)	Primary	0.1 – 0.3 Ω
	Secondary with plug cap	9 – 16 Ω
	Secondary without plug cap	4 – 8 Ω
Ignition coil peak voltage		100 V minimum
Ignition pulse generator resistance (at 20°C/68°F)		180 – 280 Ω
Ignition pulse generator peak voltage		0.7 V minimum
Alternator coil resistance (at 20°C/68°F)		0.5 – 4 Ω
Ignition timing ("F" mark)	'02	18 ± 2° BTDC at 2,000 rpm
	After '02	20 ± 1° BTDC at 4,000 rpm

14

### TORQUE VALUES

Flywheel nut	54 N•m (5.5 kgf•m, 40 lbf•ft)
Alternator cover bolt	10 N•m (1.0 kgf•m, 7 lbf•ft)

## IGNITION SYSTEM/ALTERNATOR

---

### TOOLS

Peak voltage tester (Ignition mate: 08-0193, U.S.A. only) or  
Peak voltage adapter 07HGJ-0020100 with commercially available digital multimeter (impedance 10 M $\Omega$ /DCV minimum)  
Flywheel puller 07733-0010000 not available in U.S.A. or 07933-0010000  
Universal holder 07725-0030000

### TROUBLESHOOTING

- Inspect the following before diagnosing the system.
  - Faulty spark plug
  - Loose spark plug cap or spark plug wire connection
  - Water got into the spark plug cap (affecting the ignition coil secondary voltage)

**No spark at plug**

Unusual condition		Probable cause (Check in numerical order)
Ignition coil primary voltage	Low peak voltage	<ol style="list-style-type: none"> <li>1. Incorrect peak voltage adaptor connections (System is normal if measured voltage is over the specifications with reverse connection).</li> <li>2. The multimeter impedance is too low; below 10 MΩ/DCV.</li> <li>3. Cranking speed too slow.                             <ul style="list-style-type: none"> <li>• Kickstarter is weak</li> </ul> </li> <li>4. The sample timing of the tester and measured pulse were not synchronized (System is normal if measured voltage is over the standard voltage at least once).</li> <li>5. Poorly connected connectors or an open circuit in the ignition system.</li> <li>6. Faulty alternator coil.</li> <li>7. Faulty ignition coil.</li> <li>8. Faulty ECM (when above No.1 – 7 are normal).</li> </ol>
	No peak voltage	<ol style="list-style-type: none"> <li>1. Incorrect peak voltage adaptor connections (System is normal if measured voltage is over the specifications with reverse connection).</li> <li>2. Short circuit in engine stop switch wire.</li> <li>3. Faulty engine stop switch.</li> <li>4. Loose or poorly connected ECM connectors.</li> <li>5. An open circuit or loose connection in Green wire.</li> <li>6. Faulty alternator coil.</li> <li>7. Faulty ignition pulse generator (measure the peak voltage).</li> <li>8. Faulty ECM (when above No. 1 – 7 are normal).</li> </ol>
	Peak voltage is normal, but no spark jumps at plug	<ol style="list-style-type: none"> <li>1. Faulty spark plug or leaking ignition coil secondary current amperage.</li> <li>2. Faulty ignition coil.</li> </ol>
Ignition pulse generator	Low peak voltage	<ol style="list-style-type: none"> <li>1. The multimeter impedance is too low; below 10 MΩ/DCV.</li> <li>2. Cranking speed is too low                             <ul style="list-style-type: none"> <li>• Kickstarter is weak</li> </ul> </li> <li>3. The sampling timing of the tester and measured pulse were not synchronized (system is normal if measured voltage is over the standard voltage at least once).</li> </ol>
	No peak voltage	<ol style="list-style-type: none"> <li>1. Faulty peak voltage adaptor.</li> <li>2. Faulty ignition pulse generator.</li> </ol>

**IGNITION SYSTEM INSPECTION**

If there is no spark at the plug, check all connections for loose or poor contact before measuring each peak voltage.

Use the recommended digital multimeter or a commercially available digital multimeter with an impedance of 10 MΩ/DCV minimum.

The display value differs depending upon the internal impedance of the multimeter.

Connect the peak voltage adaptor to the digital multimeter.

**TOOLS:**

**Peak voltage tester**

(Ignition mate: 08-0193, U.S.A. only) or

**Peak voltage adaptor 07HGJ-0020100 with commercially available digital multimeter (impedance 10 MΩ/DCV minimum)**

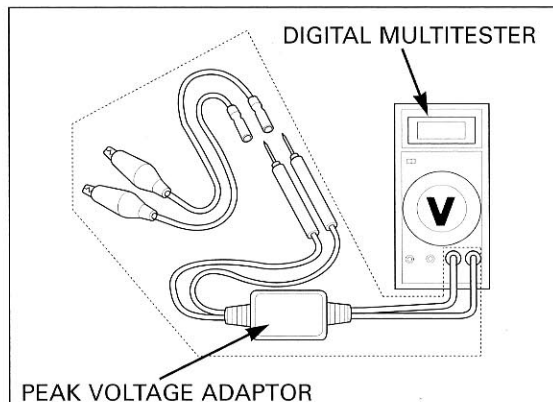

**IGNITION COIL PRIMARY PEAK VOLTAGE**

Check all system connections before inspection. If the system is disconnected, incorrect peak voltage might be measured.

Check cylinder compression and check that the spark plugs are installed correctly.

Shift the transmission into neutral and disconnect all spark plug caps from the spark plugs.

Connect known-good spark plugs to the spark plug caps and ground the spark plugs to the cylinder as done in a spark test.

With the ignition coil primary wire connected, connect the peak voltage adaptor or Imrie tester to the ignition coil.

**CONNECTION: Black/yellow (+) – Body ground (-)**

Crank the engine with the kickstarter and read the ignition coil primary peak voltage.

**PEAK VOLTAGE: 100V minimum**

If the peak voltage is abnormal, check for an open circuit or poor connection in the Black/yellow wires. If no defects are found in the harness, refer to the troubleshooting chart on page 14-3.

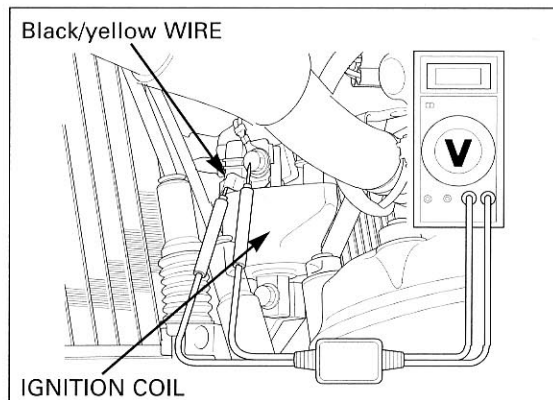
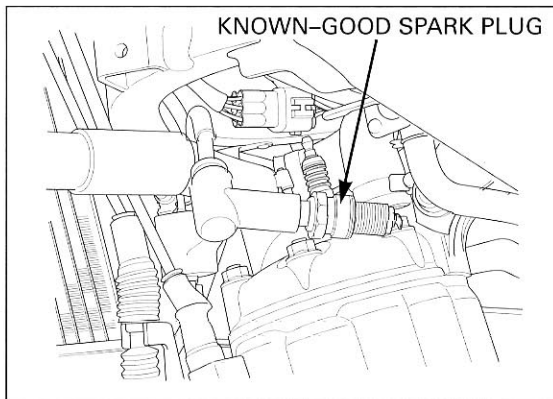



## IGNITION PULSE GENERATOR PEAK VOLTAGE

Remove the number plate (page 2-3).

Check cylinder compression and check that the spark plug is installed correctly.

Disconnect the ECM 4P black connector.

Connect the peak voltage adaptor probes to the connector terminals of the wire harness side.

### TOOLS:

**Peak voltage tester**

(Ignition mate: 08-0193, U.S.A. only) or

**Peak voltage adaptor 07HGJ-0020100 with commercially available digital multimeter (impedance 10 M $\Omega$ /DCV minimum)**

**CONNECTION: Blue/yellow (+) – Green/white (-)**

Crank the engine with the kickstarter and read the peak voltage.

**PEAK VOLTAGE: 0.7 V minimum**

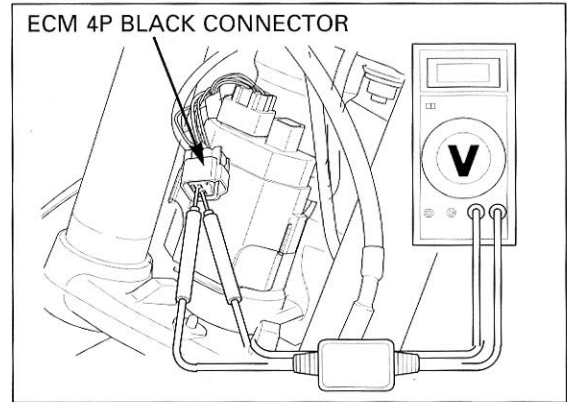

If the peak voltage measured is abnormal, recheck the following:

Disconnect the alternator 4P black connector.

Connect the peak voltage adapter to the terminals of the ignition pulse generator side and recheck the peak voltage.

If the peak voltage at the ECM 4P black connector is abnormal and peak voltage at the alternator 4P connector is normal, check for poorly connected connectors or a broken wire harness.

If the peak voltage is abnormal at both connectors, follow the checks described in the troubleshooting. If all items are normal, the ignition pulse generator is faulty. See page 14-8 for ignition pulse generator replacement.

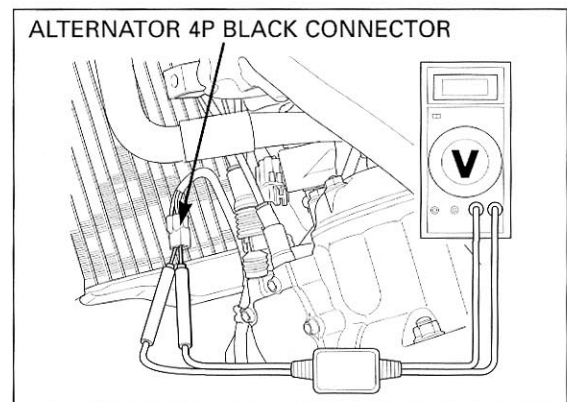

### ENGINE CONTROL MODULE (ECM)

#### SYSTEM INSPECTION

Remove the number plate (page 2-3).

Disconnect the ECM 4P black and 8P black connectors.

Inspect the following at the ECM 4P black and 8P black connectors wire harness side.

- Servo motor (page 8-6)
- Ignition coil (page 14-6)
- Engine stop switch (page 14-11)
- Regulator/rectifier (page 14-11)
- Alternator coil (page 14-7)
- Ignition pulse generator (page 14-7)

Replace the ECM if all components are normal.

#### REMOVAL/INSTALLATION

Remove the number plate (page 2-3).

Disconnect the ECM 4P black and 8P black connectors.  
Remove the ECM from the rubber case.

Installation is in the reverse order of removal.

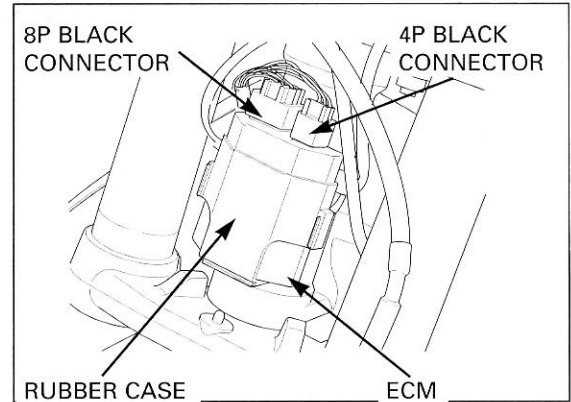

### IGNITION COIL

#### INSPECTION

Remove the radiator shroud (page 2-3).

Remove the spark plug cap.  
Disconnect the ignition coil primary wire.  
Measure the ignition primary coil resistance between the primary terminal and body ground.

**STANDARD: 0.1 – 0.3  $\Omega$  (20 °C/68 °F)**

If resistance is out of the specified range, replace the ignition coil (page 14-7).

Measure the ignition secondary coil resistance between the primary terminal and plug cap.

**STANDARD: 9 – 16  $\Omega$  (20 °C/68 °F)**

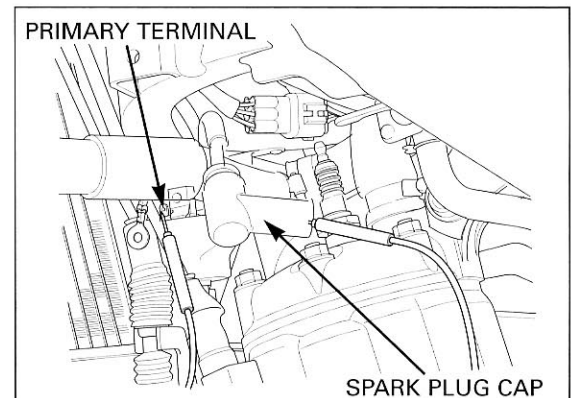
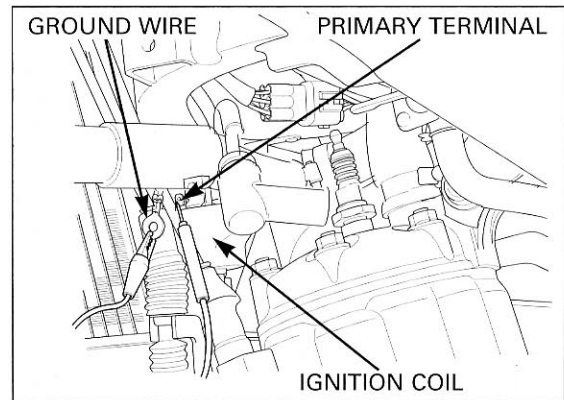

If resistance is out of the specified range, remove the spark plug cap and measure the ignition secondary coil resistance between the primary terminal and spark plug wire.

**STANDARD: 4 – 8  $\Omega$  (20 °C/68 °F)**

If resistance is out of the specified range, replace the ignition coil (see below).

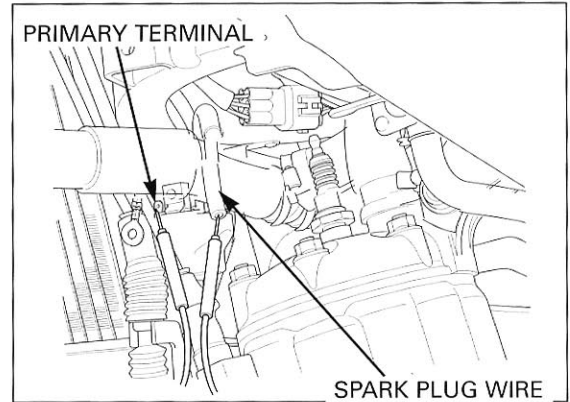

## REMOVAL/INSTALLATION

Remove the radiator shroud (page 2-3).

Remove the spark plug cap.  
Disconnect the ignition coil primary wire.  
Remove the bolts and ignition coil.

*When installing the ignition coil, make space with the upper radiator hose.*

Installation is in the reverse order of removal.

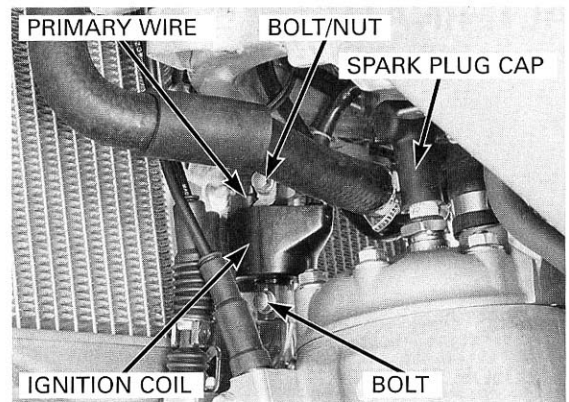

## ALTERNATOR COIL

### INSPECTION

Remove the radiator shroud (page 2-3).

Disconnect the alternator 4P connector.  
Measure the resistance between the Yellow and White terminals of the wire harness side.

**STANDARD: 0.5 – 4  $\Omega$  (20 °C/68 °F)**

If resistance is out of the specified range, replace the stator (page 14-8).

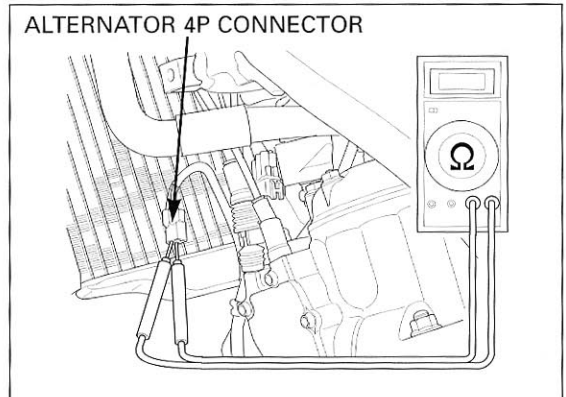

## IGNITION PULSE GENERATOR

### INSPECTION

Remove the number plate (page 2-3).

Disconnect the ECM 4P black connector.  
Measure the resistance between the Blue/yellow and Green/white terminals of the wire harness side.

**STANDARD: 180 – 280  $\Omega$  (20 °C/68 °F)**

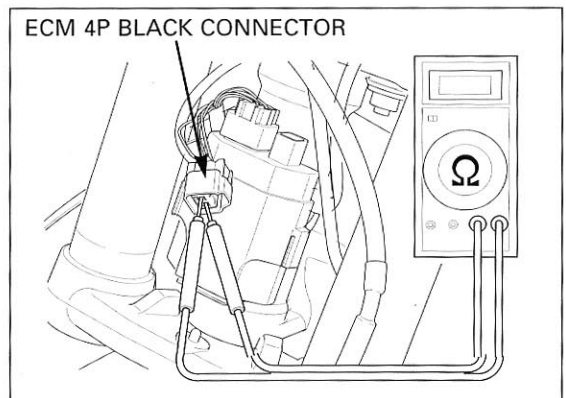

## IGNITION SYSTEM/ALTERNATOR

If the resistance is out of the specified range, recheck the following:

Disconnect the alternator 4P black connector.  
Measure the resistance between the Blue/yellow and Green/white terminals of the wire harness side.

If the resistance at the ECM 4P black connector is abnormal and resistance at the alternator 4P connector is normal, check for poorly connected connectors or a broken wire harness.

If the resistance is abnormal at both connectors, the ignition pulse generator is faulty. See below for stator replacement.

ALTERNATOR 4P CONNECTOR

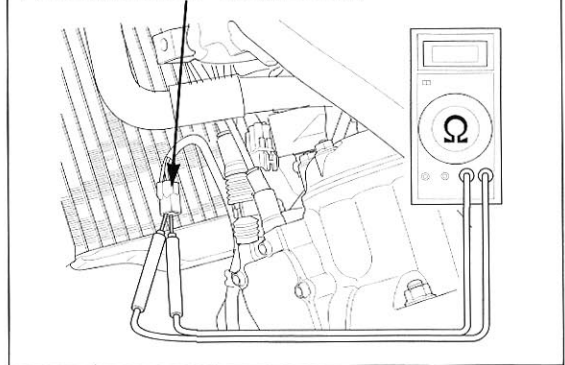

## ALTERNATOR

### REMOVAL

Disconnect the alternator 4P black connector.  
Remove the alternator wire from the wire clamp.

Remove the bolts, alternator cover and gasket.

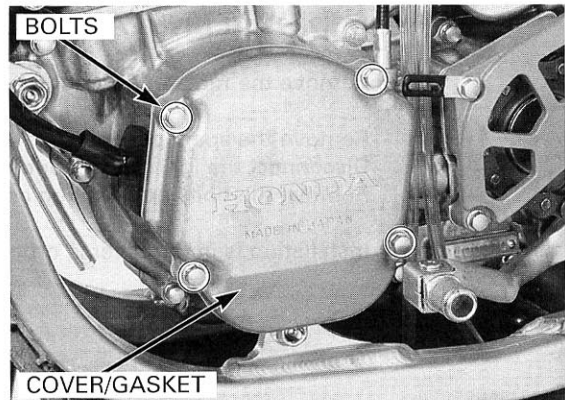

Hold the flywheel with the universal holder and remove the nut and washer.

**TOOL:**

Universal holder

07725-0030000

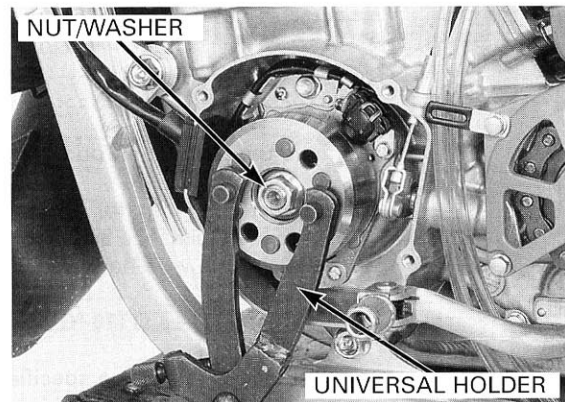

Remove the flywheel using the flywheel puller.

**TOOL:**

Flywheel puller

07733-0010000  
not available in U.S.A. or  
07933-0010000

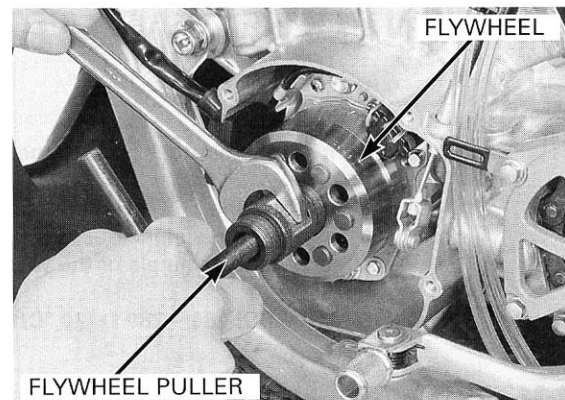

Remove the grommet, woodruff key, bolts and stator.

**INSTALLATION**

*When you replace the flywheel, stator or ECM, check and adjust the ignition timing (page 14-10).*

Install the woodruff key in the groove on the crankshaft.  
 Install the stator and tighten the bolts securely.  
 Install the grommet to the groove on the left crankcase.

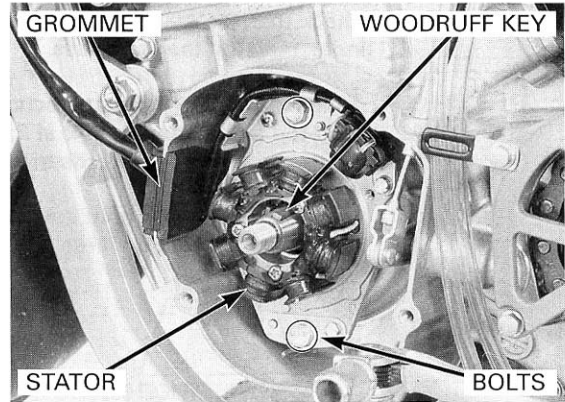

Install the flywheel to the crankshaft aligning the groove in the flywheel and woodruff key.

Install the washer and nut.  
 Hold the flywheel with the universal holder and tighten the nut to the specified torque.

**TOOL:**  
**Universal holder**                      **07725-0030000**

**TORQUE: 54 N·m (5.5 kgf·m, 40 lbf·ft)**

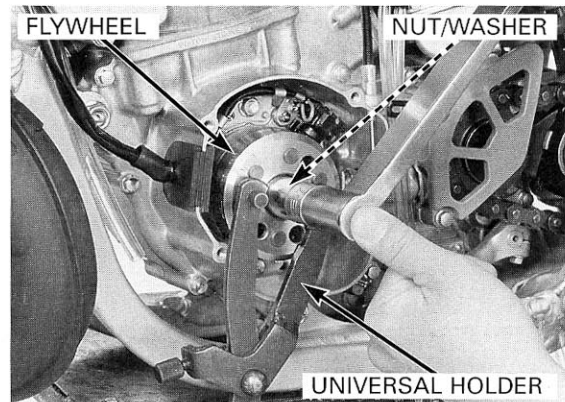

Install the new gasket to the alternator cover.

Install the alternator cover and tighten the bolts to the specified torque.

**TORQUE: 10 N·m (1.0 kgf·m, 7 lbf·ft)**

Install the alternator wire to the wire clamp.  
 Connect the alternator 4P black connector.

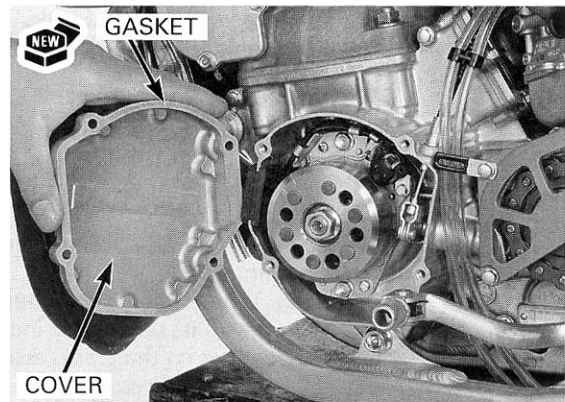

**IGNITION TIMING**

The ignition timing is factory preset and only needs to be checked when an electrical system component is replaced.

Warm-up the engine to normal operating temperature.  
 Stop the engine.

Remove the alternator cover (page 14-8).

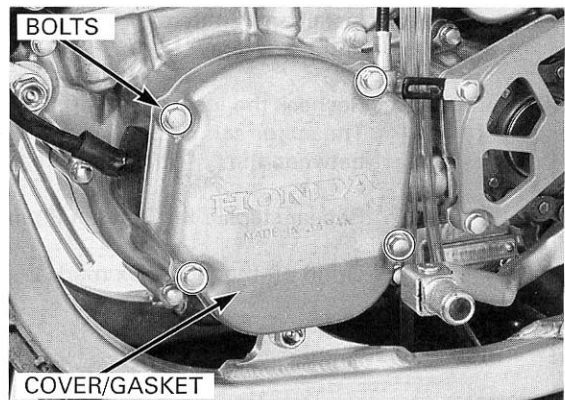

## IGNITION SYSTEM/ALTERNATOR

Check that the stator index mark is aligned with the index mark on the crankcase.

Attach the timing light and tachometer.

'02: Start the engine and hold it at 2,000 rpm while pointing the timing light towards the index mark.

After '02: Start the engine and hold it at 4,000 rpm while pointing the timing light towards the index mark.

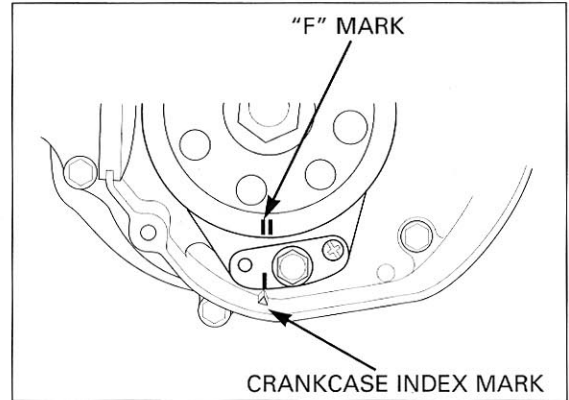

If the stator's original index mark aligns between the "F" marks, the engine is timed correctly. Remove the testing equipment and reassemble the motorcycle.

If the stator's original index mark does not align between the "F" marks, scribe a temporary index mark on the stator setting plate that will align between the "F" marks at 2,000 rpm (After '02: 4,000 rpm).

Stop the engine and do following:

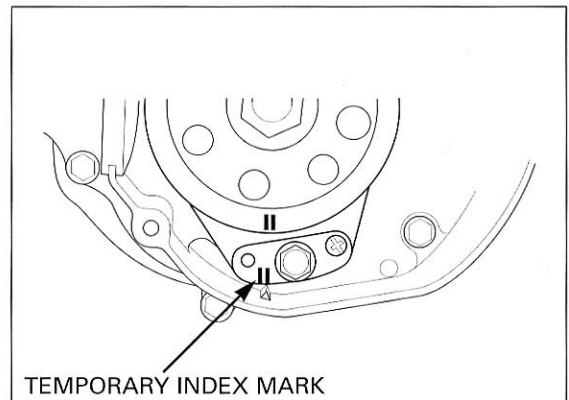

- This procedure is to be done after replacing the ECM, ignition pulse generator/stator assembly or flywheel.
- If you have checked the ignition timing as a troubleshooting method and the marks did not align, inspect the ECM, ignition pulse generator and stator, before performing this procedure.

Remove the stator mounting bolts, setting plate screw and setting plate.

Elongate the setting plate mounting bolt hole, then reinstall it with its temporary index mark aligned with the index mark on the crankcase.

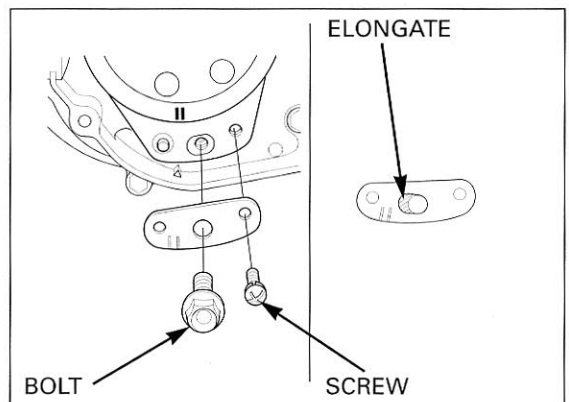

Install and tighten the stator mounting bolts and setting plate screw.

Recheck the ignition timing.

The stator setting plate index mark should now align between the "F" marks on the flywheel.

Repeat steps if the ignition timing is not correct.

Grind off the old index mark.

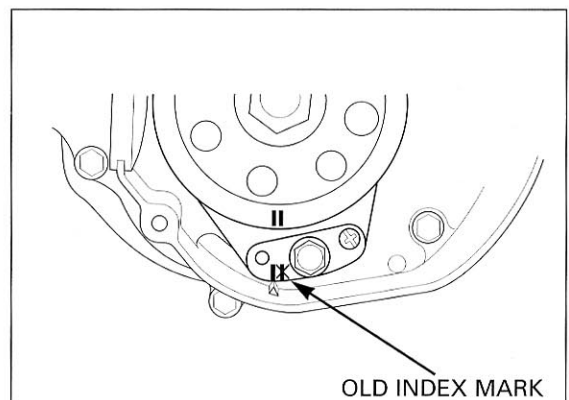

## ENGINE STOP SWITCH

### INSPECTION

Remove the number plate (page 2–3).

Disconnect the ECM 8P black and 4P black connectors. Check for continuity at the Black/white and Green terminals of the wire harness side with the engine stop switch button pressed. There should be no continuity when the button is not pushed.

If the specification is abnormal, recheck the following:  
Disconnect the engine stop switch connectors.

Check the engine stop switch for continuity with the switch button pressed. There should be no continuity when the button is not pushed.

If the specification at the ECM 8P black and 4P black connector is abnormal and specification at the engine stop switch connectors is normal, check for poorly connected connectors or a broken wire harness. If the specification is abnormal at both connectors, the engine stop switch is faulty. See page 11–27 for engine stop button replacement.

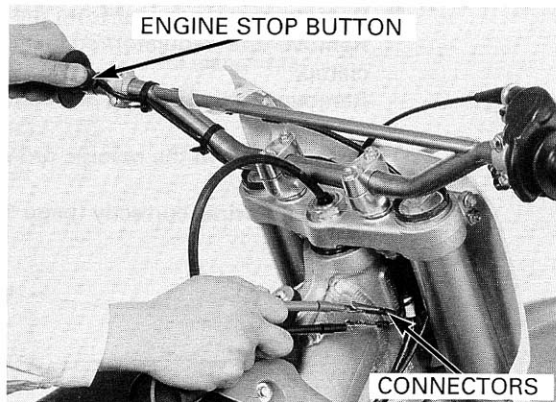
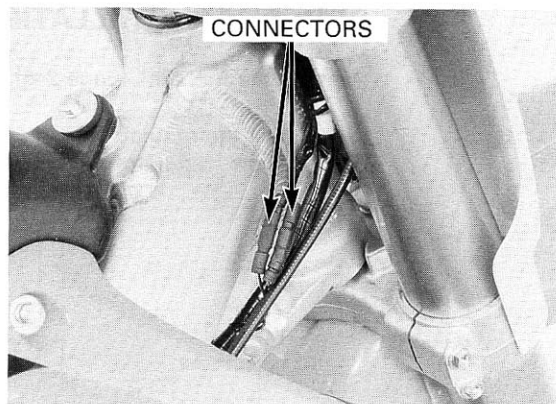
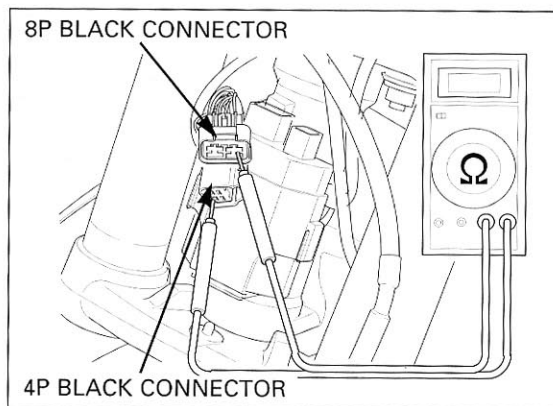

## REGULATOR/RECTIFIER

### INSPECTION

#### VOLTAGE INSPECTION

Remove the number plate (page 2–3).

Disconnect the ECM 8P black connector. Measure the voltage at the ECM 8P black connector wire harness side. Crank the engine with kickstarter.

**CONNECTION:** Red (+) — Green (–)  
**STANDARD:** 5 V minimum

If the voltage measured is abnormal, see page 14–12.

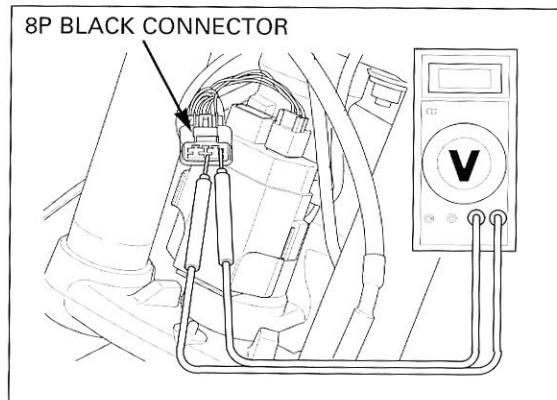

## IGNITION SYSTEM/ALTERNATOR

Remove the fuel tank (page 2-5).

Disconnect the regulator/rectifier 4P connector.  
Check for continuity between the ECM 8P black connector wire harness side and the regulator/rectifier 4P connector wire harness side.

**CONNECTION: Red — Red**  
**Green — Green**  
**Standard: Continuity**

If there is no continuity, check for poorly connected connectors or a broken wire harness.  
If there is continuity, replace the regulator/rectifier.

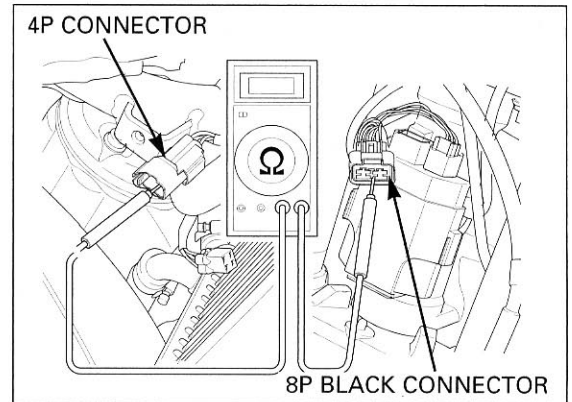

### REMOVAL/INSTALLATION

Remove the fuel tank (page 2-5).

Disconnect the regulator/rectifier 4P connector.  
Remove the regulator/rectifier wire from the wire band.

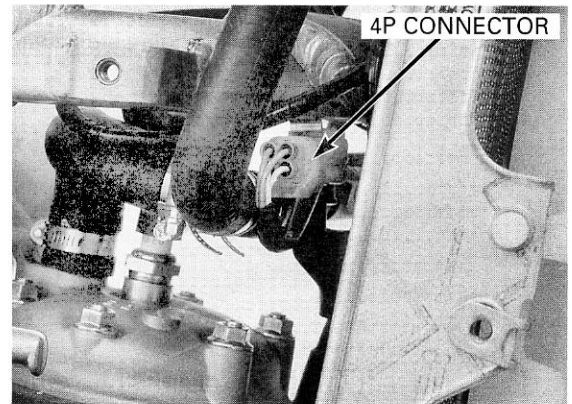

Remove the condenser from the tab on the frame.  
Remove the regulator/rectifier wire from the wire clamp.  
Remove the bolt, clamp and regulator/rectifier unit.

Installation is in the reverse order of removal.

Route the wires correctly (page 1-17).

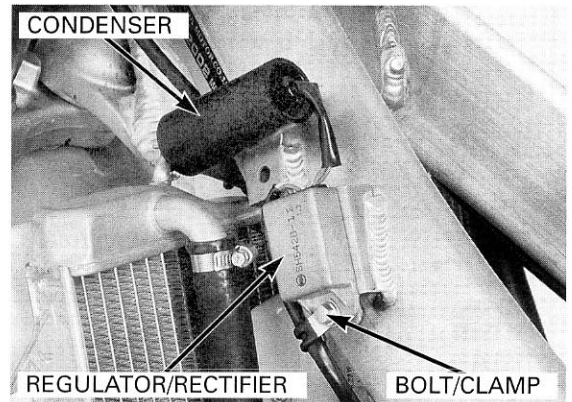



# 15. WIRING DIAGRAM

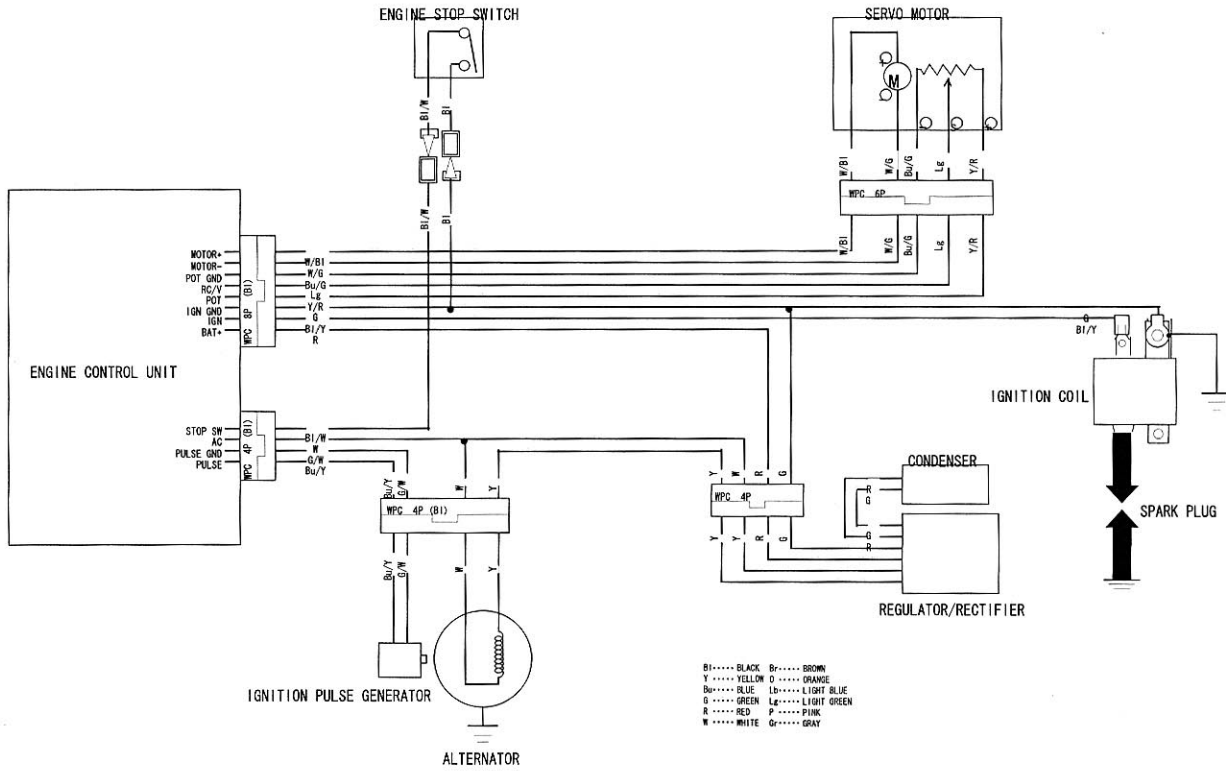

# 16. TECHNICAL FEATURES

## RC VALVE

To maximize 2-cycle engine output, engineers determine the ideal cylinder port timing and then increase the crankcase chamber's intake pumping efficiency by using the exhaust gas pulses as they pass through the exhaust chamber.

Significant increases in 2-cycle engine output are possible by varying the exhaust timing according to the engine's speed. Honda has added an electronically controlled RC valve to address this need. The ECM controls RC valve operation. The RC valve's servo motor controls RC valve operation. The RC valve's servo motor is attached to the exhaust port flap valves, which based on rpm, varies the exhaust timing. When engine speed is below 3,000 rpm the RC valve partially restricts the exhaust port. As the engine speed varies between 3,000 and 8,000 rpm, the RC valve will change exhaust port timing in relation to the rpm, closely mating the demands of the rider. Above 8,000 rpm, the RC valve fully opens the exhaust port, providing maximum output.

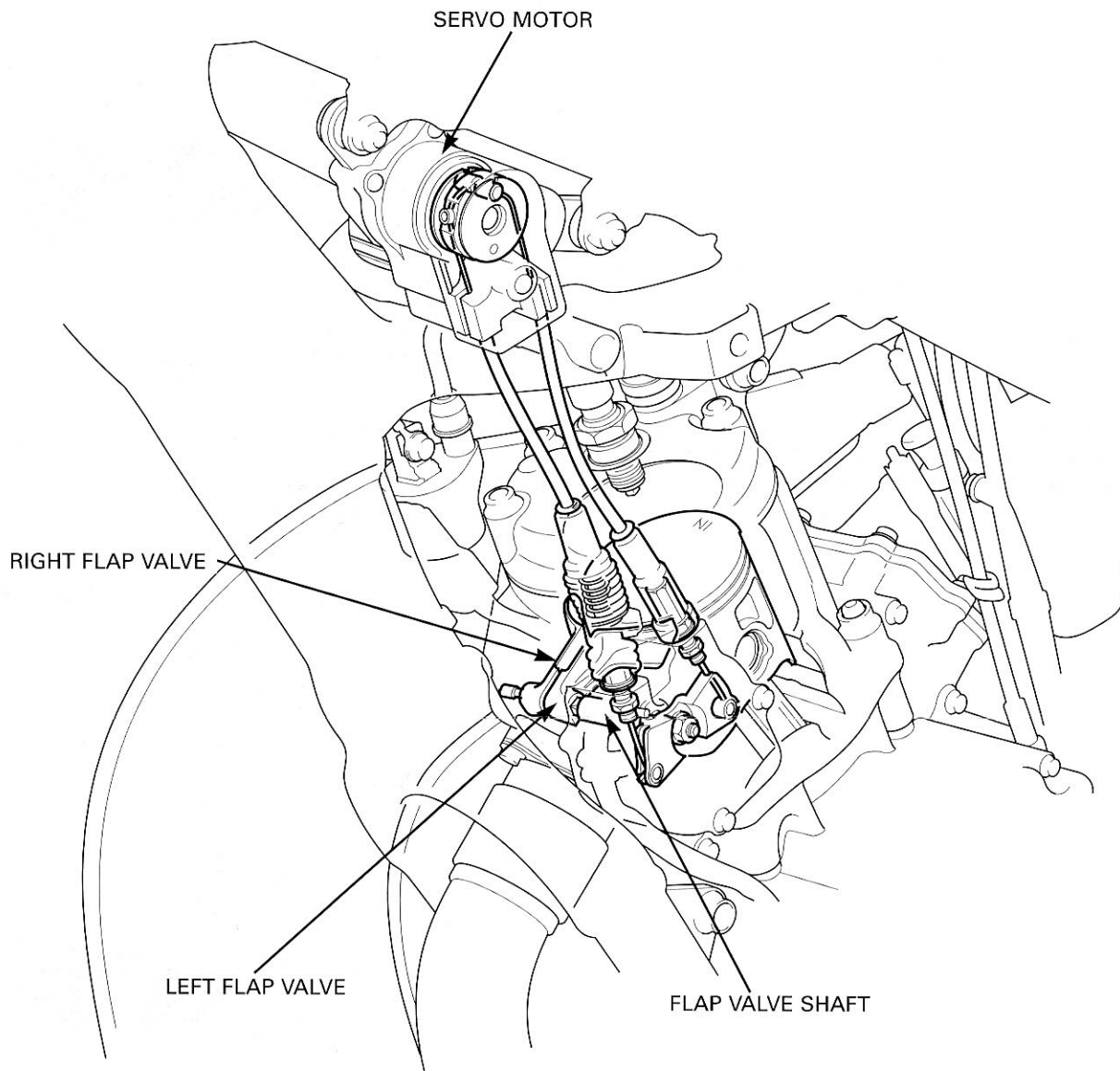

## TECHNICAL FEATURES

When the engine is running below 3,000 rpm, the servo motor operates the RC valve control cables and the flap valve shaft, closing the flap valves. As a result the exhaust port timing is retarded and the port volume is reduced.

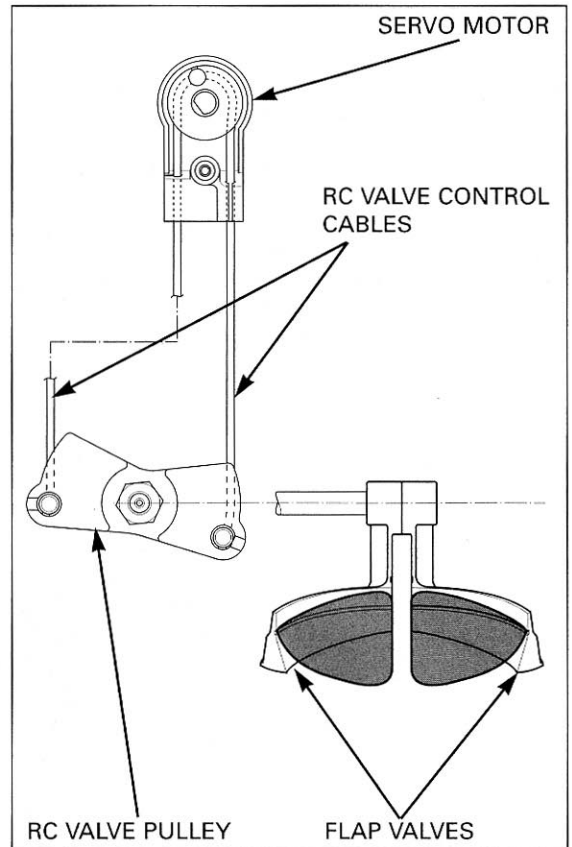

When the engine is running above 8,000 rpm, the servo motor operates the RC valve control cables and the flap valve shaft, opening the flap valves fully. As a result the exhaust port timing is advanced and the port volume is increased.

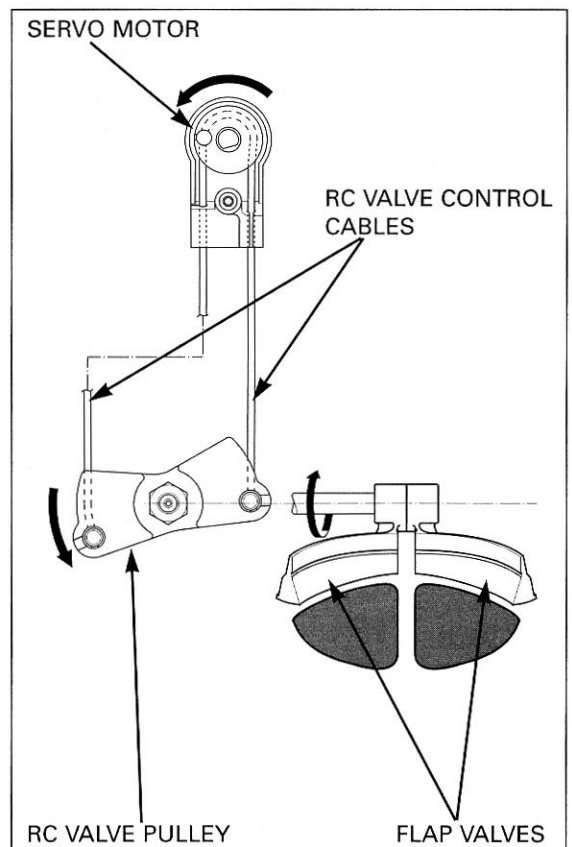

# FRONT SUSPENSION

## GENERAL

Energy absorption, tracking ability, and ride comfort are the three main criteria for off-road suspension. To achieve these criteria, an inverted fork with separate compression chamber has been developed.

The three main features of this type of fork are:

1. The fork damper is located at the top of the fork. The spring is located at the bottom. This is the reverse of a conventional fork and allows the chamber (between the fork damper and the outer pipe) to generate stable, consistent damping force, resulting in greater energy absorption.
2. Oil in the fork is completely isolated from the oil inside the fork damper. This design prevents air bubbles that may form in the oil from entering the fork damper, ensuring that the damper provides stable damping force at all times.
3. The fork damper is air bled and compressed by a spring. This feature provides ride comfort and reduces the amount of air that can form bubbles when the fork is repeatedly compressed and released. These air bubbles reduce the effectiveness of the fork oil damping.

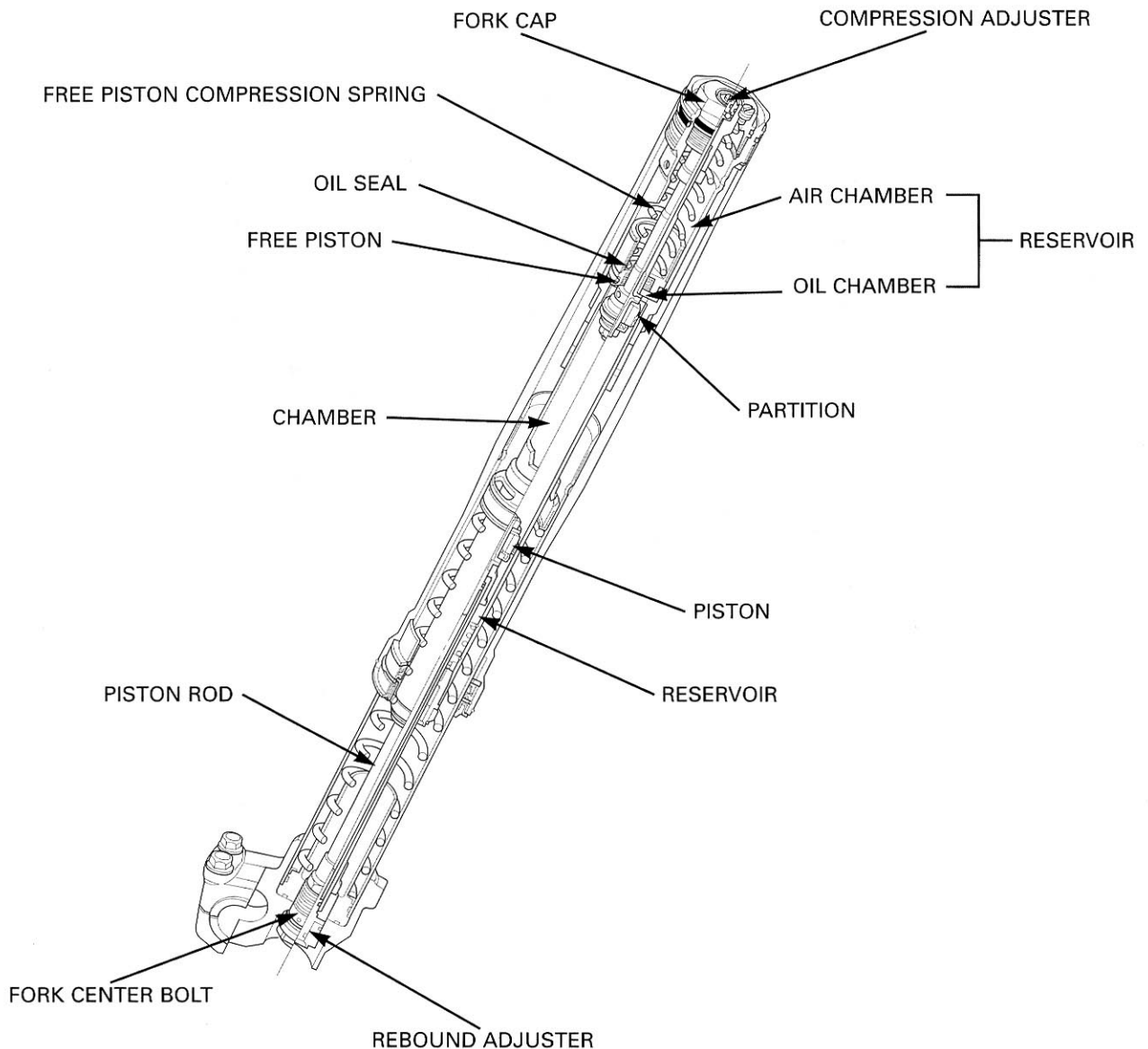

## TECHNICAL FEATURES

### FORK DAMPER

In conventional forks, the fork oil mixes with the air inside of the fork due to damper operation and bubbles are created. The penetration of fork oil mixed with the bubbles into the fork damper decreases or delays damping force generation.

The twin chamber type fork damper has upper and lower oil seals to completely separate the oil inside of the damper from the oil outside of the damper. Also, when assembling the fork, the fork damper is air bled, and the oil chamber and the air chamber are compressed by the free piston compression spring. The oil in the damper is completely isolated from the outside oil and air.

Also, the adjusters (damping force adjusting system) have adjustable passages fitted on the piston, and the partitions enable the rider to adjust the damping force according to their preferences and the track conditions.

### OUTER PIPE

The fork damper intrudes into the oil in the fork during compression of the fork. Then, the flow of oil through the oil passages in the spring seat located outside of the damper causes damping force.

This damping force is generated from the middle to the end of the fork stroke where the spring seat intrudes into the oil, further supporting the damping of the fork.

### OIL FLOW

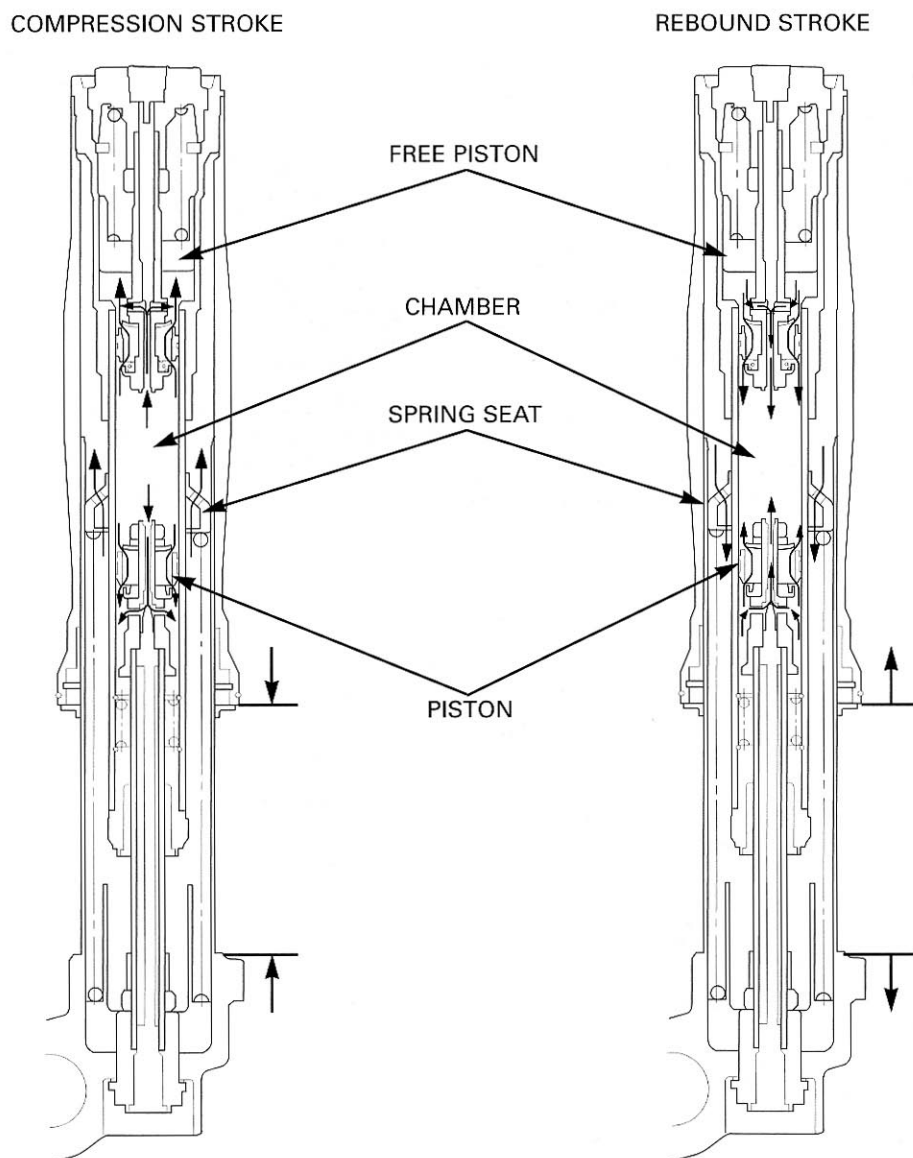

# 17. TROUBLESHOOTING

<b>ENGINE DOES NOT START OR IS HARD TO START</b>	<b>17-1</b>	<b>POOR PERFORMANCE AT HIGH SPEED</b>	<b>17-4</b>
<b>ENGINE LACKS POWER</b>	<b>17-2</b>	<b>POOR HANDLING</b>	<b>17-4</b>
<b>POOR PERFORMANCE AT LOW AND IDLE SPEED</b>	<b>17-3</b>		

## ENGINE DOES NOT START OR IS HARD TO START

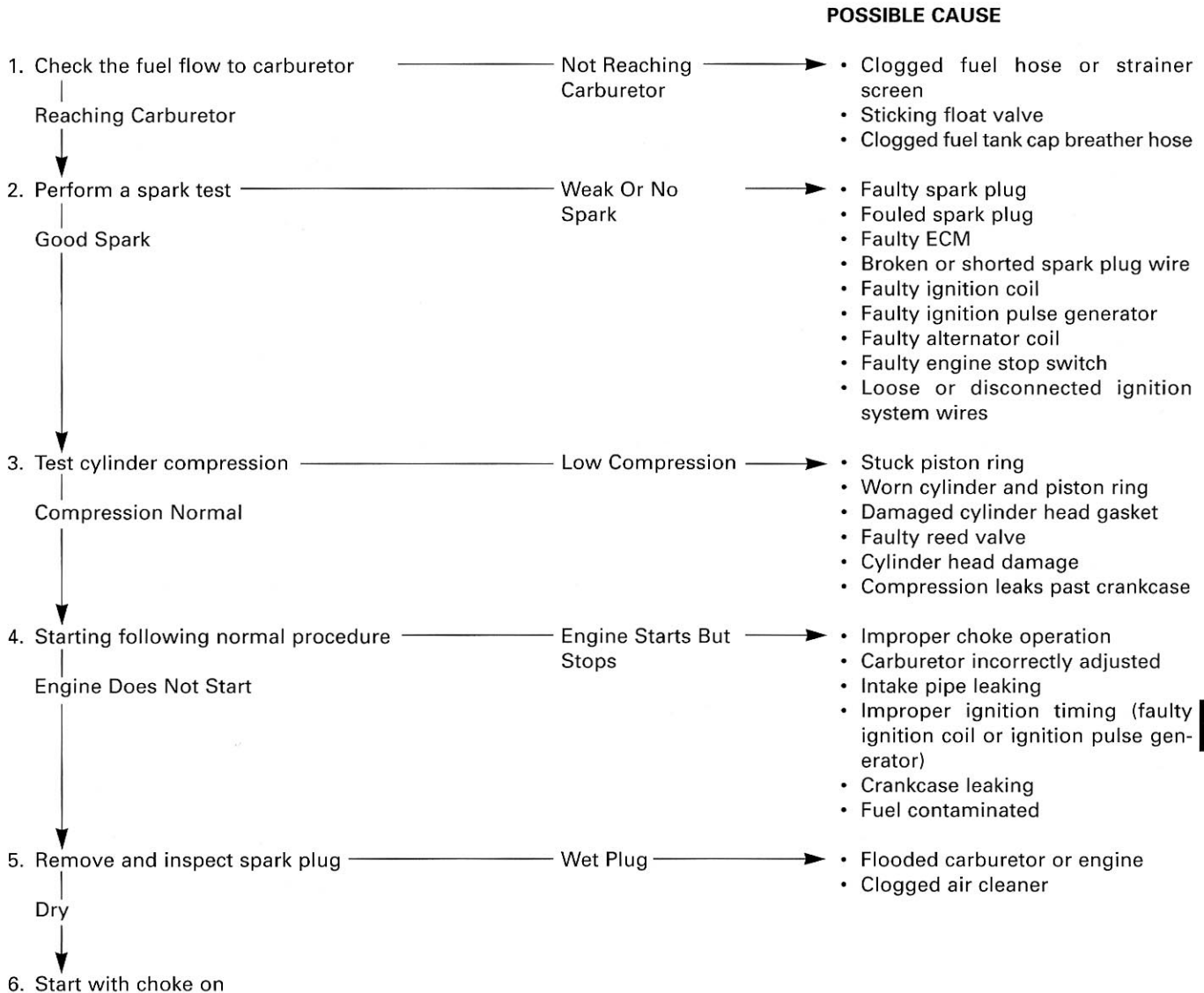

**ENGINE LACKS POWER**

**POSSIBLE CAUSE**

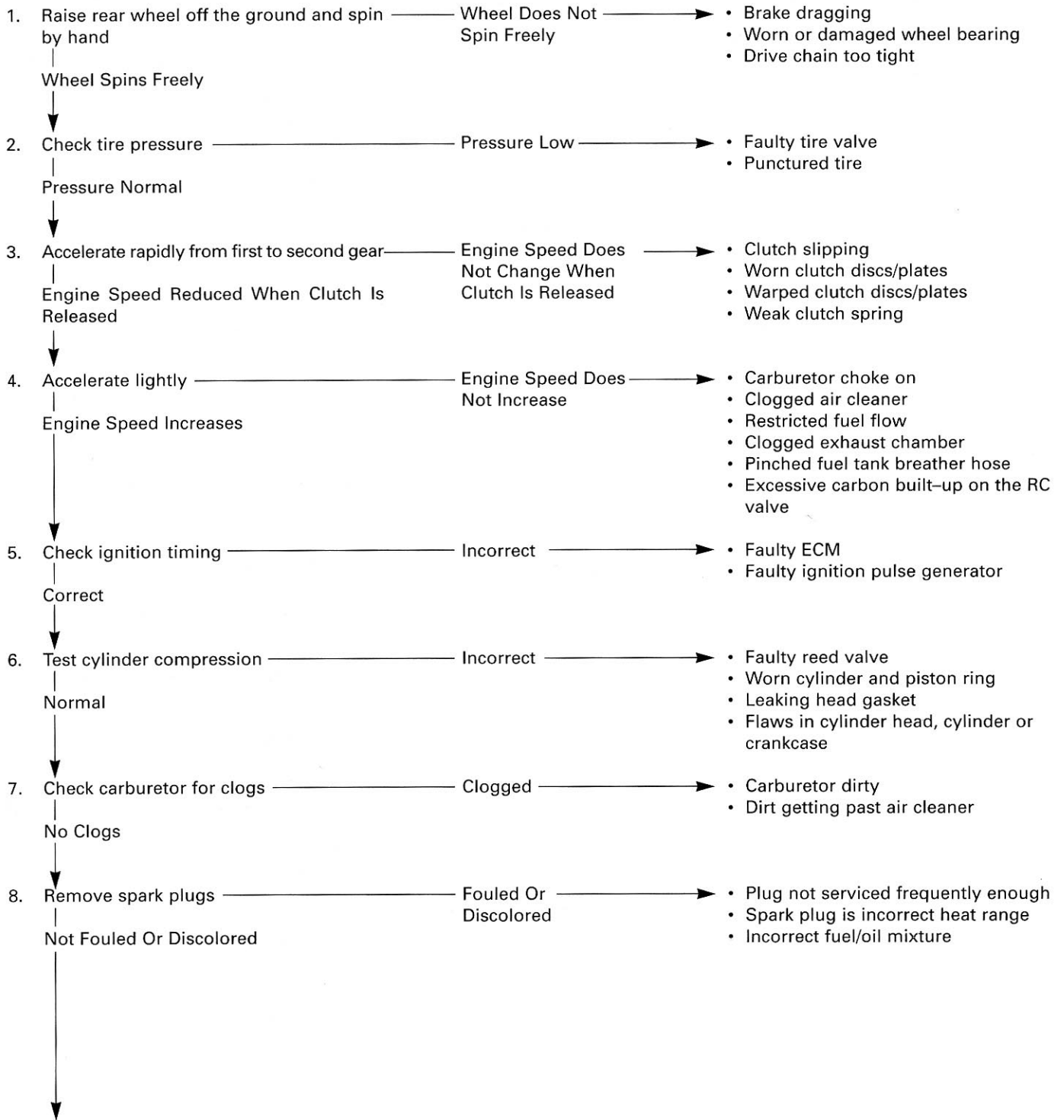

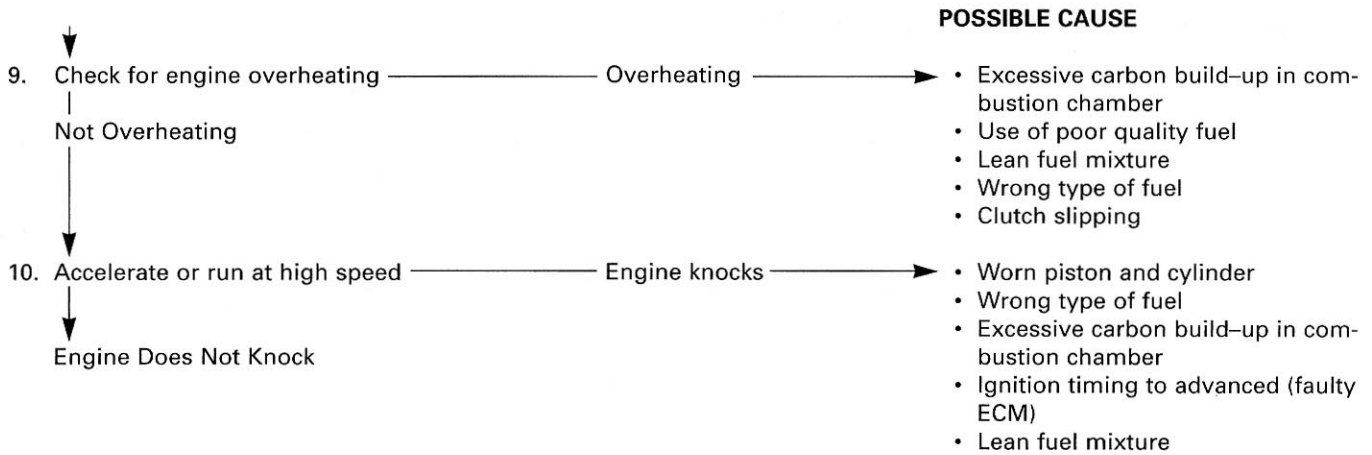

**POOR PERFORMANCE AT LOW AND IDLE SPEED**

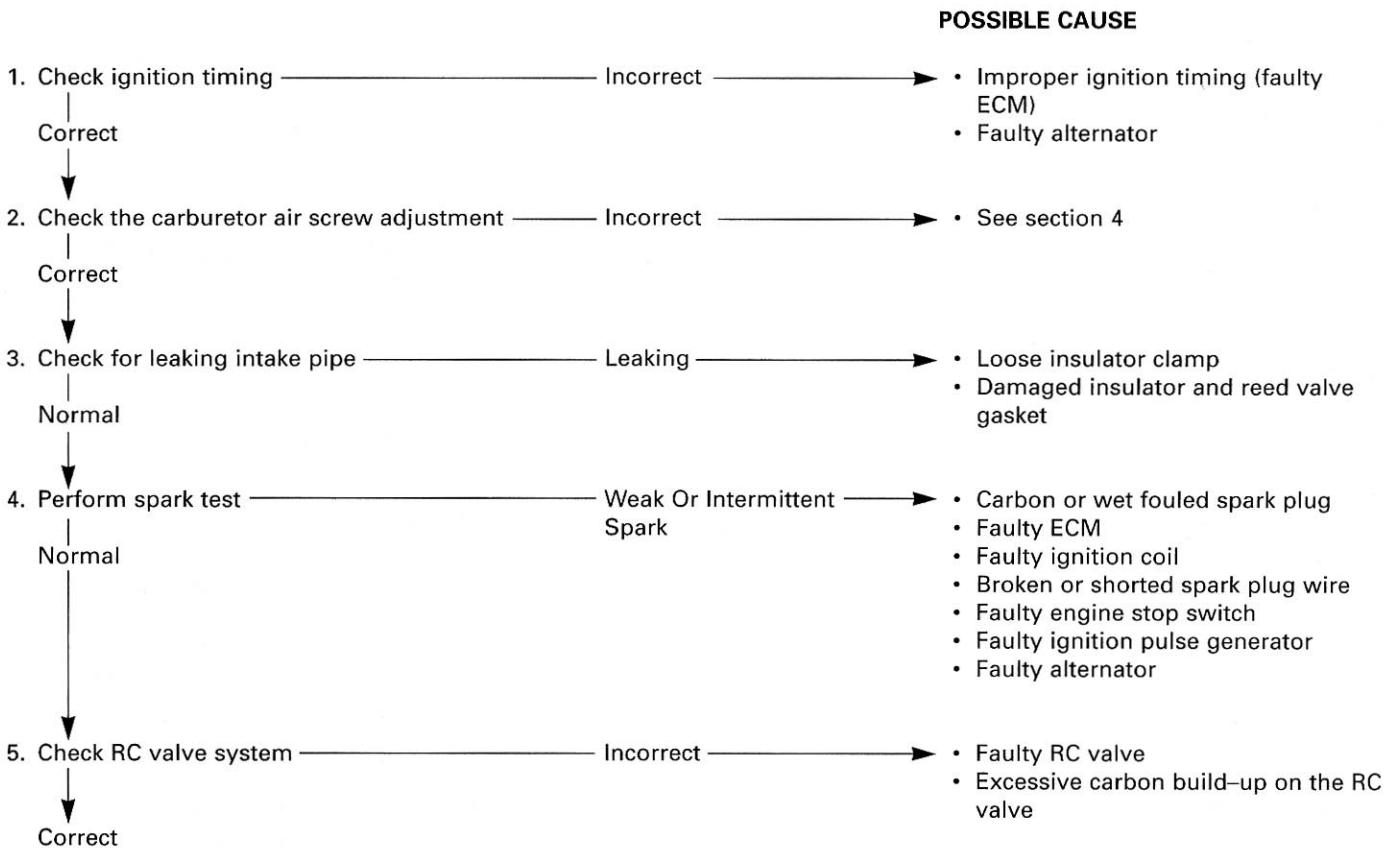



## TROUBLESHOOTING

---

### POOR PERFORMANCE AT HIGH SPEED

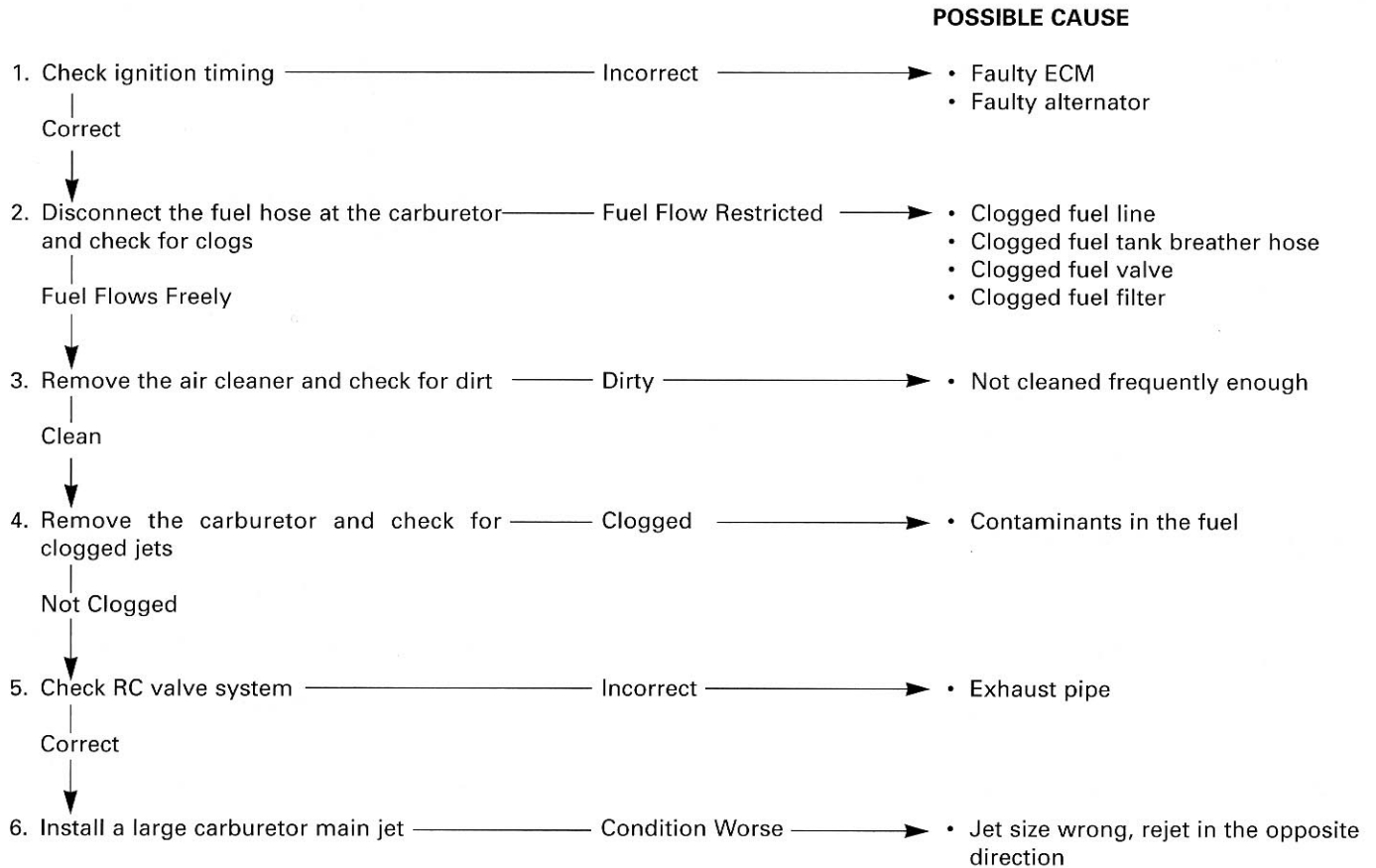

### POOR HANDLING

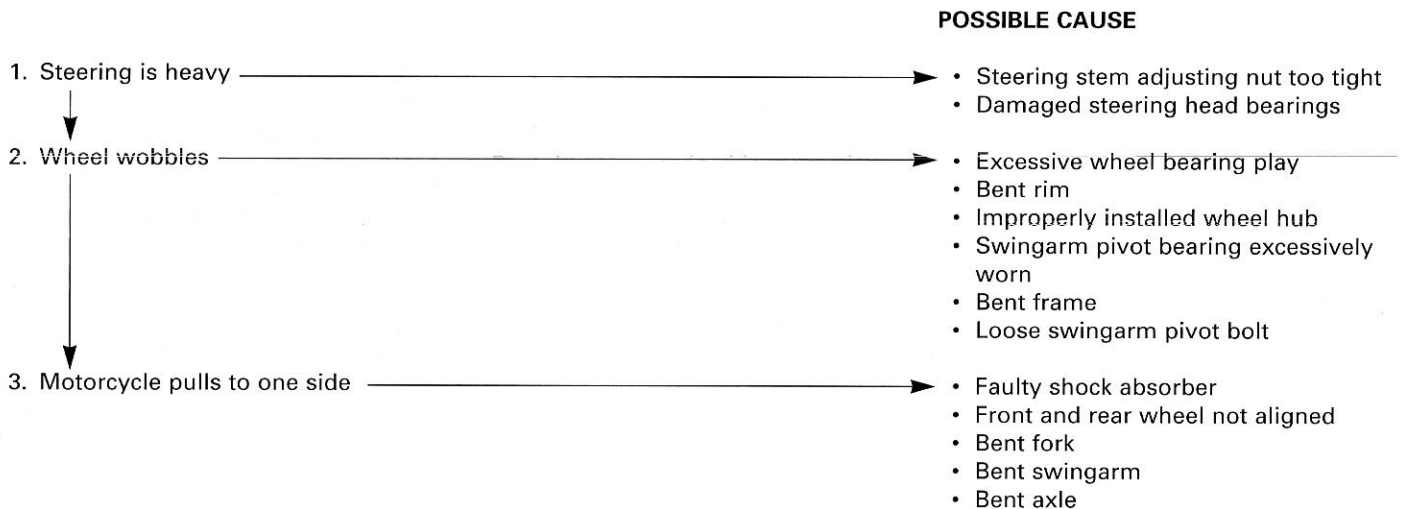

- For the following recommendations 4 through 10, to be most useful, the motorcycle must be adjusted as follows:  
Forks — compression damping at standard position, at standard fork oil quantity and viscosity, and air pressure zero.  
Shock — nitrogen pressure 142 psi, compression and rebound damping standard position, and spring preload adjusted so the bike sags with rider seated – see Owner’s Manual for spring preload adjustment.
- Make only one change at a time, then test ride and evaluate the difference before making further adjustments.  
The solutions are given in the preferred sequence of adjustment.

**POSSIBLE REMEDY**

4. Front end oversteers; it cuts too sharply (such as in sand):	→	<ul style="list-style-type: none"><li>• Increase the fork oil capacity</li><li>• Use stiffer fork spring</li></ul>
↓		
5. Front end understeers; it washes out or pushes	→	<ul style="list-style-type: none"><li>• Lower fork oil level</li><li>• Use softer fork spring</li></ul>
↓		
6. Front end hunts at high speed: it wanders under power:	→	<ul style="list-style-type: none"><li>• Slide forks down 5 mm in fork clamps</li><li>• Increase the fork oil capacity</li><li>• Increase shock preload</li></ul>
↓		
7. Front end shakes under heavy braking	→	<ul style="list-style-type: none"><li>• Decrease shock preload</li><li>• Increase shock rebound damping</li><li>• Increase the fork oil capacity</li></ul>
↓		
8. Front end hops over bumps in smooth turns:	→	<ul style="list-style-type: none"><li>• Change to lighter fork oil</li><li>• Decrease the fork oil capacity</li><li>• Decrease fork compression damping</li><li>• Use softer fork spring</li></ul>
↓		
9. Rear end hops over bumps while accelerating:	→	<ul style="list-style-type: none"><li>• Decrease shock preload</li><li>• Decrease shock compression damping</li></ul>
↓		
10. Rear end gets poor traction while accelerating away from a corner.	→	<ul style="list-style-type: none"><li>• Decrease shock preload</li><li>• Decrease shock compression damping</li></ul>

# 18. INDEX

Air Cleaner	3-5	Number Plate	2-3
Air Cleaner Housing	4-18	Nuts, Bolts, Fastener	3-19
Alternator	14-8	Optional Parts	1-21
Alternator coil	14-7	Radiator	5-5
Brake Fluid	3-13	Radiator Coolant	3-8
Brake Fluid Replacement/Air Bleeding	13-3	Radiator Shroud	2-3
Brake Pad/Disc	13-6	RC Valve	16-1
Brake Pad Wear	3-14	RC Valve Cable	8-9
Brake Pedal	13-21	Rear Brake Caliper	13-18
Brake System	3-14	Rear Master Cylinder	13-12
Cable & Harness Routing	1-17	Rear Wheel	12-4
Carburetor Adjustment, Major	4-4	Reed Valve	4-14
Carburetor Adjustment, Minor	4-3	Regulator/Rectifier	14-12
Carburetor Assembly/Installation	4-10	Right Crankcase Cover	9-3
Removal/Disassembly	4-7	Seat	2-2
Clutch	9-4	Service Information	
Clutch System	3-15	(Clutch/Kickstarter/Gearshift Linkage)	9-1
Control Cables	3-16	(Cooling System)	5-1
Coolant Replacement	5-4	(Crankcase/Crankshaft/Transmission)	10-1
Cooling System	3-8	(Cylinder Head/Cylinder/Piston)	7-1
Cooling System Testing	5-3	(Engine Removal/Installation)	6-1
Crankcase Bearing Replacement	10-9	(Frame/Body Panels/Exhaust System)	2-1
Crankcase Assembly	10-16	(Front Wheel/Suspension/Steering)	11-1
Separation	10-4	(Fuel System)	4-1
Crankshaft Installation	10-13	(Hydraulic Brake)	13-1
Removal	10-8	(Ignition System/Alternator)	14-1
Cylinder Head	7-3	(Maintenance)	3-1
Cylinder Head Decarbonizing	3-9	(RC Valve)	8-1
Cylinder, Piston	7-5	(Rear Wheel/Suspension)	12-1
Drive Chain	3-10	Service Rules	1-1
Drive Chain Rollers	3-12	Servo Motor	8-7
Drive Chain Sliders	3-12	Shock Absorber	12-10
Drive/Driven Sprocket	3-12	Shock Linkage	12-25
Engine Control Module (ECM)	14-6	Side Covers	2-2
Engine Installation	6-3	Spark Plug	3-7
Removal	6-2	Specifications	1-3
Engine Stop Switch	14-11	Steering Head Bearings	3-19
Exhaust Pipe	2-5	Steering Stem	11-33
Exhaust Valve	8-3	Sub-Frame	2-3
Exhaust Valve And Exhaust Valve Linkage		Suspension	3-17
Decarbonizing	3-9	Swingarm	12-30
Expansion Chamber/Silencer	3-16	Swingarm/Shock Linkage	3-18
Fork	11-9	Throttle Operation	3-5
Front Brake Caliper	13-15	Tools	1-13
Front Master Cylinder	13-9	Torque Values	1-10
Front Suspension	16-3	Transmission Assembly	10-14
Front Wheel	11-4	Disassembly	10-6
Fuel Tank	2-4	Transmission Oil	3-9
Gearshift Linkage	9-15	Troubleshooting, General	
Handlebar	11-27	- Engine Does Not Start Or Is Hard To Start	17-1
Ignition Coil	14-6	- Engine Lacks Power	17-2
Ignition Pulse Generator	14-8	- Poor Handling	17-4
Ignition System Inspection	14-4	- Poor Performance At High Speed	17-4
Ignition Timing	14-10	- Poor Performance At Low And Idle Speed	17-3
Kickstarter	9-12	Troubleshooting, Specific	
Lubrication & Seal Points	1-15	(Clutch/Kickstarter/Gearshift Linkage)	9-2
Maintenance Schedule	3-3	(Cooling System)	5-2
Model Identification	1-1	(Crankcase/Crankshaft/Transmission)	10-3

## INDEX

---

Troubleshooting, Specific (cont'd)	
(Cylinder Head/Cylinder/Piston)	7-2
(Frame/Body Panels/Exhaust System)	2-1
(Front Wheel/Suspension/Steering)	11-3
(Fuel System)	4-2
(Hydraulic Brake)	13-2
(Ignition System/Alternator)	14-2
(RC Valve)	8-2
(Rear Wheel/Suspension)	12-3
Tuning For Special Conditions	4-6
Water Pump	5-7
Wiring Diagram	15-1
Wheel/Tires	3-19



MADE FROM 50% RECYCLED PAPER  
MINIMUM 10% POST-CONSUMER CONTENT